

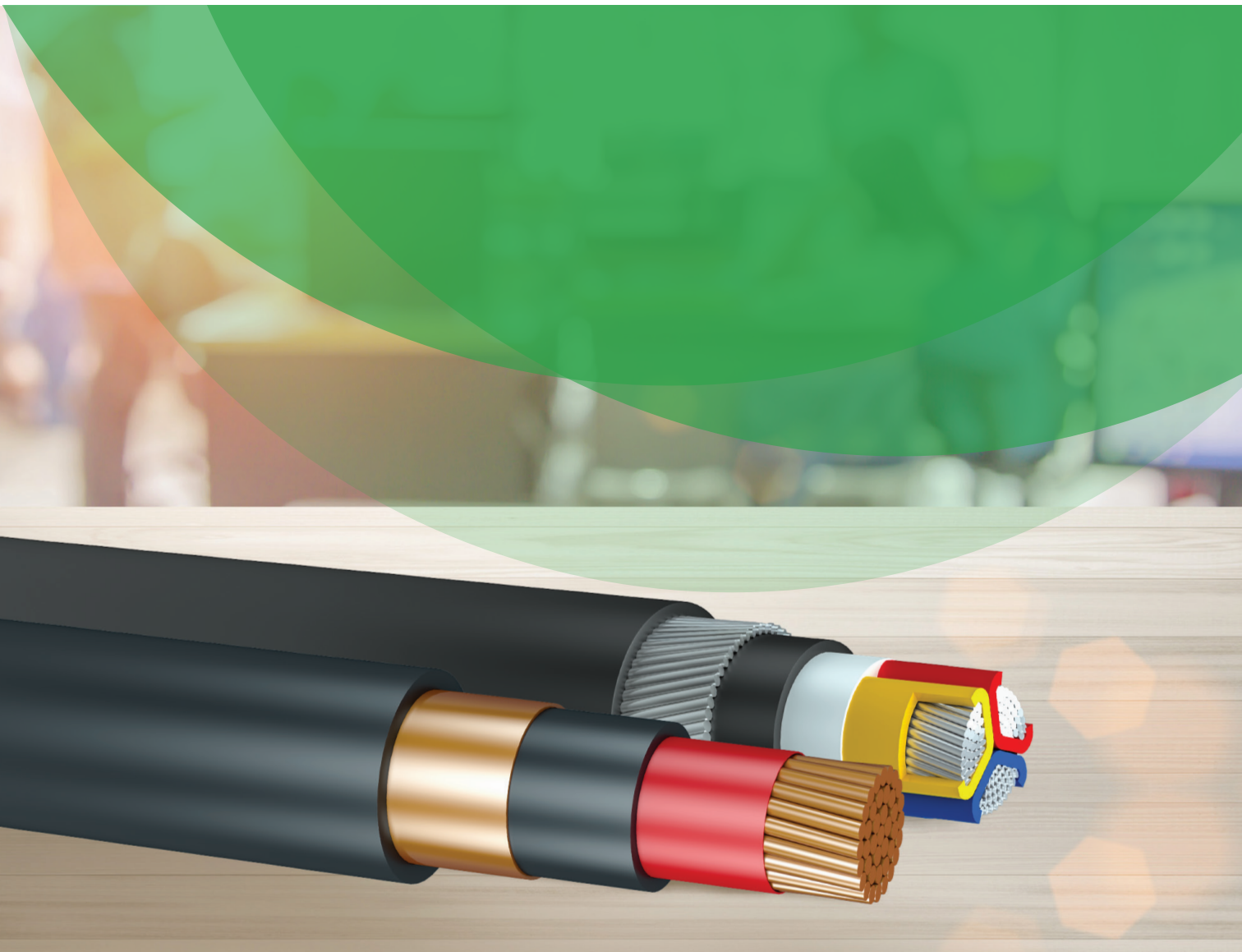

OmanCables
الكابلات العمانية

**BUILDING
SUSTAINABLE
GROWTH**

LOW VOLTAGE CABLES CATALOGUE





CONTENTS

Introduction.....	01
Technical Information & Cable Construction	03
LV Catalogue Technical Section Index	14
De-Rating & Group Rating Factors	139
Short Circuit Current Rating	150
Low Voltage Cables For Special Applications	158
Cable Laying And Installation Guidelines	162
Certificates	166

Oman Cables INDUSTRY

**DEDICATED TO
DELIVERING EXCELLENCE
IN THE CABLE
MANUFACTURING
INDUSTRY**

Oman Cables Industry manufacturing facilities are situated within the largest industrial complex in Muscat, Sultanate of Oman, with our offices and factory presently occupying an area of 135,000 sqm with future expansion plans in mind.

OCI have equivalent facilities in Sohar, Oman at its Aluminium manufacturing facility and together have a capacity of copper and aluminium of more than 120,000 MT annually.

MARKET SEGMENTS

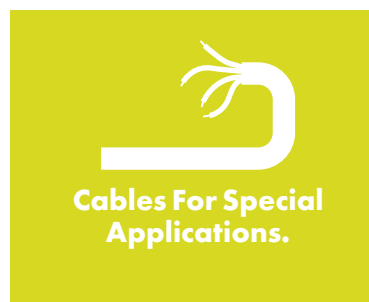

Oman Cables Industry (SAOG) has offices in Oman, UAE, Qatar, the KSA, and Egypt, as well as an extensive network of distributors and agents throughout the MENA, Asian, and European markets.

TECHNICAL INFORMATION & CABLE CONSTRUCTION

VOLTAGE DESIGNATION

Rated Voltage:

Rated voltage grade of the cables is designated as $U_0/U (U_m)$, where;

U_0 : Rated power frequency voltage between phase & earth or metallic screen for which the cable is suitable. (Also known as phase voltage or phase to neutral/earth).

U : Rated power frequency voltage between phase conductors for which cable is suitable. (Also known as line voltage or phase to phase voltage).

U_m : Maximum sustained power frequency voltage between phase conductors for which cable is suitable.

Rated voltage as per different specifications:

Insulation thickness & U_m as per IEC 60502-1 & BS 5467 are the same which means cables as per IEC 60502-1 can be used for cables as per BS 5467 and vice versa.

Voltage Grade as per IEC 60502-1	Voltage Grade as per 5467
0.6/1 (1.2) kV	0.6/1 (1.2) kV
1.8/3 (3.6) kV	1.9/3.3 (3.6) kV

System Category:

The rated voltage of the cable for a given application shall be suitable for the operating conditions in the system in which the cable is used. To facilitate the selection of the cable, systems are divided into three categories:

Category A: This category comprises those systems in which any phase conductor that comes in contact with earth or an earth conductor is disconnected from the system within 1 min.

Category B: This category comprises those systems which, under fault conditions, are operated for a short time with one phase earthed. This period, according to IEC 60183, should not exceed 1 h. For cables covered by IEC 60502-1/BS 5467, a longer period, not exceeding 8 h on any occasion, can be tolerated. The total duration of earth faults in any year should not exceed 125 h.

Category C: This category comprises all systems which do not fall into category A or B.

It should be realized that in a system where an earth fault is not automatically and promptly isolated, the extra stresses on the insulation of cables during the earth fault reduce the life of the cables to a certain degree. If the system is expected to be operated fairly often with a permanent earth fault, it may be advisable to classify the system in category C.

LOW VOLTAGE CABLES

Constructional Features:

Conductor: The conductor is the metallic part of the cable that carries the electric current. The better the material - the better the conductivity. Conductor materials are mainly:

- i) Copper
- ii) Aluminium

The conductor structure shall comply to the requirements of BS EN 60228 / IEC 60228.

Insulation: Each core conductor is insulated by extruded XLPE (cross-linked polyethylene) or extruded PVC (Polyvinyl Chloride). The insulating compound is a developed material suitable for application through extrusion process. The insulation thickness is selected based on the designated voltage grade complying with IEC 60502-1/ BS 5467 or any other International Standard.

Core Identification: Core identification is provided by coloured insulation or number printing. Depending upon the customer's project requirement, Oman Cables has the capability to provide any colour identification.

Cable cores are identified either by colour or by numbers as follows:
No. of cores Identification

	Old colour coding	New Colour coding as per BS
1	Red or Black	Brown or Blue
2	Red & Black	Brown & Blue
3	Red, Yellow & Blue	Brown, Black & Grey
4	Red, Yellow, Blue & Black	Blue, Brown, Black & Grey
5	Red, Yellow, Blue, Black & Y/G	Blue, Brown, Black, Grey & Y/G
6-61	By numbers	By numbers

Core Assembly: In case of multi-core cables, the insulated cores are laid up together with nonhygroscopic polypropylene (PP) filler followed by binder tape. PP Fillers are generally used to maintain cable circularity whereas binder tape is provided to hold the laid-up assembly together.

Bedding: The Extruded bedding material used is compatible with the operating temperature of insulation material. Thickness of bedding shall be as per IEC 60502 Part-1 or BS 5467 or any other International Standard. Extruded bedding layer serves as a bedding for armour wires. This helps to protect the laid-up core assembly from damage.

Armouring: Armouring provides mechanical protection against crushing forces. Armour also can serve as an Earth Continuity Conductor (ECC). The Armouring type could be:

- Wire armouring
- Double Tape armouring

Armouring material can be galvanized steel for multi-core cables and aluminium for single core cables.

Outer Sheath: This is the outer protection part of the cable, which protects against the surrounding environment. Depending upon the special properties & the application area, special additives are added to meet below properties:

- Anti-rodent & termite resistant property.
- UV resistant property.
- Oil resistant property.
- Flame retardant property

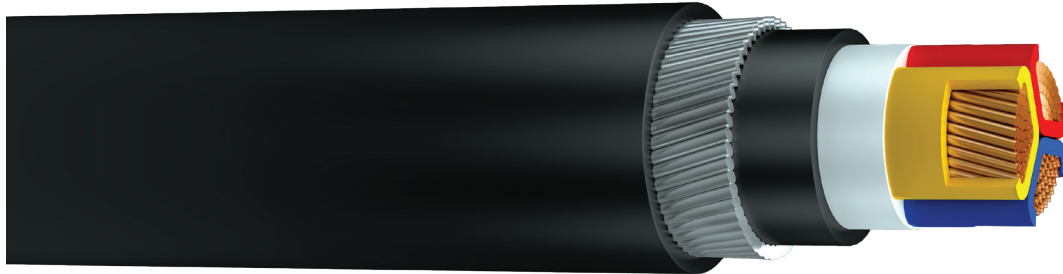

SPECIAL CHARACTERISTICS:

Oxygen Index: The criterion for burning is the presence of a percentage of oxygen in the air. By mixing oxygen and nitrogen at various percentages this test finds at what percentage of oxygen the standard specimen starts burning. The higher the oxygen index; the higher the resistance to ignition.

Temperature Index: Temperature index is the temperature at which the oxygen index of the material becomes 21. This test is carried out usually by extrapolation after the oxygen index is measured at various temperatures.

Smoke Density: This parameter relates to measuring and observing relative amounts of smoke produced by the burning or decomposition of materials. This test is carried out in accordance with ASTM D 2843. The measurements are made in terms of loss of light transmission through a collected volume of smoke produced under control standardized conditions.

Acid Gas Emission: During burning of cable materials acid gases are evolved especially hydrogen chloride. The gas emission is evaluated in accordance with test method IEC 60754-1, where approximately 1 gm. of the material is pyrolyzed at 800°C in a combustion tube and the resultant gases are analyzed.

Flame Retardance (IEC 60332-1): A single cable sample is clamped vertically. The flame is applied for a period of time depending upon the diameter of the cable. The test requirement is that after all burning has ceased the charred or affected portion shall not have reached within 50 mm from the top clamp.

Flame Retardance Test (IEC 60332 -3):

This test is carried out to check flame retardant properties of bunched cables. Three categories of tests namely category "A", "B" and "C" have been defined according to the quantity of combustible material available over unit length. Cable pieces are tied on a vertical ladder and the flame is applied from a horizontal ladder. After the specified time the burner is removed. All parameters are pre-defined according to specification. The charred portion is measured and compared with the standards to decide on acceptability.

SPECIAL MATERIAL PROPERTY	APPLICABLE TEST STANDARDS	DIFFERENT GRADES OF SHEATHING MATERIAL						
		PVC Type ST 2				ST 8	PE ST 7	
		FR	FRRT	FRLS	FROR	LSZH	PE	FRPE
Oxygen Index	ASTM D 2863	≥29	≥29	≥29	≥29	≥29	N/A	≥28
Temperature Index	ASTM D 2863	≥250°C	≥250°C	≥250°C	≥250°C	≥250°C	N/A	≥250°C
Smoke Density Rating	ASTM D 2843	N/A	N/A	≤ 60%	N/A	N/A	N/A	N/A
Light Transmission	IEC 61034-1 & 2	N/A	N/A	N/A	N/A	≤ 60%	N/A	≤ 60%
Acid Gas Generation	IEC 60754-1	N/A	≤ 17%	≤ 20%	N/A	≤ 0.5%	≤ 0.5%	≤ 0.5%
Flammability Test	IEC 60332-1	Yes	Yes	Yes	Yes	Yes	N/A	Yes
Flammability Test, CAT C	IEC 60332-3-24	Yes	Yes	Yes	Yes	Yes	N/A	Yes
Flammability Test, CAT A	IEC 60332-3-22	Yes	Yes	Yes	Yes	N/A	N/A	N/A
UV Resistance Property	ASTM G 155	Yes	Yes	Yes	Yes	Yes	Yes	Yes
Anti-Rodent & Termite Resistant Property	Choice & No-Choice External Test	Yes	Yes	Yes	Yes	Yes	N/A	N/A

Guidelines for Cable Selection based on the Installation conditions: Depending upon the location (Indoor or Outdoor):

Outdoor (Armoured Cables)	Indoor (Unarmoured Cables)
For Outdoor application Armoured Cables are recommended.	For Indoor application Unarmoured Cables are recommended.
For Outdoor application mechanical damages are expected to occur and armoured cables provide protection against this mechanical damage.	For Indoor application cables are not exposed to mechanical damages therefore protection is not required.
For Outdoor application, cables are typically stretched during installation. The armouring - mainly steel or aluminium - therefore aims to protect against this stretching.	For Indoor application cables are not being stretched during installation hence armouring is not required.
For Outdoor application armoured cables ensures electrical conductivity of the safety ground, which is achieved only through the metallic armour.	For Indoor application Unarmoured cables ensure electrical conductivity of the safety ground with the use of separate ground wire and need not to depend on the continuity of the conduit, hence armouring is not required.
For Outdoor application rodent or animals will chew the cables so that armour protect the cables from damage by animal or shoveling in direct bury application.	For Indoor application rodents or similar animals will not cause damage to cables, hence armouring is not required.
For Outdoor application where the cables are exposed to an RF environment that has an off-air RF signal powerful enough to interfere with the network, armouring - combined with grounding - provides another layer of RF protection.	For Indoor application cables are not exposed to RF environment, therefore armouring is not required to serve as another layer of RF protection.
For Outdoor application flexibility is not required. Therefore, armoured cables are being extensively used.	For Indoor application more flexibility is required. Therefore, Unarmoured cables are being extensively used in Unarmoured application.

Depending upon the installation location (PVC or LSZH sheathed cables):

PVC (Polyvinyl Chloride) Sheathed Cables	LSZH (Low Smoke Zero Halogen) Sheathed Cables
PVC sheathed cables are very soft, smooth and flexible.	LSZH sheathed cables are very Rough & Rigid since they contain Flame retardant compound.
PVC sheathed cables when burnt give off heavy black smoke, hydrochloric acid and other toxic gases.	LSZH sheathed cables when burnt do not emit toxic fumes and are free from halogenic materials (chlorine and fluorine).

PVC (Polyvinyl Chloride) Sheathed Cables	LSZH (Low Smoke Zero Halogen) Sheathed Cables
PVC sheathed cables are used commonly in buildings which feature contained ventilation systems running through the duct infrastructure.	LSZH sheathed cables are typically used in confined spaces where there are a large number of cables in close proximity to humans or sensitive electronic equipment - such as in submarines, ships, mass transit vehicles, central office facilities, and telecommunication applications.
PVC cables are used in applications such as computers and communication infrastructure, and in low voltage wiring.	LSZH sheathed cables are used where there are potential human health risks, or potential risks to sensitive and/or expensive electronic equipment.

Oman Cables Quality Assurance for LV Cables

In order to ensure the best quality products, it is essential to test and inspect the product at each stage of manufacturing including raw materials and finished product.

Oman Cables Quality Assurance System includes:

Raw Materials Inspection:

All the raw materials are sourced from internationally approved companies, known for their quality products. Once the material is received with their product certificate, Oman Cables quality team tests and inspects the same again. Only those materials which meet Oman Cables internal standards are released for production.

Finished Product Inspection:

Oman Cables products are fully tested to the applicable standard to which they are manufactured before leaving the factory.

LV Cables Testing Procedure:

1. Routine tests

Routine tests are normally carried out on each manufactured length of cable. The routine tests carried out in our manufacturing facilities are as follows:

- a) Measurement of the electrical resistance of conductors;
- b) Voltage test.

2. Sample tests

The sample tests carried out in our manufacturing facilities are as follows:

- a) Conductor examination.
- b) Check of dimensions.
- c) Hot set test for XLPE insulations.

3.Type tests

When type tests have been successfully performed on a type of cable covered by this catalogue with a specific conductor cross sectional area and rated voltage, type approval shall be accepted as valid for cables of the same type with other conductor cross-sectional areas and/or rated voltages, provided the following three conditions are all satisfied:

- The same insulation materials and manufacturing processes are used;
- The conductor cross-sectional area is not larger than that of the tested cable, with the exception that all cross-sectional areas up to and including 630mm² are approved when the cross-sectional area of the previously tested cable is in the range of 95mm² to 630mm² inclusive;
- The rated voltage is not higher than that of the tested cable.

Approval shall be independent of the conductor material.

Oman Cables' Advanced Testing Laboratory

Oman Cables' Advanced Testing Laboratory (ATL) is a one-of-a-kind laboratory equipped with modern cable testing equipment. ATL has the capability to perform comprehensive cable testing according to international standards. This includes regular tests like the complete cable type test, special tests like the accelerated ageing test, as well as flame retardancy, smoke density, toxic gas emission, fire tests, and many more as per various IEC & BS standards. The lab is fully dedicated to new product development and specialized cable testing. Some key highlights of the ATL are:

- The lab is capable of performing complete type tests, research and development, and the very specific Accelerated Ageing test for MV cables - which only a few labs in the GCC can perform.
- The lab is an independent building spanning over 1,500 m².
- ATL follows certifications of ISO 9001, ISO 14001, ISO 45001:2018 & BASEC Product Certification Requirements (PCR).

ATL Capabilities: How we do it?



Some of the testing equipment from Oman Cables' ATL lab are listed here:

- Accelerated Ageing & HV Breakdown test.

Fire and Smoke Testing Equipment's:

- Smoke density – 3m cube test chamber.
- Vertical flame propagation test chamber.
- Fire survival circuit integrity test BS-6387 'CW&Z'.
- Fire survival circuit integrity test F120 & PH120.
- Cone Calorimeter.
- Oxygen Index test apparatus.

Mechanical Testing:

- Tensile & Elongation.
- Hot set test for insulation.
- Hardness.

Microscopy

Electrical:

- Volume resistivity.
- Conductivity.

Weatherability:

- UV testing
- Moisture content testing

Halogen & fluorine content

Aging Capability

1.Oxygen Index Test:

The Limiting Oxygen Index Apparatus measures the minimum percentage of oxygen in the test atmosphere that is required to marginally support combustion as per ASTM D2863. The unit gives a continuous digital readout of oxygen concentrations in the test atmosphere to facilitate quick readouts of the test concentration. Characteristic features of this test apparatus are the digital display of oxygen percentage in the atmosphere during the test (with no calculations needed), and a digital display of the temperature of the gas mixture entering the test chimney.



2.Smoke Density _ 3m Cube Test:

The 3 Meter Cube is used for measuring smoke emission when electric cables are burned under defined conditions (IEC 61034). An example would be a few cables burned horizontally. These units are produced to meet the specification used in many electric cable tests.



3.Vertical Flame Propagation Test:

This test chamber is used for the assessment of vertical flame spread over vertically mounted bunched wires or cables - either electrical or optical - under defined conditions.



4.Halogen Gas Emission:

Halogens are a group of highly reactive chemically related elements, with the commonly encountered ones being fluorine, chlorine, bromine and iodine. Fluorine and chlorine are gases under normal conditions, bromine is a liquid and iodine is a solid. With a little heat, they all turn to gas. All halogens readily form acids, and this can happen when a halogen released as a gas by a fire comes into contact with water used to extinguish the fire. Much of the damage that occurs after a fire can be caused by these acids, as they will attack anything from the circuit boards in computers to the structural steel giving the building strength.

The halogen gases can also form acids when they come into contact with moist living surfaces such as eyes and lungs, causing serious injury.

Halogens are also good fire retardants, meaning that some of the options available for making a cable flame retardant can also mean that the cable will emit dangerous gases in a fire. Where this is not important it is quite easy to make a cable flame retardant by using halogenated materials.

600/1000 V LV UNARMoured POWER CABLES

SINGLE CORE COPPER CONDUCTOR, XLPE INSULATION, UNARMOURED & PVC SHEATH, LOW VOLTAGE POWER CABLE.

APPLICATION

For use indoors - in cable trenches or ducts; and outdoors - in power stations, industrial plants and switchgears if mechanical protection is not required, or in applications where the cable is not exposed to mechanical damage.

CONSTRUCTION

Multi-Stranded Annealed Plain Copper conductor, XLPE insulation and Overall Extruded PVC Outer Sheath.

1. Conductor

Annealed Plain Copper (Multi Stranded, Class-2)

2. Insulation

Extruded XLPE

3. Outer Sheath

Extruded Overall PVC Outer Sheath.

APPLICATION STANDARDS

Low Voltage Cables are designed and tested to meet the requirements of below standard:

- IEC 60502-1

Oman Cables can also supply a range of alternative designs to meet customer specified requirements.

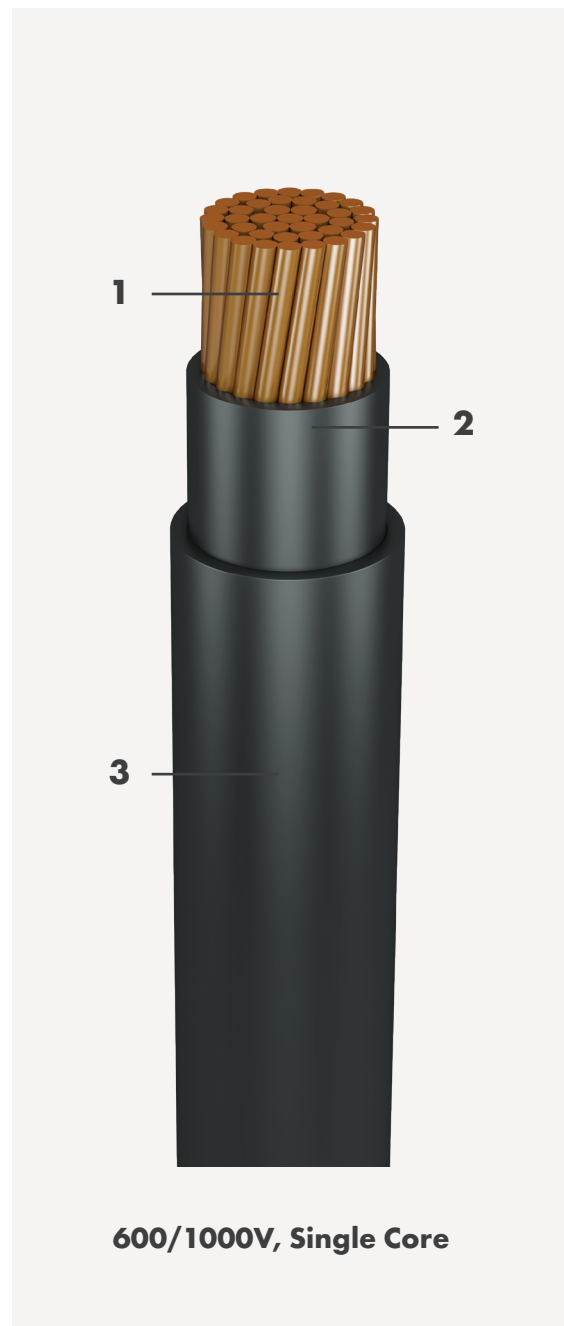

CORE COLOUR IDENTIFICATION

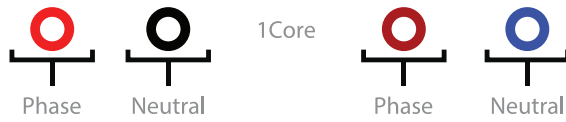

Note: Oman Cables has the capability to provide colour identification as per project requirements.

CHARACTERISTICS

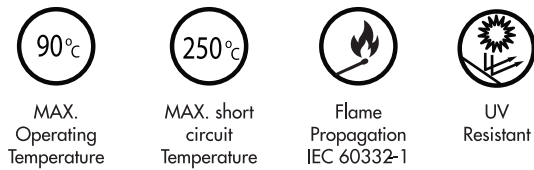

CABLE INSTALLATION

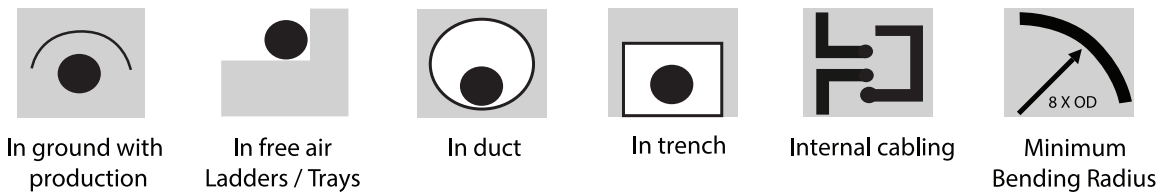

MULTI CORE COPPER CONDUCTOR, XLPE INSULATION, UNARMOURED & PVC SHEATH, LOW VOLTAGE POWER CABLE.

APPLICATION

For use indoors - in cable trenches or ducts; and outdoors - in power stations, industrial plants and switchgears if mechanical protection is not required, or in applications where the cable is not exposed to mechanical damage.

CONSTRUCTION

Stranded Annealed Plain Copper Conductor, XLPE insulation, Non-hygroscopic Fillers & Binder tape (as required) and Overall Extruded PVC Outer Sheath.

1. Conductor

Annealed Plain Copper (Multi Stranded, Class-2)

2. Insulation

XLPE

3. Fillers & Binder Tape

Non-hygroscopic Fillers & binder tape

4. Outer Sheath

Extruded Overall PVC Outer Sheath.

APPLICATION STANDARDS

Low Voltage Cables are designed and tested to meet the requirements of below standard:

- IEC 60502-1

Oman Cables can also supply a range of alternative designs to meet customer specified requirements.

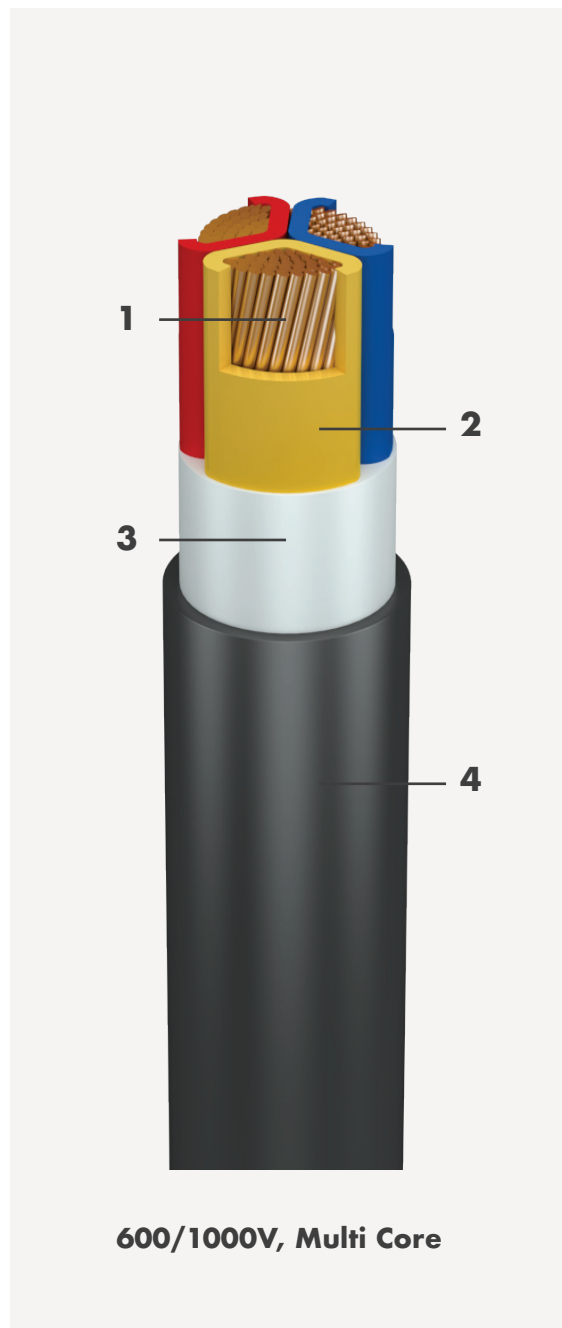

CORE COLOUR IDENTIFICATION



Note: Oman Cables has the capability to provide colour identification as per project requirements.

CHARACTERISTICS

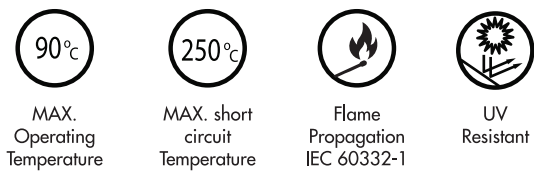

CABLE INSTALLATION

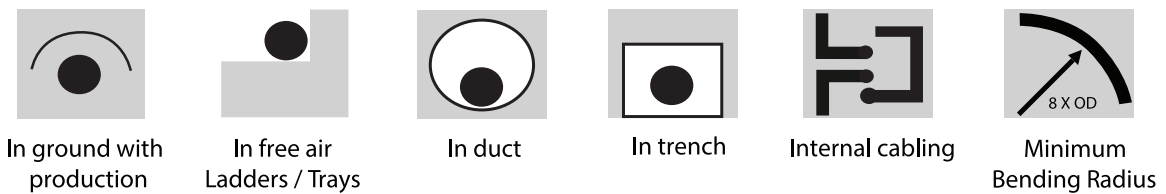

Cable size (mm ²)	Electrical Parameters										Current Rating *									
	DC Resistance (Max) (Ω/km)	AC Resistance at 90°C (Approx.) (Ω/km)	Reactance (Approx.) at 50Hz. (Ω/km)		Impedance (Approx.) at 50Hz. (Ω/km)		Voltage Drop (Approx.) (mV/A/m)			Ground at 35°C, (A)			Air at 50°C, (A)							
			1 C	Multi-core	1 C	Multi-core	1 C	2 C	3/4/5 C	1 C	2 C	3/4 C	5 C	1 C	2 C	3/4 C	5 C			
1.5	12.1	15.43	0.142	0.108	15.43	15.43	30.86	30.86	26.73	-	33	28	24	22	22	19	16.00			
2.5	7.41	9.45	0.132	0.101	9.45	9.45	18.9	18.9	16.37	-	42	36	30	30	30	27	22.00			
4	4.61	5.88	0.123	0.095	5.88	5.88	11.76	11.76	10.18	-	56	47	40	39	39	34	28.00			
6	3.08	3.93	0.114	0.09	3.93	3.93	7.86	7.86	6.81	-	70	59	50	49	50	44	36.00			
10	1.83	2.33	0.107	0.085	2.33	2.33	4.66	4.66	4.04	82	94	79	68	67	67	58	48.00			
16	1.15	1.47	0.1	0.082	1.47	1.47	2.94	2.94	2.55	108	121	102	87	92	97	83	70.00			
25	0.727	0.928	0.1	0.068	0.933	0.93	1.866	1.86	1.61	139	157	131	113	123	122	105	88.00			
35	0.524	0.669	0.096	0.068	0.676	0.672	1.352	1.344	1.16	165	188	157	135	146	151	129	109.00			
50	0.387	0.494	0.091	0.067	0.502	0.5	1.004	0.998	0.87	199	223	187	161	174	183	157	132.00			
70	0.268	0.343	0.086	0.062	0.354	0.35	0.708	0.698	0.61	244	273	229	197	222	232	200	167.00			
95	0.193	0.248	0.084	0.06	0.262	0.256	0.524	0.508	0.44	292	328	274	236	275	287	246	207.00			
120	0.153	0.197	0.082	0.06	0.213	0.207	0.426	0.41	0.36	332	372	312	268	321	335	288	241.00			
150	0.124	0.16	0.082	0.061	0.18	0.173	0.36	0.34	0.3	371	417	349	300	371	383	330	276.00			
185	0.0991	0.129	0.081	0.058	0.152	0.143	0.304	0.282	0.25	417	470	394	338	430	444	381	320.00			
240	0.0754	0.1	0.079	0.059	0.127	0.118	0.254	0.232	0.2	480	544	455	392	513	529	454	381.00			
300	0.0601	0.081	0.079	0.059	0.113	0.102	0.226	0.2	0.18	536	609	509	438	594	611	524	440.00			
400	0.047	0.065	0.077	0.056	0.101	0.089	0.202	0.174	0.15	594	687	574	495	692	711	608	512.00			
500	0.0366	0.053	0.077	0.056	0.093	0.08	0.186	0.154	0.14	658	758	633	-	801	784	671	-			
630	0.0283	0.044	0.075	0.055	0.087	0.074	0.174	0.142	0.13	723	843	705	-	925	873	746	-			
800	0.0221	0.037	0.075	-	0.084	-	0.168	-	-	764	-	-	-	1051	-	-	-			
1000	0.0176	0.032	0.074	-	0.081	-	0.162	-	-	810	-	-	-	1172	-	-	-			

Physical Dimensions														
Approx. Cable OD, mm				Approx. Cable Weight, kg/km					Standard Drum Length, m					
1 C	2 C	3 C	4 C	5 C	1 C	2 C	3 C	4 C	5 C	1 C	2 C	3 C	4 C	5 C
5.5	9.5	10	10.5	11.5	40	111	128	151	178	1000	1000	1000	1000	1000.00
6	10	11	11.5	12.5	51	141	166	199	238	1000	1000	1000	1000	1000.00
6.5	11	12	13	14	67	184	222	270	324	1000	1000	1000	1000	1000.00
7	12.5	13	14.5	15.5	88	241	296	362	439	1000	1000	1000	1000	1000.00
8	14	15	16.5	18.5	129	347	435	532	628	1000	1000	1000	1000	1000.00
8.5	16	17	18.5	20.5	186	456	611	775	912	1000	1000	1000	1000	1000.00
10.5	15.5	17.5	21	24.5	282	591	851	1119	1384	1000	1000	1000	1000	1000.00
11.5	17.5	20	23	27.5	373	781	1134	1488	1841	1000	1000	1000	1000	1000.00
12.5	20	23	25.5	31.5	492	1029	1497	1972	2292	1000	1000	1000	1000	500.00
14.5	22.5	26	30	36.5	686	1435	2110	2788	3813	1000	1000	1000	1000	500.00
16.5	25.5	29.5	33.5	41.5	940	1947	2861	3891	5286	1000	1000	1000	500	500.00
18	27.5	33	39	46	1174	2432	3794	5284	7327	1000	1000	500	500	500.00
20	31	37	43	51	1445	2502	3722	5242	7343	1000	500	500	500	500.00
22	33.5	39.5	48	57	1795	2859	4252	6066	8403	1000	500	500	500	500.00
24.5	40.5	46	53.5	64	2340	3431	5089	7067	10130	1000	500	500	500	250.00
27.5	44.5	51.5	59	71	2915	4032	5883	8248	11303	1000	500	500	500	250.00
30.5	49.5	56	67.5	80.5	3651	5084	7330	10111	14063	500	500	500	250	250.00
34.5	53.5	62	73	90	4366	6254	8677	11884	16336	500	500	250	250	250.00
38.5	60	69.5	82	-	5055	7382	10730	14292	-	500	500	250	250	-
43.5	-	-	-	-	3903	-	-	-	-	500	-	-	-	-
48	-	-	-	-	4872	-	-	-	-	500	-	-	-	-

Applicable standard: IEC 60502-1
 Flame retardant property: IEC 60332-3

*Depth of laying in ground 0.5 Mtr.
 Thermal resistivity of soil 1.2 K.m/W
 1 Core cables are considered with Trefoil touching.
 Un-armoured cables are not recommended for underground application.

SINGLE CORE ALUMINIUM CONDUCTOR, XLPE INSULATION, UNARMoured & PVC SHEATH, LOW VOLTAGE POWER CABLE.

APPLICATION

For use indoors - in cable trenches or ducts; and outdoors - in power stations, industrial plants and switchgears if mechanical protection is not required, or in applications where the cable is not exposed to mechanical damage.

CONSTRUCTION

Multi-Stranded Aluminium conductor, XLPE insulation and Overall Extruded PVC Outer Sheath.

1. Conductor

Aluminium (Multi Stranded, Class-2)

2. Insulation

Extruded XLPE

3. Outer Sheath

Extruded Overall PVC Outer Sheath.

APPLICATION STANDARDS

Low Voltage Cables are designed and tested to meet the requirements of below standard:

- IEC 60502-1

Oman Cables can also supply a range of alternative designs to meet customer specified requirements.

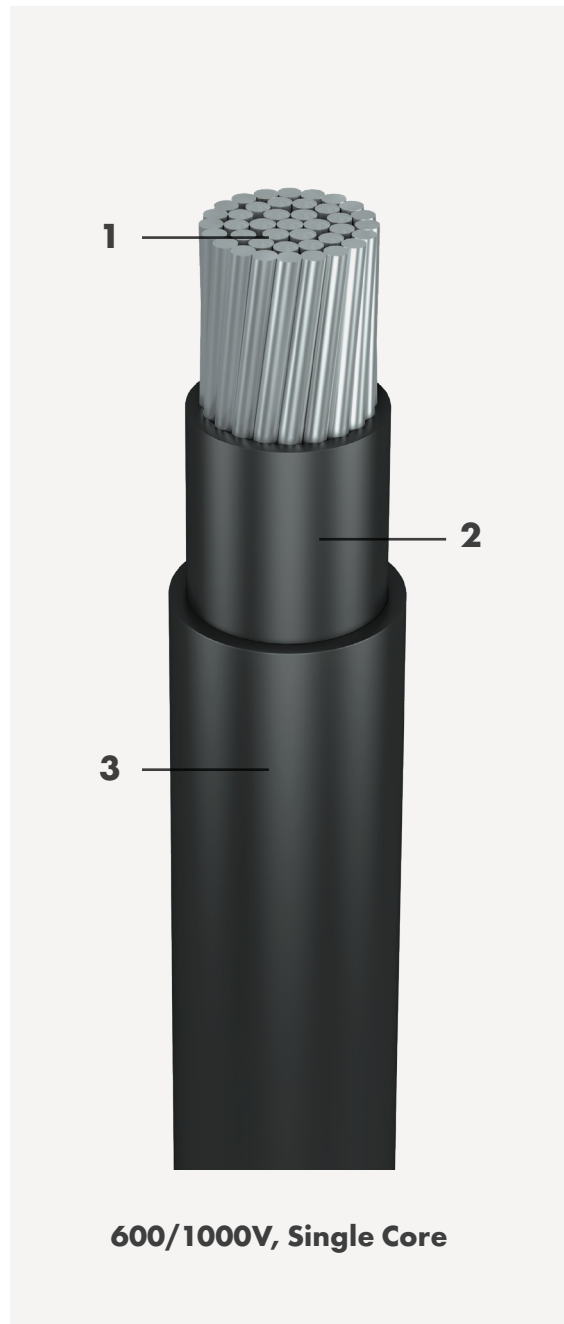

CORE COLOUR IDENTIFICATION

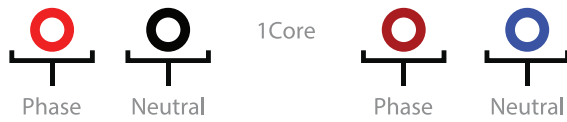

Note: Oman Cables has the capability to provide colour identification as per project requirements.

CHARACTERISTICS

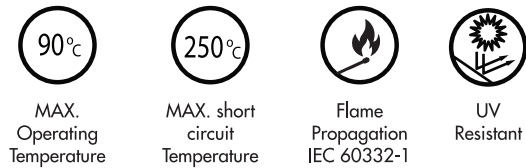

CABLE INSTALLATION

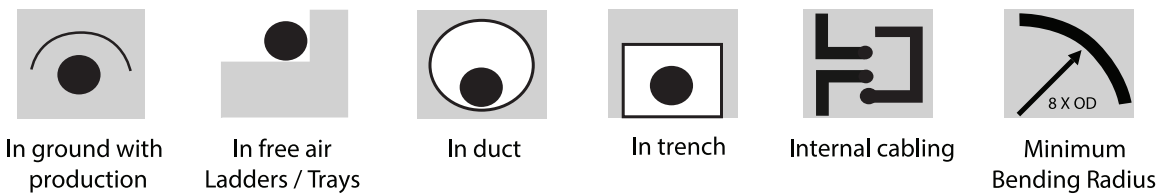

MULTI CORE ALUMINIUM CONDUCTOR, XLPE INSULATION, UNARMOURED & PVC SHEATH, LOW VOLTAGE POWER CABLE.

APPLICATION

For use indoors - in cable trenches or ducts; and outdoors - in power stations, industrial plants and switchgears if mechanical protection is not required, or in applications where the cable is not exposed to mechanical damage.

CONSTRUCTION

Stranded Aluminium Conductor, XLPE insulation, Non-hygroscopic Fillers & Binder tape (as required) and Overall Extruded PVC Outer Sheath.

1. Conductor

Aluminium (Multi Stranded, Class-2)

2. Insulation

XLPE

3. Fillers & Binder Tape

Non-hygroscopic Fillers & binder tape

4. Outer Sheath

Extruded Overall PVC Outer Sheath.

APPLICATION STANDARDS

Low Voltage Cables are designed and tested to meet the requirements of below standard:

- IEC 60502-1

Oman Cables can also supply a range of alternative designs to meet customer specified requirements.

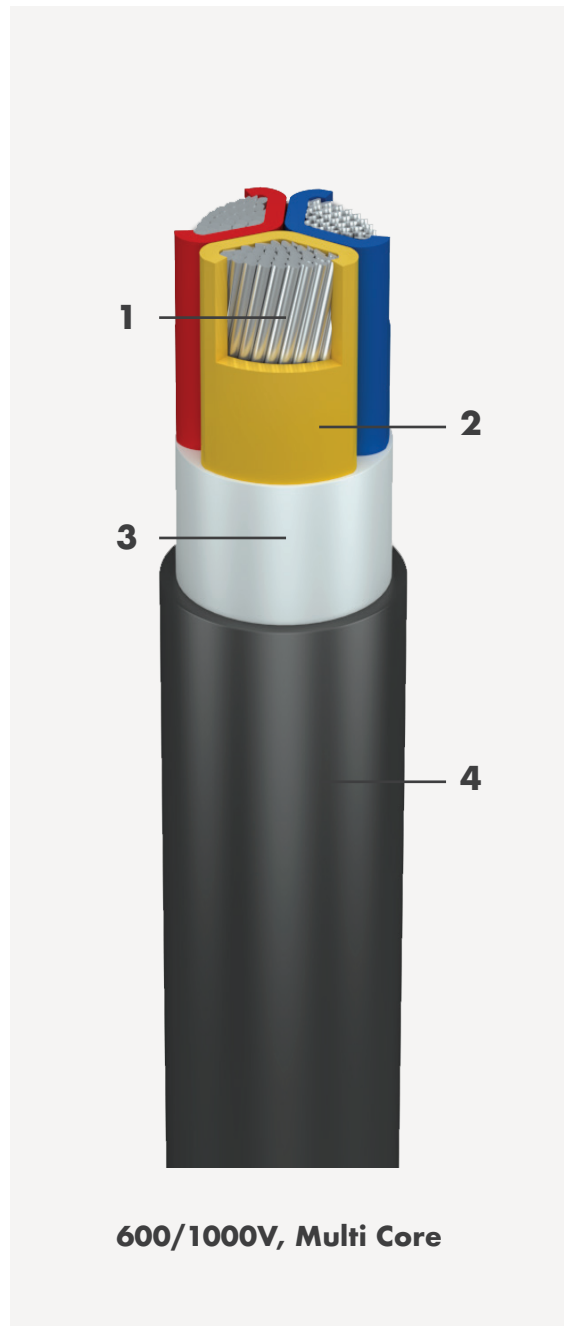

CORE COLOUR IDENTIFICATION



Note: Oman Cables has the capability to provide colour identification as per project requirements.

CHARACTERISTICS

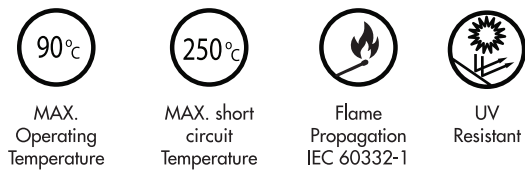

CABLE INSTALLATION

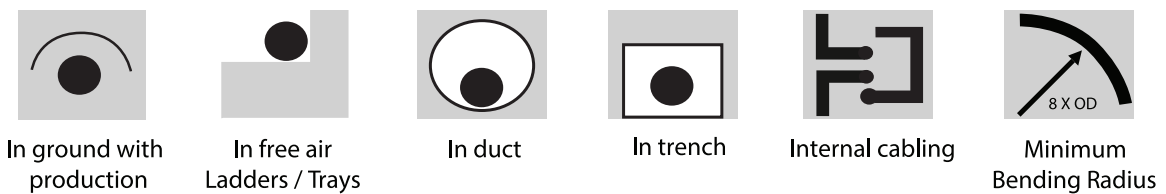

Cable size (mm ²)	Electrical Parameters								Current Rating *										
	DC Resistance (Ω /km)	AC Resistance (Ω /km)	Reactance (Approx.) at 50Hz. (Ω /km)		Impedance (Approx.) at 50Hz. (Ω /km)		Voltage Drop (Approx.) (mV/A/m)			Ground at 35°C, (A)				Air at 50°C, (A)					
			1 C	Multi-core	1 C	Multi-core	1 C	Multi-core	1 C	2 C	3/4/5 C	1 C	2 C	3/4 C	5 C	1 C	2 C	3/4 C	5 C
1.5	-	-	-	-	-	-	-	-	-	-	-	-	-	-	-	-	-	-	-
2.5	-	-	-	-	-	-	-	-	-	-	-	-	-	-	-	-	-	-	-
4	-	-	-	-	-	-	-	-	-	-	-	-	-	-	-	-	-	-	-
6	-	-	-	-	-	-	-	-	-	-	-	-	-	-	-	-	-	-	-
10	-	-	-	-	-	-	-	-	-	-	-	-	-	-	-	-	-	-	-
16	1.91	2.45	0.121	0.081	2.45	2.45	4.24	4.90	4.24	4.24	84	93	78	67	72	74	63	53	53
25	1.2	1.54	0.118	0.081	1.54	1.54	2.67	3.08	2.67	2.67	109	119	100	86	94	95	83	68	68
35	0.868	1.11	0.113	0.079	1.12	1.11	1.94	2.22	1.92	1.92	127	142	120	102	118	116	101	84	84
50	0.641	0.823	0.11	0.078	0.83	0.827	1.44	1.65	1.43	1.43	152	169	142	122	135	140	122	101	101
70	0.443	0.569	0.103	0.074	0.578	0.574	1	1.15	0.99	0.99	187	207	175	149	172	177	154	127	127
95	0.32	0.411	0.099	0.072	0.423	0.418	0.73	0.84	0.72	0.72	224	248	210	179	211	218	190	157	157
120	0.253	0.326	0.099	0.072	0.341	0.334	0.59	0.67	0.58	0.58	255	266	239	192	245	235	221	169	169
150	0.206	0.265	0.096	0.073	0.282	0.276	0.49	0.55	0.48	0.48	285	304	267	219	282	269	253	194	194
185	0.164	0.212	0.095	0.072	0.232	0.224	0.4	0.45	0.39	0.39	322	349	304	251	325	308	293	222	222
240	0.125	0.162	0.092	0.071	0.186	0.178	0.32	0.36	0.31	0.31	372	406	352	292	385	364	346	262	262
300	0.1	0.13	0.089	0.071	0.158	0.15	0.27	0.30	0.26	0.26	418	450	396	324	441	409	396	294	294
400	0.0778	0.102	0.089	0.07	0.135	0.125	0.23	0.25	0.22	0.22	481	492	428	354	526	470	420	338	338
500	0.0605	0.081	0.087	0.07	0.119	0.109	0.21	-	0.19	0.19	534	-	479	-	595	-	470	-	-
630	0.0469	0.064	0.085	0.07	0.106	0.096	0.18	-	0.17	0.17	589	-	536	-	672	-	526	-	-
800	0.0367	0.052	0.085	-	0.1	-	0.17	-	-	-	649	-	-	-	760	-	-	-	-
1000	0.0291	0.044	0.084	-	0.095	-	0.16	-	-	-	706	-	-	-	843	-	-	-	-

Physical Dimensions														
Approx. Cable OD, mm				Approx. Cable Weight, kg/km					Standard Drum Length, m					
1 C	2 C	3 C	4 C	5 C	1 C	2 C	3 C	4 C	5 C	1 C	2 C	3 C	4 C	5 C
-	-	-	-	-	-	-	-	-	-	-	-	-	-	-
-	-	-	-	-	-	-	-	-	-	-	-	-	-	-
-	-	-	-	-	-	-	-	-	-	-	-	-	-	-
-	-	-	-	-	-	-	-	-	-	-	-	-	-	-
-	-	-	-	-	-	-	-	-	-	-	-	-	-	-
8.5	16	17	18.5	20.5	95	265	325	395	435	1000	1000	1000	1000	1000
10.5	15.5	17.5	21	24.5	135	285	395	510	625	1000	1000	1000	1000	1000
11.5	17.5	20	23	27.5	165	360	500	640	785	1000	1000	1000	1000	1000
12.5	20	23	25.5	31.5	210	455	640	825	1165	1000	1000	1000	1000	500
14.5	22.5	26	30	36.5	285	605	865	1130	1590	1000	1000	1000	1000	500
16.5	25.5	29.5	33.5	41.5	370	800	1135	1480	2105	1000	1000	1000	500	500
18	27.5	33	39	46	455	975	1405	1855	2620	1000	1000	500	500	500
20	31	37	43	51	555	1195	1725	2260	3205	1000	500	500	500	500
22	33.5	39.5	48	57	685	1470	2130	2830	4015	1000	500	500	500	500
24.5	40.5	46	53.5	64	875	1915	2750	3635	5125	1000	500	500	500	250
27.5	44.5	51.5	59	71	1075	2340	3380	4450	6335	1000	500	500	500	250
30.5	49.5	56	67.5	80.5	1360	2945	4260	5640	8045	500	500	500	250	250
34.5	-	62	73	90	1705	-	5360	7075	-	500	-	250	250	-
38.5	-	69.5	82	-	2200	-	6880	9120	-	500	-	250	250	-
43.5	-	-	-	-	2765	-	-	-	-	500	-	-	-	-
48	-	-	-	-	3435	-	-	-	-	500	-	-	-	-

Applicable standard: IEC 60502-1
 Flame retardant property: IEC 60332-3

*Depth of laying in ground 0.5 Mtr.
 Thermal resistivity of soil 1.2 K.m/W
 1 Core cables are considered with Trefoil touching.
 Un-armoured cables are not recommended for underground application.

SINGLE CORE COPPER CONDUCTOR, PVC (TYPE A) INSULATION, UNARMOURED & PVC SHEATH, LOW VOLTAGE POWER CABLE.

APPLICATION

For use indoors - in cable trenches or ducts; and outdoors - in power stations, industrial plants and switchgears if mechanical protection is not required, or in applications where the cable is not exposed to mechanical damage.

CONSTRUCTION

Multi-Stranded Annealed Plain Copper conductor, PVC (TYPE A) insulation and Overall Extruded PVC Outer Sheath.

1. Conductor

Annealed Plain Copper (Multi Stranded, Class-2)

2. Insulation

Extruded PVC (TYPE A)

3. Outer Sheath

Extruded Overall PVC Outer Sheath.

APPLICATION STANDARDS

Low Voltage Cables are designed and tested to meet the requirements of below standard:

- IEC 60502-1

Oman Cables can also supply a range of alternative designs to meet customer specified requirements.

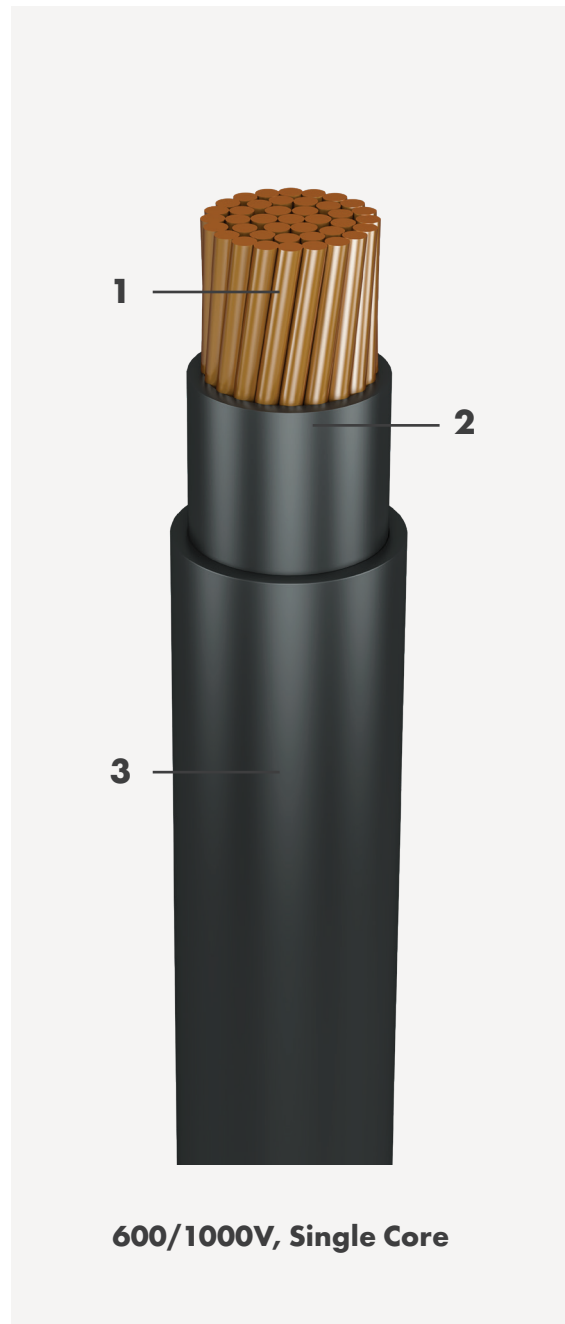

CORE COLOUR IDENTIFICATION

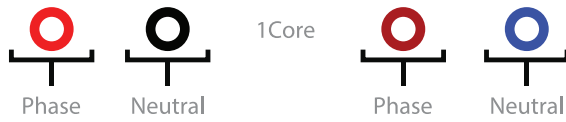

Note: Oman Cables has the capability to provide colour identification as per project requirements.

CHARACTERISTICS

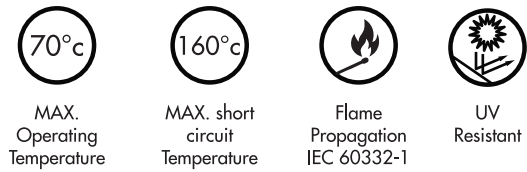

CABLE INSTALLATION

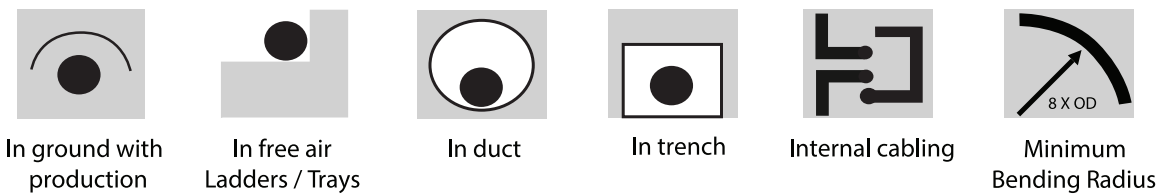

MULTI CORE COPPER CONDUCTOR, PVC (TYPE A) INSULATION, UNARMOURED & PVC SHEATH, LOW VOLTAGE POWER CABLE.

APPLICATION

For use indoors - in cable trenches or ducts; and outdoors - in power stations, industrial plants and switchgears if mechanical protection is not required, or in applications where the cable is not exposed to mechanical damage.

CONSTRUCTION

Stranded Annealed Plain Copper Conductor, PVC (TYPE A) insulation, Non-hygroscopic Fillers & Binder tape (as required) and Overall Extruded PVC Outer Sheath.

1. Conductor

Annealed Plain Copper (Multi Stranded, Class-2)

2. Insulation

Extruded PVC (TYPE A)

3. Fillers & Binder Tape

Non-hygroscopic Fillers & binder tape

4. Outer Sheath

Extruded Overall PVC Outer Sheath.

APPLICATION STANDARDS

Low Voltage Cables are designed and tested to meet the requirements of below standard:

- IEC 60502-1

Oman Cables can also supply a range of alternative designs to meet customer specified requirements.

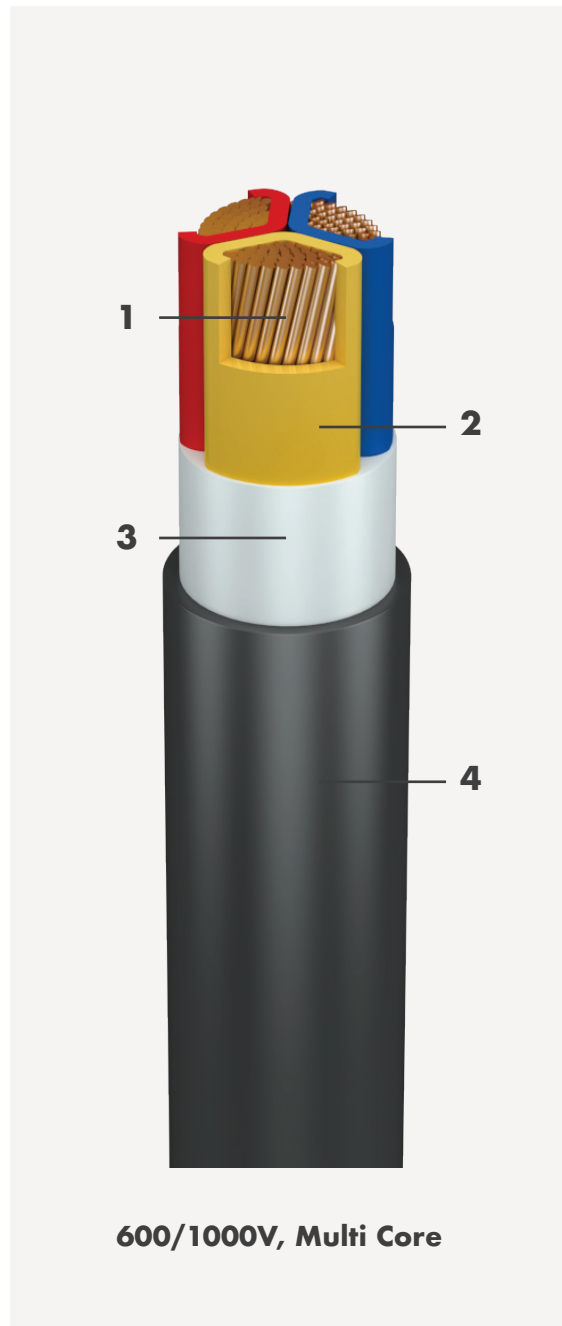

CORE COLOUR IDENTIFICATION

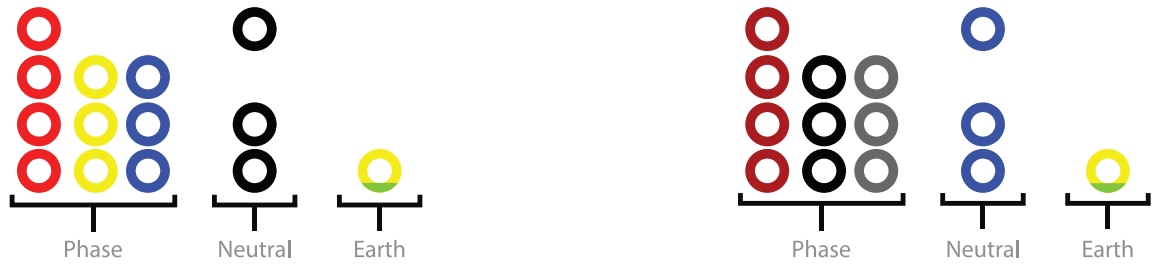

Note: Oman Cables has the capability to provide colour identification as per project requirements.

CHARACTERISTICS

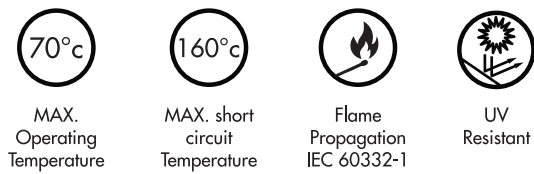

CABLE INSTALLATION

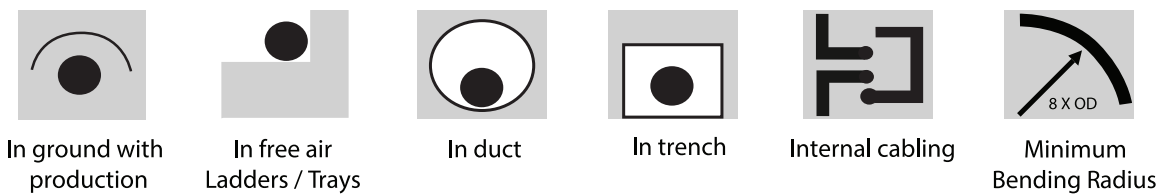

Cable size (mm ²)	Electrical Parameters						Current Rating *														
	DC Resistance (Ω/km)	AC Resistance (Ω/km)	Reactance (Approx.) at 50Hz. (Ω/km)		Impedance (Approx.) at 50Hz. (Ω/km)		Voltage Drop (Approx.) (mV/A/m)			Ground at 35°C, (A)				Duct at 35°C, (A)				Air at 50°C, (A)			
			1 C	Multi-core	1 C	Multi-core	1 C	2 C	3/4/5 C	1 C	2 C	3/4 C	5 C	1 C	2 C	3/4 C	5 C	1 C	2 C	3/4 C	5 C
1.5	12.1	14.48	0.147	0.11	14.48	14.48	25.080	28.96	25.08	-	26	22	19	-	21	18	15	16	16	14	12
2.5	7.41	8.87	0.137	0.103	8.87	8.87	15.363	17.74	15.36	-	33	28	24	-	27	23	19	22	22	20	16
4	4.61	5.52	0.132	0.102	5.52	5.52	9.561	11.04	9.56	-	44	38	32	-	36	30	26	29	29	25	21
6	3.08	3.69	0.123	0.097	3.69	3.69	6.391	7.38	6.39	-	55	47	40	-	46	38	33	36	37	32	27
10	1.83	2.19	0.114	0.091	2.19	2.19	3.793	4.38	3.79	68	74	62	53	64	61	51	44	49	48	42	35
16	1.15	1.38	0.11	0.087	1.38	1.38	2.390	2.76	2.39	89	95	81	68	84	78	66	56	67	65	56	47
25	0.727	0.871	0.106	0.085	0.877	0.875	1.519	1.75	1.52	115	126	106	91	111	103	86	74	90	87	74	63
35	0.524	0.628	0.101	0.083	0.636	0.633	1.102	1.27	1.10	136	152	127	109	127	123	103	89	107	107	91	77
50	0.387	0.464	0.098	0.083	0.474	0.471	0.821	0.94	0.82	162	180	150	130	159	146	122	105	123	130	111	94
70	0.268	0.322	0.09	0.077	0.334	0.331	0.579	0.66	0.57	198	222	186	160	193	180	152	130	156	163	141	117
95	0.193	0.232	0.09	0.077	0.249	0.245	0.431	0.49	0.42	238	266	223	192	226	217	182	156	194	202	174	145
120	0.153	0.185	0.087	0.075	0.204	0.2	0.353	0.40	0.35	270	302	254	217	249	247	208	178	226	235	202	169
150	0.124	0.15	0.087	0.075	0.173	0.169	0.300	0.34	0.29	301	338	284	243	274	277	234	199	260	269	231	194
185	0.0991	0.121	0.085	0.074	0.148	0.143	0.256	0.29	0.25	338	382	321	275	300	314	265	226	302	311	267	224
240	0.0754	0.093	0.084	0.074	0.125	0.12	0.217	0.24	0.21	388	441	370	318	335	364	306	262	360	370	318	266
300	0.0601	0.076	0.082	0.074	0.112	0.107	0.194	0.21	0.19	434	493	414	355	367	408	342	294	415	426	365	307
400	0.047	0.061	0.081	0.073	0.101	0.096	0.175	0.19	0.17	480	554	464	399	391	459	392	330	484	495	423	356
500	0.0366	0.05	0.08	0.072	0.094	0.088	0.163	0.18	0.15	528	611	512	-	418	506	432	-	557	546	466	-
630	0.0283	0.041	0.078	0.071	0.088	0.083	0.152	0.17	0.14	577	665	557	-	450	551	471	-	641	594	508	-
800	0.0221	0.035	0.076	-	0.084	-	0.145	-	-	605	-	-	-	470	-	-	-	726	-	-	-
1000	0.0176	0.031	0.076	-	0.082	-	0.142	-	-	638	-	-	-	497	-	-	-	808	-	-	-

Physical Dimensions																				
Approx. Cable OD, mm					Approx. Cable Weight, kg/km					Standard Drum Length, m										
1 C	2 C	3 C	4 C	5 C	1 C	2 C	3 C	4 C	5 C	1 C	2 C	3 C	4 C	5 C	1 C	2 C	3 C	4 C	5 C	
5.5	10.0	10.5	11	12	50	130	150	175	210	1000	1000	1000	1000	1000	1000	1000	1000	1000	1000	1000
6.0	10.5	11.0	12	13	60	160	190	230	275	1000	1000	1000	1000	1000	1000	1000	1000	1000	1000	1000
7.0	12.5	13.0	14.5	15.5	85	225	275	330	400	1000	1000	1000	1000	1000	1000	1000	1000	1000	1000	1000
7.5	13.5	14.5	16	17.5	105	290	355	430	520	1000	1000	1000	1000	1000	1000	1000	1000	1000	1000	1000
8.5	15.5	16.5	18	20	150	400	500	600	715	1000	1000	1000	1000	1000	1000	1000	1000	1000	1000	1000
9.5	17.0	18.5	20	22	210	500	670	855	1005	1000	1000	1000	1000	1000	1000	1000	1000	1000	1000	1000
11.0	16.5	19.0	22.5	26.5	310	650	935	1230	1515	1000	1000	1000	1000	1000	1000	1000	1000	1000	1000	1000
12.0	18.5	21.5	24.5	29	405	850	1230	1615	1995	1000	1000	1000	1000	1000	1000	1000	1000	1000	1000	1000
13.5	21.5	24.5	27.5	34	535	1125	1630	2150	2800	1000	1000	1000	1000	1000	1000	1000	1000	1000	1000	500
15.0	24.0	27.5	31.5	38.5	730	1540	2260	2985	3855	1000	1000	1000	1000	1000	1000	1000	1000	1000	500	500
17.5	27.5	31.5	36	44.5	1005	2095	3085	4075	5310	1000	1000	1000	1000	1000	1000	1000	1000	1000	500	500
19.0	29.5	35.0	41	48.5	1240	2580	3815	5065	6600	1000	1000	1000	1000	1000	1000	1000	1000	1000	500	500
21.0	32.5	38.5	45	53.5	1525	3180	4700	6240	8095	1000	1000	1000	1000	1000	1000	1000	1000	1000	500	500
23.0	35.0	41.5	50	59.5	1895	3940	5825	7755	10090	1000	1000	1000	1000	1000	1000	1000	1000	1000	500	500
26.0	42.5	48.0	56	67	2470	5150	7590	10080	13140	1000	1000	1000	1000	1000	1000	1000	1000	1000	500	250
28.5	47.0	54.0	62	74.5	3075	6400	9480	12570	16385	1000	1000	1000	1000	1000	1000	1000	1000	1000	250	250
32.0	52.5	58.5	70	84	3890	8165	12045	16045	20775	500	500	500	500	500	500	500	500	500	250	250
35.5	56.0	64.5	76	-	4955	10390	15410	20465	-	500	500	500	500	500	500	500	500	500	250	-
39.5	62.0	71.5	84	-	6320	13225	19630	26110	-	500	500	500	500	500	500	500	500	500	250	-
44.0	-	-	-	-	8015	-	-	-	-	500	-	-	-	-	-	-	-	-	-	-
48.5	-	-	-	-	10005	-	-	-	-	500	-	-	-	-	-	-	-	-	-	-

Applicable standard: IEC 60502-1
 Flame retardant property: IEC 60332-3

*Depth of laying in ground 0.5 Mtr.
 Thermal resistivity of soil 1.2 K.m/W
 1 Core cables are considered with Trefoil touching.
 Un-armoured cables are not recommended for underground application.

SINGLE CORE ALUMINIUM CONDUCTOR, PVC (TYPE A) INSULATION, UNARMOURED & PVC SHEATH, LOW VOLTAGE POWER CABLE.

APPLICATION

For use indoors - in cable trenches or ducts; and outdoors - in power stations, industrial plants and switchgears if mechanical protection is not required, or in applications where the cable is not exposed to mechanical damage.

CONSTRUCTION

Multi-Stranded Aluminium conductor, PVC (TYPE A) insulation and Overall Extruded PVC Outer Sheath.

1. Conductor

Aluminium (Multi Stranded, Class-2)

2. Insulation

Extruded PVC (TYPE A)

3. Outer Sheath

Extruded Overall PVC Outer Sheath.

APPLICATION STANDARDS

Low Voltage Cables are designed and tested to meet the requirements of below standard:

- IEC 60502-1

Oman Cable can also supply a range of alternative designs to meet customer specified requirements.

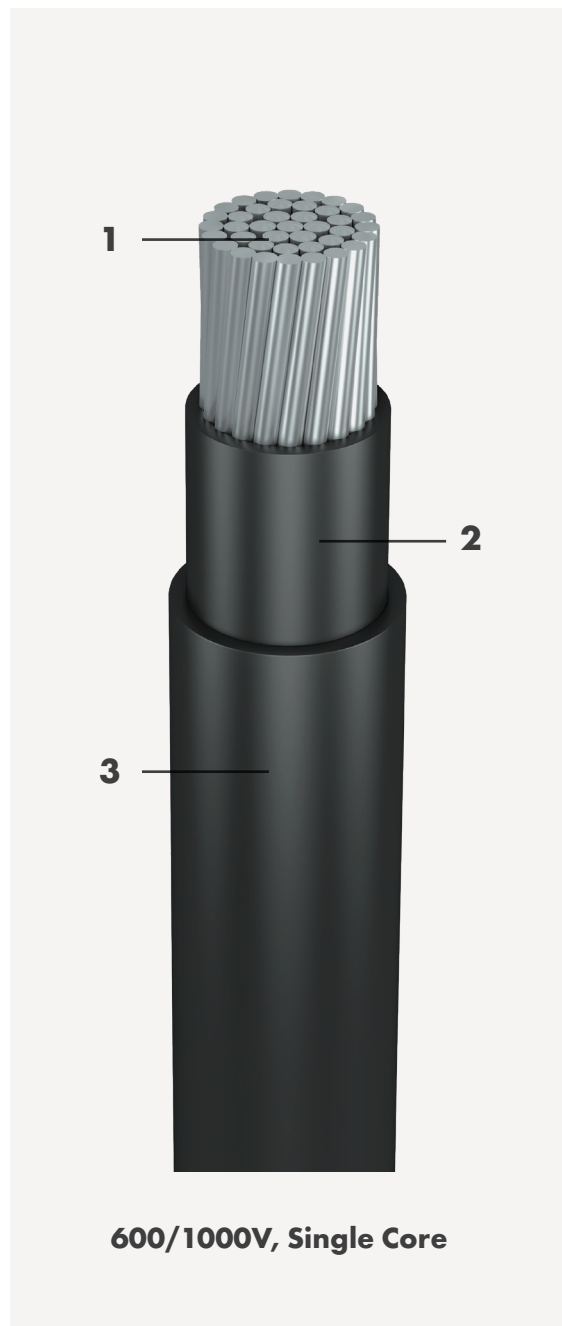

CORE COLOUR IDENTIFICATION

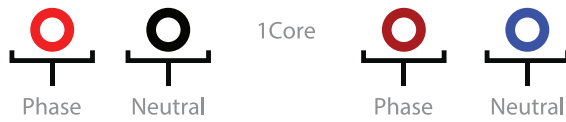

Note: Oman Cables has the capability to provide colour identification as per project requirements.

CHARACTERISTICS

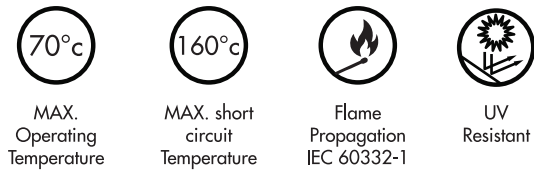

CABLE INSTALLATION

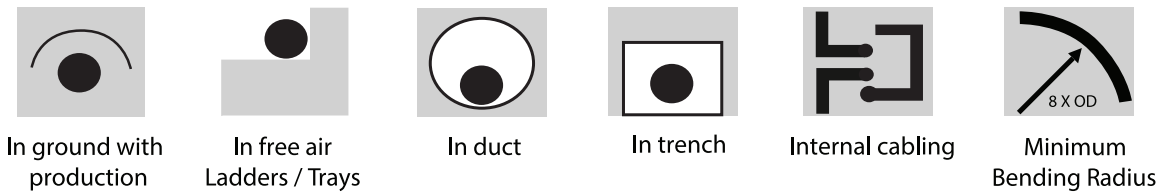

MULTI CORE ALUMINIUM CONDUCTOR, PVC (TYPE A) INSULATION, UNARMOURED & PVC SHEATH, LOW VOLTAGE POWER CABLE.

APPLICATION

For use indoors - in cable trenches or ducts; and outdoors - in power stations, industrial plants and switchgears if mechanical protection is not required, or in applications where the cable is not exposed to mechanical damage.

CONSTRUCTION

Stranded Aluminium Conductor, PVC (TYPE A) insulation, Non-hygroscopic Fillers & Binder tape (as required) and Overall Extruded PVC Outer Sheath.

1. Conductor

Aluminium (Multi Stranded, Class-2)

2. Insulation

Extruded PVC (TYPE A)

3. Fillers & Binder Tape

Non-hygroscopic Fillers & binder tape

4. Outer Sheath

Extruded Overall PVC Outer Sheath.

APPLICATION STANDARDS

Low Voltage Cables are designed and tested to meet the requirements of below standard:

- IEC 60502-1

Oman Cables can also supply a range of alternative designs to meet customer specified requirements.

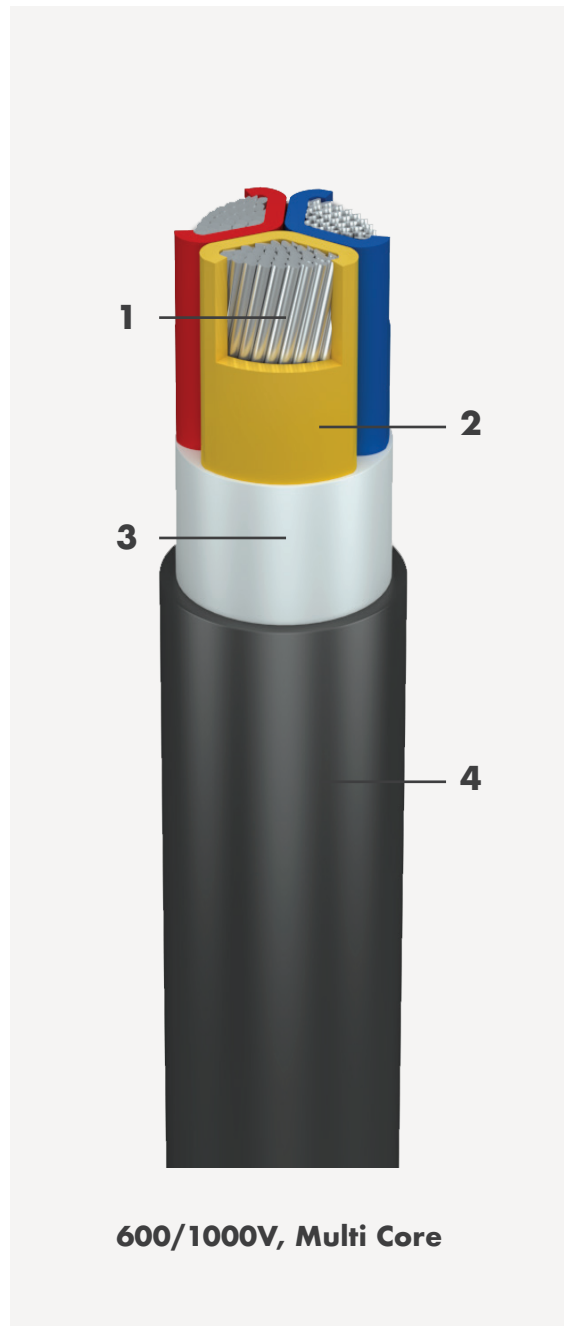

600/1000V, Multi Core

CORE COLOUR IDENTIFICATION



Note: Oman Cables has the capability to provide colour identification as per project requirements.

CHARACTERISTICS

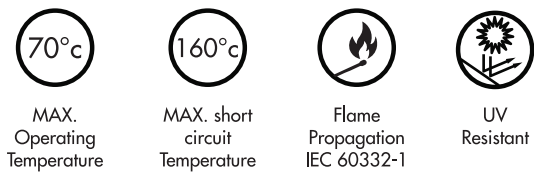

CABLE INSTALLATION

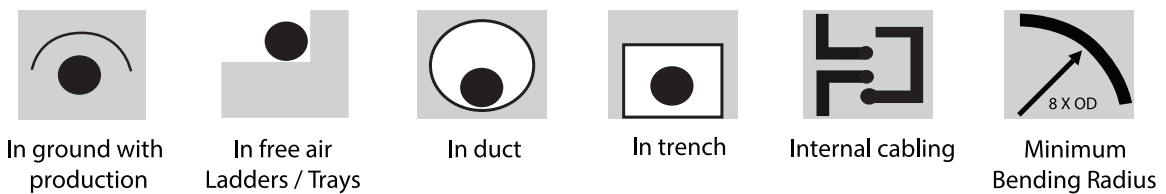

Cable size		Electrical Parameters						Current Rating *													
		DC Resistance (Ω/km)	AC Resistance (Ω/km)	Reactance (Approx.) (Ω/km)	Impedance (Approx.) (Ω/km)	Voltage Drop (Approx.) (mV/A/m)			Ground at 35°C, (A)			Duct at 35°C, (A)			Air at 50°C, (A)						
(mm ²)		1 C	Multi-core	1 C	Multi-core	1 C	2 C	3/4/5 C	1 C	2 C	3/4 C	5 C	1 C	2 C	3/4 C	5 C	1 C	2 C	3/4 C	5 C	
1.5	-	-	-	-	-	-	-	-	-	-	-	-	-	-	-	-	-	-	-	-	-
2.5	-	-	-	-	-	-	-	-	-	-	-	-	-	-	-	-	-	-	-	-	-
4	-	-	-	-	-	-	-	-	-	-	-	-	-	-	-	-	-	-	-	-	-
6	-	-	-	-	-	-	-	-	-	-	-	-	-	-	-	-	-	-	-	-	-
10	-	-	-	-	-	-	-	-	-	-	-	-	-	-	-	-	-	-	-	-	-
16	1.91	2.3	0.107	0.088	2.3	2.3	3.984	4.6	3.984	69	73	62	53	65	60	50	43	52	50	42	36
25	1.2	1.44	0.103	0.067	1.44	1.44	2.494	2.88	2.494	90	94	80	68	85	77	65	55	69	64	56	46
35	0.868	1.04	0.098	0.066	1.04	1.04	1.801	2.08	1.801	105	114	96	82	102	92	78	66	86	78	68	56
50	0.641	0.771	0.096	0.066	0.777	0.774	1.346	1.548	1.341	123	134	114	96	123	110	93	79	92	96	83	69
70	0.443	0.533	0.088	0.059	0.54	0.537	0.935	1.074	0.932	150	167	141	120	150	136	115	98	117	121	106	87
95	0.32	0.386	0.088	0.058	0.396	0.39	0.686	0.78	0.677	181	200	170	144	178	163	139	117	144	149	131	107
120	0.253	0.305	0.085	0.055	0.317	0.311	0.549	0.622	0.542	206	219	194	158	202	191	159	138	168	172	151	124
150	0.206	0.249	0.085	0.056	0.263	0.256	0.456	0.512	0.447	230	251	218	181	224	211	178	152	193	197	174	142
185	0.164	0.199	0.083	0.053	0.216	0.208	0.374	0.416	0.362	261	287	247	207	245	242	203	174	224	226	200	163
240	0.125	0.152	0.083	0.057	0.173	0.164	0.300	0.328	0.288	302	334	288	240	278	277	238	199	268	267	239	192
300	0.1	0.123	0.081	0.056	0.147	0.137	0.255	0.274	0.241	339	371	326	267	307	307	270	221	311	299	276	215
400	0.0778	0.097	0.08	0.055	0.126	0.114	0.218	0.228	0.199	389	402	353	289	335	351	295	253	375	344	308	248
500	0.0605	0.077	0.079	-	0.11	-	0.191	-	-	433	-	-	-	364	-	-	-	431	-	-	-
630	0.0469	0.062	0.077	-	0.099	-	0.171	-	-	479	-	-	-	394	-	-	-	496	-	-	-
800	0.0367	0.051	0.076	-	0.092	-	0.159	-	-	530	-	-	-	424	-	-	-	579	-	-	-
1000	0.0291	0.043	0.075	-	0.086	-	0.149	-	-	568	-	-	-	445	-	-	-	663	-	-	-

Physical Dimensions														
Approx. Cable OD, mm				Approx. Cable Weight, kg/km					Standard Drum Length, m					
1 C	2 C	3 C	4 C	5 C	1 C	2 C	3 C	4 C	5 C	1 C	2 C	3 C	4 C	5 C
-	-	-	-	-	-	-	-	-	-	-	-	-	-	-
-	-	-	-	-	-	-	-	-	-	-	-	-	-	-
-	-	-	-	-	-	-	-	-	-	-	-	-	-	-
-	-	-	-	-	-	-	-	-	-	-	-	-	-	-
-	-	-	-	-	-	-	-	-	-	-	-	-	-	-
9.5	17.0	18.5	20	22	115	310	385	470	525	1000	1000	1000	1000	1000
11.0	16.5	19.0	22.5	26.5	160	345	480	620	755	1000	1000	1000	1000	1000
12.0	18.5	21.5	24.5	29	195	425	590	760	940	1000	1000	1000	1000	1000
13.5	21.5	24.5	27.5	34	250	550	770	1000	1380	1000	1000	1000	1000	500
15.0	24.0	27.5	31.5	38.5	325	710	1015	1325	1820	1000	1000	1000	500	500
17.5	27.5	31.5	36	44.5	435	940	1355	1770	2440	1000	1000	500	500	500
19.0	29.5	35.0	41	48.5	520	1120	1630	2150	2965	1000	1000	500	500	500
21.0	32.5	38.5	45	53.5	635	1365	1980	2610	3615	1000	500	500	500	500
23.0	35.0	41.5	50	59.5	785	1685	2450	3250	4495	1000	500	500	500	500
26.0	42.5	48.0	56	67	1000	2195	3165	4175	5745	1000	500	500	500	250
28.5	47.0	54.0	62	74.5	1230	2675	3895	5125	7110	1000	500	500	250	250
32.0	52.5	58.5	70	84	1545	3360	4840	6435	8965	500	500	500	250	250
35.5	-	-	-	-	1920	-	-	-	-	500	-	-	-	-
39.5	-	-	-	-	2410	-	-	-	-	500	-	-	-	-
44.0	-	-	-	-	2970	-	-	-	-	500	-	-	-	-
48.5	-	-	-	-	3695	-	-	-	-	500	-	-	-	-

Applicable standard: IEC 60502-1
 Flame retardant property: IEC 60332-3

*Depth of laying in ground 0.5 Mtr.
 Thermal resistivity of soil 1.2 K.m/W
 1 Core cables are considered with Trefoil touching.
 Un-armoured cables are not recommended for underground application.

600/1000 V LV POWER CABLES ARMOURED

SINGLE CORE COPPER CONDUCTOR, XLPE INSULATION, PVC BEDDING, ALUMINIUM WIRE ARMoured & PVC SHEATH, LOW VOLTAGE POWER CABLE.

APPLICATION

For outdoor installations in power stations, industrial plants and switchgears if mechanical protection is required or in applications where mechanical damages are expected to occur.

CONSTRUCTION

Multi-Stranded Annealed Plain Copper conductor, XLPE insulation, Extruded PVC Bedding, Aluminium Round Wire Armour and Overall Extruded PVC Outer Sheath.

1. Conductor

Annealed Plain Copper (Multi Stranded, Class-2)

2. Insulation

XLPE

3. Bedding

Extruded PVC

4. Armour

Aluminium Round Wire

5. Outer Sheath

Extruded Overall PVC Outer Sheath.

APPLICATION STANDARDS

Low Voltage Cables are designed and tested to meet the requirements of below standard:

- IEC 60502-1

Oman Cables can also supply a range of alternative designs to meet customer specified requirements.

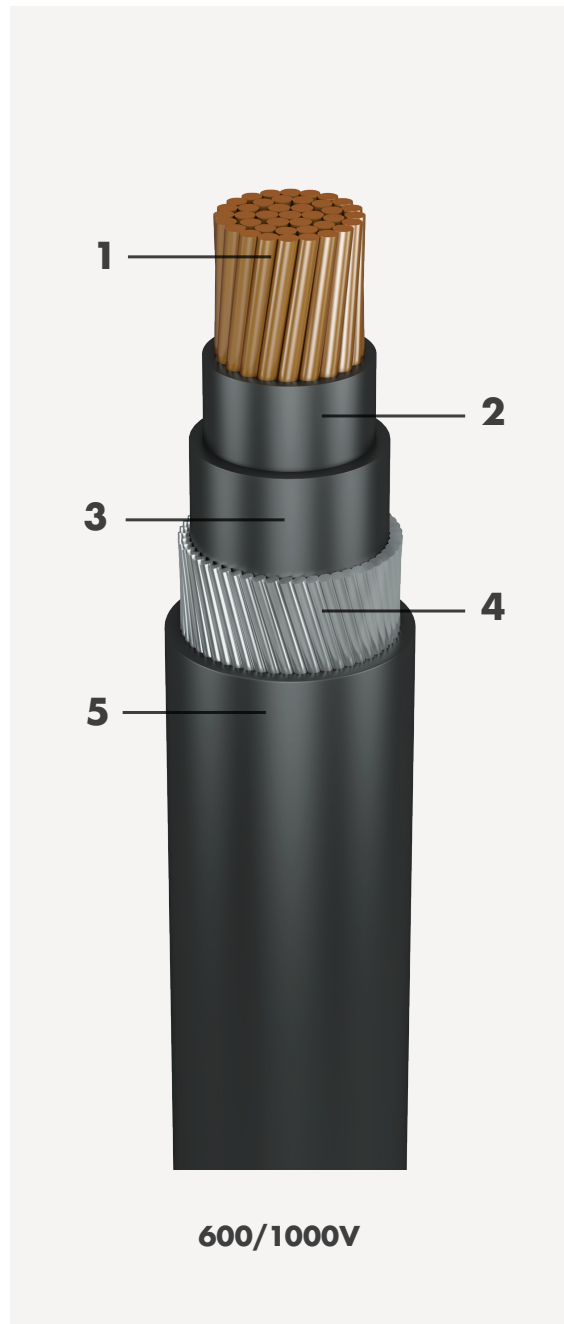

CORE COLOUR IDENTIFICATION

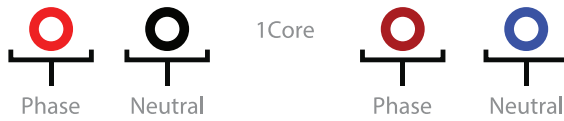

Note: Oman Cables has the capability to provide colour identification as per project requirements.

CHARACTERISTICS

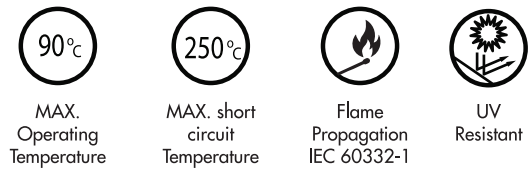

CABLE INSTALLATION

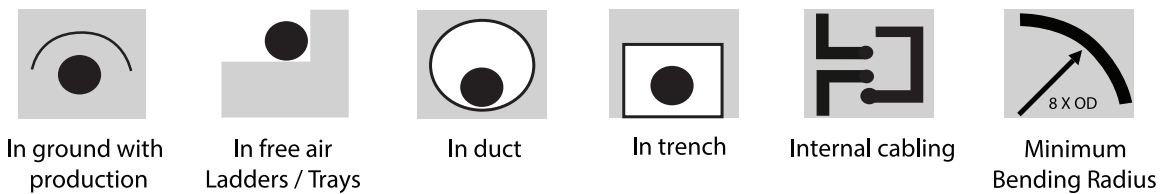

MULTI CORE

COPPER CONDUCTOR, XLPE INSULATION, PVC BEDDING, GALVANIZED STEEL ROUND WIRE ARMoured & PVC SHEATH, LOW VOLTAGE POWER CABLE.

APPLICATION

For outdoor installations in power stations, industrial plants and switchgears if mechanical protection is required or in applications where mechanical damages are expected to occur.

CONSTRUCTION

Stranded Annealed Plain Copper Conductor, XLPE insulation, Non-hygroscopic Fillers & Binder tape (as required), Extruded PVC Bedding, Galvanized Steel Round Wire Armoured and Overall Extruded PVC Outer Sheath.

1. Conductor

Annealed Plain Copper (Multi Stranded , Class-2)

2. Insulation

XLPE

3. Fillers & Binder Tape

Non-hygroscopic Fillers & binder tape

4. Bedding

Extruded PVC

5. Armour

Galvanised Steel Wire

6. Outer Sheath

Extruded Overall PVC Outer Sheath.

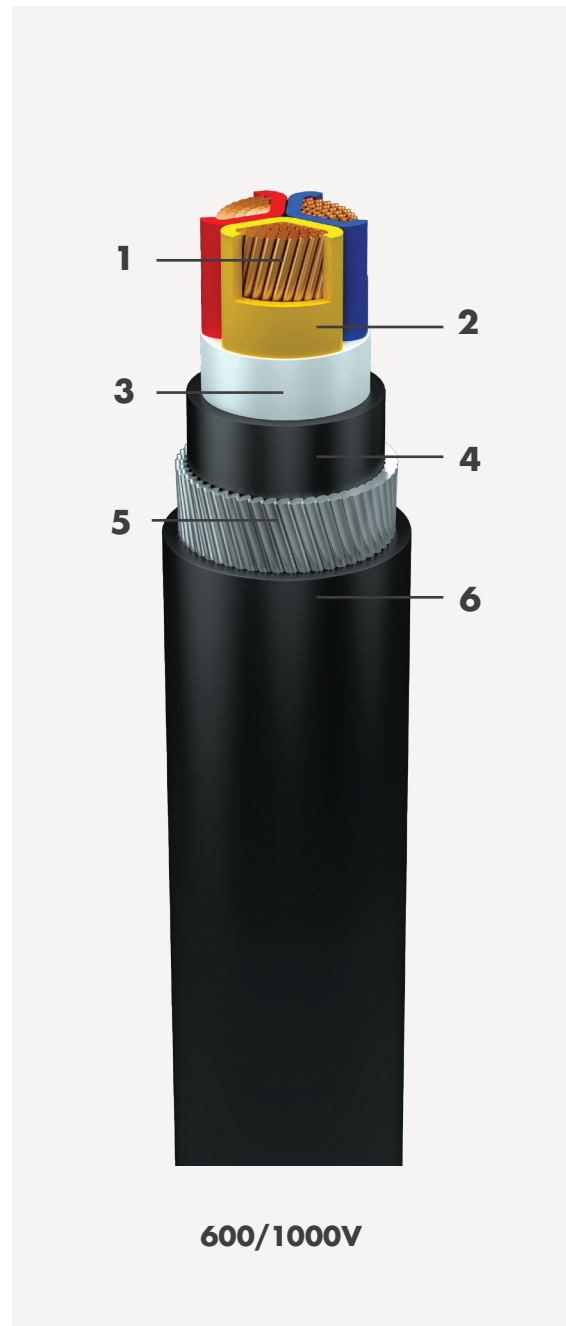

APPLICATION STANDARDS

Low Voltage Cables are designed and tested to meet the requirements of below standard:

- IEC 60502-1

Oman Cables can also supply a range of alternative designs to meet customer specified requirements.

CORE COLOUR IDENTIFICATION



Note: Oman Cables has the capability to provide colour identification as per project requirements.

CHARACTERISTICS

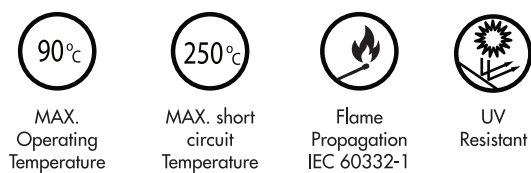

CABLE INSTALLATION

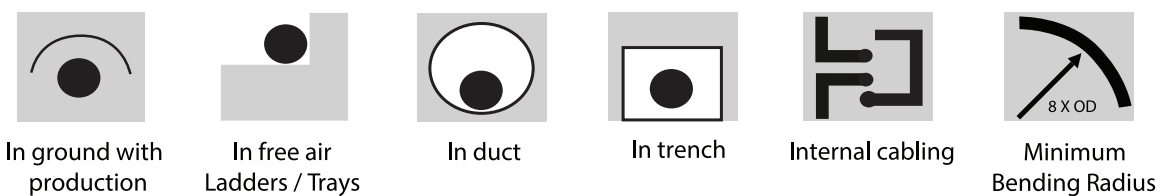

Cable size (mm ²)	Electrical Parameters						Current Rating *														
	DC Resistance (Ω/km)	AC Resistance (Ω/km)	Reactance (Approx.) at 50Hz. (Ω/km)		Impedance (Approx.) at 50Hz. (Ω/km)		Voltage Drop (Approx.) (mV/A/m)			Ground at 35°C, (A)				Duct at 35°C, (A)				Air at 50°C, (A)			
			1 C	Multi-core	1 C	Multi-core	1 C	2 C	3/4/5 C	1 C	2 C	3/4 C	5 C	1 C	2 C	3/4 C	5 C	1 C	2 C	3/4 C	5 C
1.5	12.1	15.43	-	0.105	-	15.43	-	30.86	26.73	-	33	28	24	-	27	22	19	-	24	20	17
2.5	7.41	9.45	-	0.099	-	9.45	-	18.90	16.37	-	42	36	30	-	35	29	25	-	32	27	23
4	4.61	5.88	-	0.093	-	5.88	-	11.76	10.18	-	56	47	40	-	46	39	33	-	43	37	31
6	3.08	3.93	-	0.089	-	3.93	-	7.86	6.81	-	70	59	50	-	58	48	42	-	55	46	40
10	1.83	2.33	0.13	0.084	2.33	2.33	4.040	4.66	4.04	82	94	79	68	78	77	65	55	67	74	64	53
16	1.15	1.47	0.121	0.081	1.47	1.47	2.550	2.94	2.55	108	121	102	87	101	99	83	71	92	98	83	71
25	0.727	0.928	0.118	0.081	0.935	0.932	1.620	1.86	1.61	139	157	131	113	134	127	107	91	123	128	109	92
35	0.524	0.669	0.113	0.079	0.678	0.674	1.170	1.35	1.17	165	188	157	135	154	153	128	110	146	158	134	114
50	0.387	0.494	0.11	0.078	0.506	0.501	0.880	1.00	0.87	199	223	187	161	199	181	152	130	180	190	163	137
70	0.268	0.343	0.103	0.074	0.358	0.351	0.620	0.70	0.61	244	273	229	197	239	224	187	161	230	239	205	172
95	0.193	0.247	0.099	0.072	0.266	0.258	0.460	0.52	0.45	292	328	274	236	281	269	226	194	282	295	253	212
120	0.153	0.197	0.099	0.072	0.22	0.21	0.380	0.42	0.36	332	372	312	268	315	307	258	221	328	341	293	246
150	0.124	0.16	0.096	0.073	0.187	0.177	0.320	0.35	0.31	371	417	349	300	341	345	291	248	377	389	335	280
185	0.0991	0.128	0.095	0.072	0.159	0.149	0.280	0.30	0.26	417	470	394	338	376	391	329	282	433	449	386	323
240	0.0754	0.099	0.092	0.071	0.135	0.123	0.230	0.25	0.21	480	544	455	392	421	453	380	326	510	530	456	382
300	0.0601	0.08	0.089	0.071	0.12	0.108	0.210	0.22	0.19	536	609	509	438	459	509	427	366	581	605	519	436
400	0.047	0.064	0.089	0.07	0.11	0.096	0.190	0.19	0.17	594	687	574	495	488	575	490	414	664	696	597	501
500	0.0366	0.052	0.087	0.07	0.101	0.088	0.170	0.18	0.15	658	758	633	-	529	634	541	-	751	768	659	-
630	0.0283	0.042	0.085	0.07	0.095	0.083	0.160	0.17	0.14	723	843	705	-	571	706	602	-	846	854	733	-
800	0.0221	0.035	0.085	-	0.092	-	0.160	-	-	764	-	-	-	595	-	-	-	919	-	-	-
1000	0.0176	0.031	0.084	-	0.09	-	0.160	-	-	810	-	-	-	632	-	-	-	997	-	-	-

Physical Dimensions														
Approx. Cable OD, mm				Approx. Cable Weight, kg/km					Standard Drum Length, m					
1 C	2 C	3 C	4 C	5 C	1 C	2 C	3 C	4 C	5 C	1 C	2 C	3 C	4 C	5 C
-	13.0	13.5	14	15	-	265	290	325	370	-	1000	1000	1000	1000
-	13.5	14.0	15	16	-	310	340	390	450	-	1000	1000	1000	1000
-	14.5	15.5	16.5	18	-	370	420	480	620	-	1000	1000	1000	1000
-	16.0	16.5	18.5	20	-	445	510	660	760	-	1000	1000	1000	1000
11.5	18.5	19.0	21	22.5	205	645	745	870	1000	1000	1000	1000	1000	1000
12.0	20.0	21.0	23.5	25	270	780	960	1245	1430	1000	1000	1000	1000	1000
14.0	20.5	22.5	25.5	29.5	380	985	1300	1640	1995	1000	1000	1000	1000	1000
15.0	22.5	25.0	28	32.5	480	1230	1640	2075	2540	1000	1000	1000	1000	500
17.0	25.0	28.0	30.5	37.5	645	1530	2085	2630	3600	1000	1000	1000	500	500
19.0	28.0	32.5	36	43	855	2030	2955	3760	4805	1000	1000	500	500	500
21.0	31.5	35.5	39.5	49	1130	2765	3805	4870	6625	1000	500	500	500	500
23.5	33.5	39.5	46.5	54	1420	3310	4650	6310	8105	1000	500	500	500	500
25.0	37.0	44.5	50.5	59	1710	3995	5935	7600	9720	1000	500	500	500	500
27.5	41.0	47.5	55.5	65	2090	5075	7090	9235	11905	1000	500	500	500	250
30.0	48.0	59.5	61.5	72	2670	6450	9325	11700	15095	1000	500	500	250	250
32.5	52.0	59.5	67	80.5	3265	7845	11040	14285	19120	500	500	500	250	250
37.0	57.5	63.5	77	90	4200	9735	13690	18605	23855	500	500	250	250	250
40.5	62.5	71.5	82.5	-	5285	12525	17785	23150	-	500	250	250.0	250	-
45.0	69.5	79.0	92	-	6710	15770	22385	29335	-	500	250	250.0	250	-
51.0	-	-	-	-	8640	-	-	-	-	500	-	-	-	-
56.0	-	-	-	-	10685	-	-	-	-	500	-	-	-	-

Applicable standard: IEC 60502-1
Flame retardant property: IEC 60332-1

*Depth of laying in ground 0.5 Mtr.
Thermal resistivity of soil 1.2 K.m/W
1 Core cables are considered with Trefoil touching.

SINGLE CORE

ALUMINIUM CONDUCTOR, XLPE INSULATION, PVC BEDDING, ALUMINIUM WIRE ARMoured & PVC SHEATH, LOW VOLTAGE POWER CABLE.

APPLICATION

For outdoor installations in power stations, industrial plants and switchgears if mechanical protection is required or in applications where mechanical damages are expected to occur.

CONSTRUCTION

Multi-Stranded Aluminium conductor, XLPE insulation, Extruded PVC Bedding, Aluminium Round Wire Armour and Overall Extruded PVC Outer Sheath.

1. Conductor

Aluminium (Multi Stranded, Class-2)

2. Insulation

XLPE

3. Bedding

Extruded PVC

4. Armour

Aluminium Round Wire

5. Outer Sheath

Extruded Overall PVC Outer Sheath.

APPLICATION STANDARDS

Low Voltage Cables are designed and tested to meet the requirements of below standard:

- IEC 60502-1

Oman Cables can also supply a range of alternative designs to meet customer specified requirements.

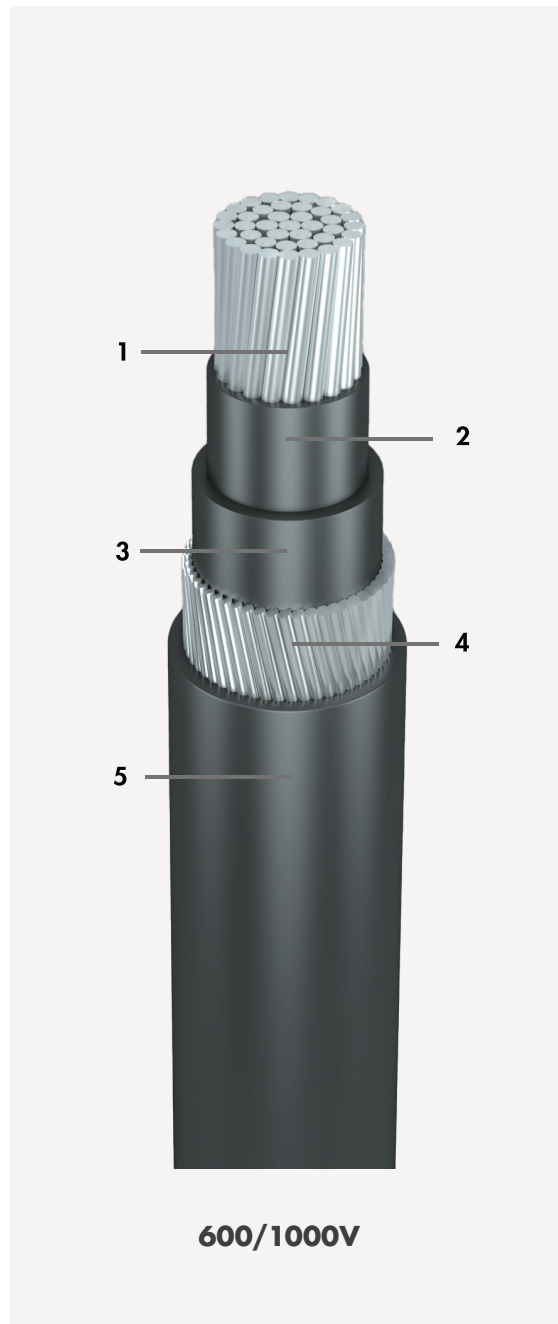

CORE COLOUR IDENTIFICATION

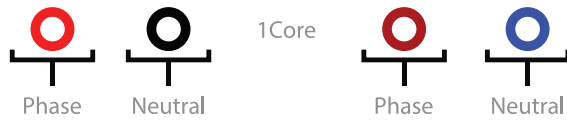

Note: Oman Cables has the capability to provide colour identification as per project requirements.

CHARACTERISTICS

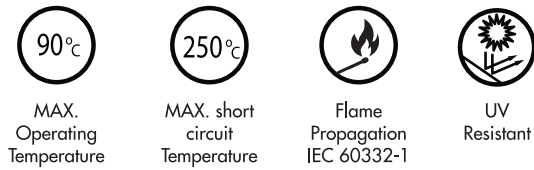

CABLE INSTALLATION

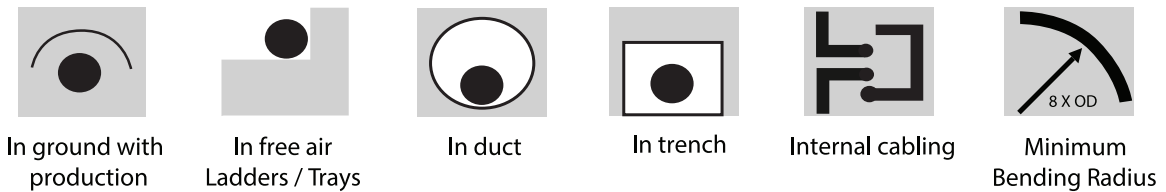

MULTI CORE

ALUMINIUM CONDUCTOR, XLPE INSULATION, PVC BEDDING, GALVANIZED STEEL ROUND WIRE ARMoured & PVC SHEATH, LOW VOLTAGE POWER CABLE.

APPLICATION

For outdoor installations in power stations, industrial plants and switchgears if mechanical protection is required or in applications where mechanical damages are expected to occur.

CONSTRUCTION

Stranded Aluminium Conductor, XLPE insulation, Non-hygroscopic Fillers & Binder tape (as required), , Extruded PVC Bedding, Galvanized Steel Round Wire Armoured and Overall Extruded PVC Outer Sheath.

1. Conductor

Aluminium (Multi Stranded, Class-2)

2. Insulation

XLPE

3. Fillers & Binder Tape

Non-hygroscopic Fillers & binder tape

4. Bedding

Extruded PVC

5. Armour

Galvanized Steel Wire

6. Outer Sheath

Extruded Overall PVC Outer Sheath.

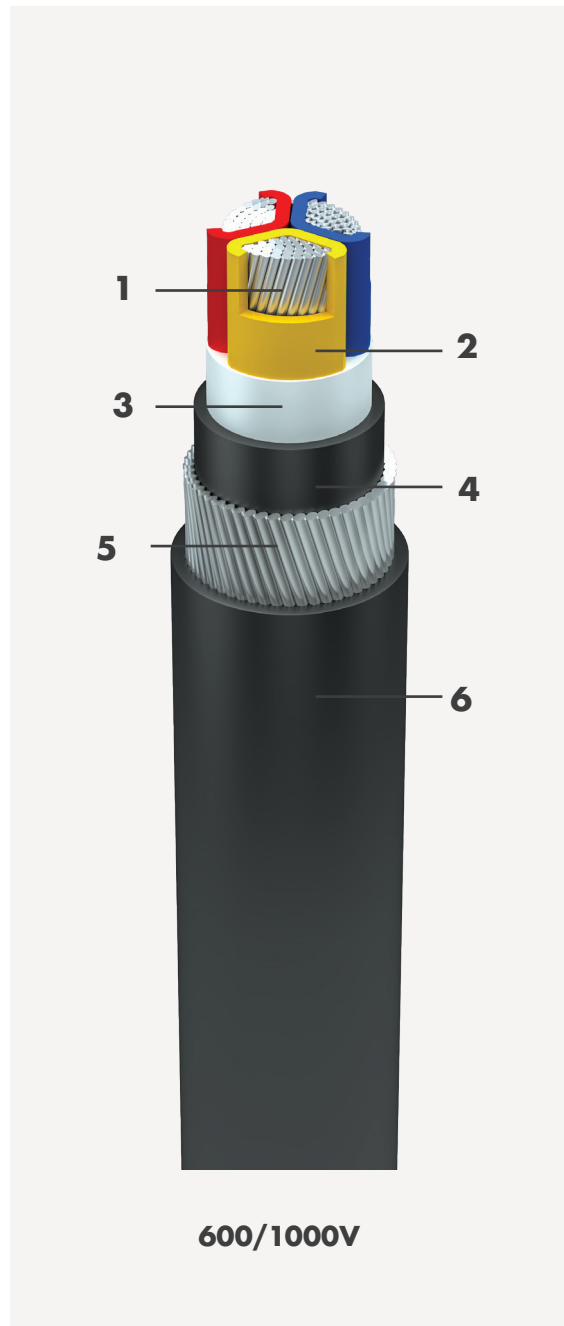

APPLICATION STANDARDS

Low Voltage Cables are designed and tested to meet the requirements of below standard:

- IEC 60502-1

Oman Cables can also supply a range of alternative designs to meet customer specified requirements.

CORE COLOUR IDENTIFICATION



Note: Oman Cables has the capability to provide colour identification as per project requirements.

CHARACTERISTICS

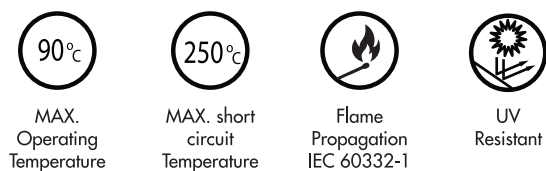

CABLE INSTALLATION

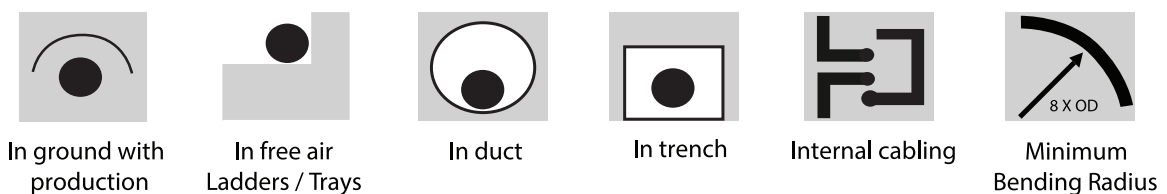

Cable size (mm ²)	Electrical Parameters					Current Rating *															
	DC Resistance (Ω /km)	AC Resistance (Approx.) at 50Hz. (Ω /km)		Impedance (Approx.) at 50Hz. (Ω /km)		Voltage Drop (Approx.) (mV/A/m)			Ground at 35°C, (A)			Duct at 35°C, (A)			Air at 50°C, (A)						
		1 C	Multi-core	1 C	Multi-core	1 C	2 C	3/4/5 C	1 C	2 C	3/4 C	5 C	1 C	2 C	3/4 C	5 C	1 C	2 C	3/4 C	5 C	
1.5	-	-	-	-	-	-	-	-	-	-	-	-	-	-	-	-	-	-	-	-	
2.5	-	-	-	-	-	-	-	-	-	-	-	-	-	-	-	-	-	-	-	-	
4	-	-	-	-	-	-	-	-	-	-	-	-	-	-	-	-	-	-	-	-	
6	-	-	-	-	-	-	-	-	-	-	-	-	-	-	-	-	-	-	-	-	
10	-	-	-	-	-	-	-	-	-	-	-	-	-	-	-	-	-	-	-	-	
16	1.91	2.45	0.121	0.081	2.45	2.45	4.24	4.9	4.24	84	93	78	67	79	76	64	55	72	74	63	53
25	1.2	1.54	0.118	0.081	1.54	1.54	2.67	3.08	2.67	109	119	100	86	103	96	82	69	94	95	83	68
35	0.868	1.11	0.113	0.079	1.12	1.11	1.92	2.22	1.92	127	142	120	102	123	116	97	84	118	116	101	84
50	0.641	0.823	0.11	0.078	0.83	0.827	1.440	1.65	1.43	152	169	142	122	153	138	116	99	135	140	122	101
70	0.443	0.569	0.103	0.074	0.578	0.574	1.000	1.15	0.99	187	207	175	149	186	169	144	122	172	177	154	127
95	0.32	0.411	0.099	0.072	0.423	0.418	0.730	0.84	0.72	224	248	210	179	219	204	173	147	211	218	190	157
120	0.253	0.326	0.099	0.072	0.341	0.334	0.590	0.67	0.58	255	266	239	192	248	232	198	167	245	235	221	169
150	0.206	0.265	0.096	0.073	0.282	0.276	0.490	0.55	0.48	285	304	267	219	271	256	223	184	282	269	253	194
185	0.164	0.212	0.095	0.072	0.232	0.224	0.400	0.45	0.39	322	349	304	251	301	293	253	211	325	308	293	222
240	0.125	0.162	0.092	0.071	0.186	0.178	0.320	0.36	0.31	372	406	352	292	341	336	294	242	385	364	346	262
300	0.1	0.13	0.089	0.071	0.158	0.15	0.270	0.3	0.26	418	450	396	324	377	372	332	268	441	409	396	294
400	0.0778	0.102	0.089	0.07	0.135	0.125	0.230	0.25	0.22	481	492	428	354	415	425	357	306	526	470	420	338
500	0.0605	0.081	0.087	0.07	0.119	0.109	0.210	-	0.19	534	-	479	-	451	-	400	-	595	-	470	-
630	0.0469	0.064	0.085	0.07	0.106	0.096	0.180	-	0.17	589	-	536	-	485	-	447	-	672	-	526	-
800	0.0367	0.052	0.085	-	0.1	-	0.170	-	-	649	-	-	-	520	-	-	-	760	-	-	-
1000	0.0291	0.044	0.084	-	0.095	-	0.160	-	-	706	-	-	-	559	-	-	-	843	-	-	-

Physical Dimensions														
Approx. Cable OD, mm				Approx. Cable Weight, kg/km					Standard Drum Length, m					
1 C	2 C	3 C	4 C	5 C	1 C	2 C	3 C	4 C	5 C	1 C	2 C	3 C	4 C	5 C
-	-	-	-	-	-	-	-	-	-	-	-	-	-	-
-	-	-	-	-	-	-	-	-	-	-	-	-	-	-
-	-	-	-	-	-	-	-	-	-	-	-	-	-	-
-	-	-	-	-	-	-	-	-	-	-	-	-	-	-
-	-	-	-	-	-	-	-	-	-	-	-	-	-	-
12	20	21	24	25	175	590	670	860	950	1000	1000	1000	1000	1000
14	21	23	26	30	230	680	840	1030	1240	1000	1000	1000	1000	1000
15	23	25	28	33	270	805	1000	1225	1480	1000	1000	1000	1000	500
17	25	28	31	38	360	955	1220	1480	2175	1000	1000	1000	500	500
19	28	33	36	43	450	1200	1710	2100	2765	1000	1000	500	500	500
21	32	36	40	49	560	1610	2080	2565	3755	1000	500	500	500	500
24	34	40	47	54	700	1850	2460	3390	4470	1000	500	500	500	500
25	37	45	51	59	820	2180	3215	3975	5235	1000	500	500	500	500
28	41	48	56	65	980	2825	3710	4730	6310	1000	500	500	500	250
30	48	54	62	72	1205	3500	4595	5795	7695	1000	500	500	250	250
33	52	60	67	81	1425	4120	5455	6835	9840	500	500	500	250	250
37	58	64	77	90	1855	4930	6485	9000	12040	500	500	250	250	250
41	-	72	83	-	2255	-	8440	10685	-	500	-	250	250	-
45	-	79	92	-	2800	-	10345	13285	-	500	-	250	250	-
51	-	-	-	-	3600	-	-	-	-	500	-	-	-	-
56	-	-	-	-	4375	-	-	-	-	500	-	-	-	-

Applicable standard: IEC 60502-1
 Flame retardant property: IEC 60332-1

*Depth of laying in ground 0.5 Mtr.
 Thermal resistivity of soil 1.2 K.m/W
 1 Core cables are considered with Trefoil touching.

SINGLE CORE COPPER CONDUCTOR, XLPE INSULATION, PVC BEDDING, ALUMINIUM WIRE ARMoured & PVC SHEATH, LOW VOLTAGE POWER CABLE.

APPLICATION

For outdoor installations in power stations, industrial plants and switchgears if mechanical protection is required or in applications where mechanical damages are expected to occur.

CONSTRUCTION

Multi-Stranded Annealed Plain Copper conductor, XLPE insulation, Extruded PVC Bedding, Aluminium Round Wire Armour and Overall Extruded PVC Outer Sheath.

1. Conductor

Annealed Plain Copper (Multi Stranded, Class-2)

2. Insulation

XLPE

3. Bedding

Extruded PVC

4. Armour

Aluminium Round Wire

5. Outer Sheath

Extruded Overall PVC Outer Sheath.

APPLICATION STANDARDS

Low Voltage Cables are designed and tested to meet the requirements of below standard:

- BS 5467

Oman Cables can also supply a range of alternative designs to meet customer specified requirements.

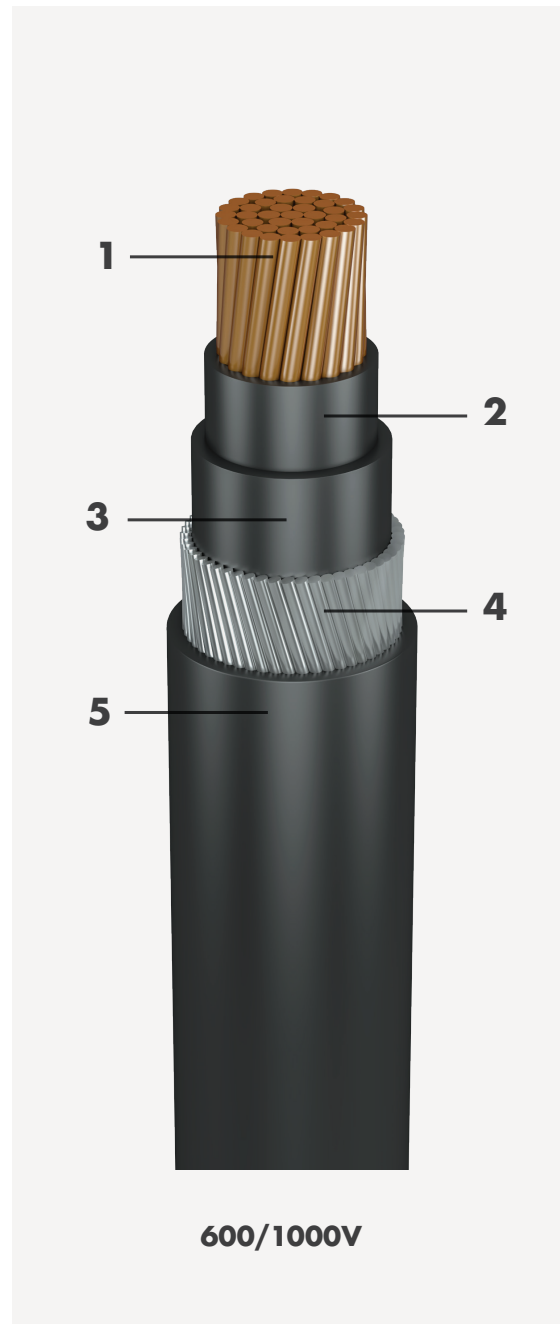

CORE COLOUR IDENTIFICATION

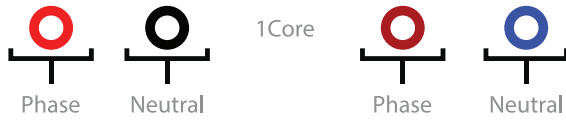

Note: Oman Cables has the capability to provide colour identification as per project requirements.

CHARACTERISTICS

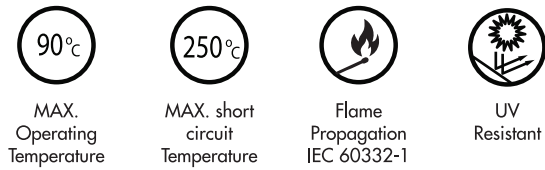

CABLE INSTALLATION

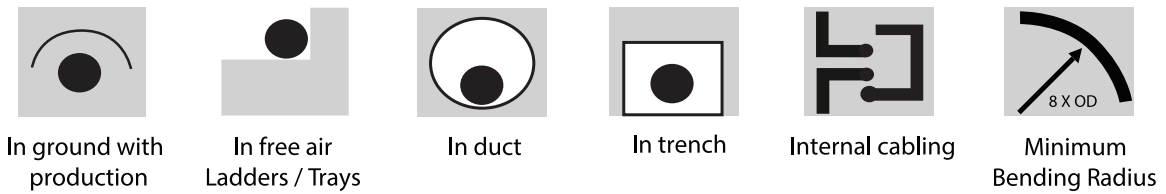

MULTI CORE

COPPER CONDUCTOR, XLPE INSULATION, PVC BEDDING, GALVANIZED STEEL ROUND WIRE ARMoured & PVC SHEATH, LOW VOLTAGE POWER CABLE.

APPLICATION

For outdoor installations in power stations, industrial plants and switchgears if mechanical protection is required or in applications where mechanical damages are expected to occur.

CONSTRUCTION

Stranded Annealed Plain Copper Conductor, XLPE insulation, Non-hygroscopic Fillers & Binder tape (as required), Extruded PVC Bedding, Galvanized Steel Round Wire Armoured and Overall Extruded PVC Outer Sheath.

1. Conductor

Annealed Plain Copper (Multi Stranded, Class-2)

2. Insulation

XLPE

3. Fillers & Binder Tape

Non-hygroscopic Fillers & binder tape

4. Bedding

Extruded PVC

5. Armour

Galvanized Steel Wire

6. Outer Sheath

Extruded Overall PVC Outer Sheath.

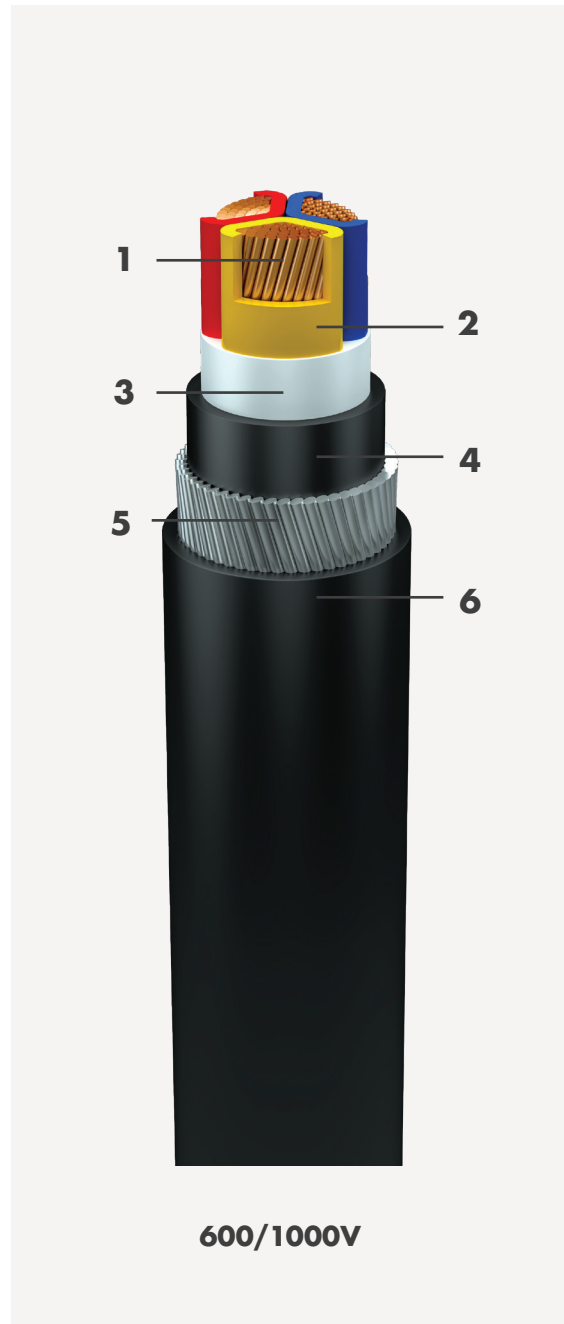

APPLICATION STANDARDS

Low Voltage Cables are designed and tested to meet the requirements of below standard:

- BS 5467

Oman Cables can also supply a range of alternative designs to meet customer specified requirements.

CORE COLOUR IDENTIFICATION



Note: Oman Cables has the capability to provide colour identification as per project requirements.

CHARACTERISTICS

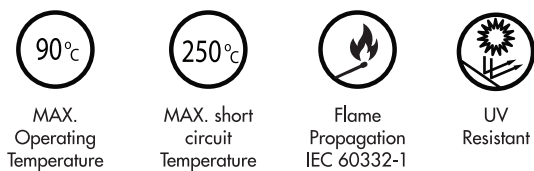

CABLE INSTALLATION

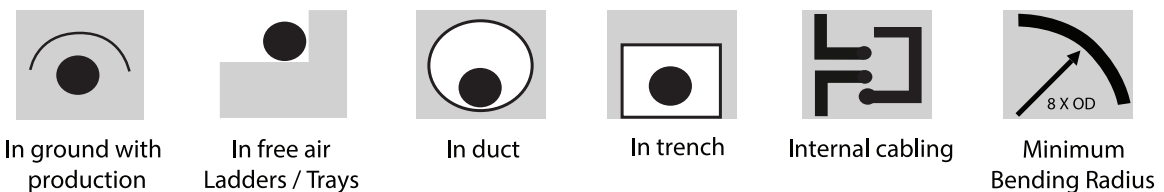

Cable size (mm ²)	Electrical Parameters						Current Rating *														
	DC Resistance (Ω/km)	AC Resistance (Approx.) at 50Hz. (Ω/km)	Reactance (Approx.) at 50Hz. (Ω/km)		Impedance (Approx.) at 50Hz. (Ω/km)		Voltage Drop (Approx.) (mV/A/m)			Ground at 35°C, (A)				Duct at 35°C, (A)				Air at 50°C, (A)			
			1 C	Multi-core	1 C	Multi-core	1 C	2 C	3/4/5 C	1 C	2 C	3/4 C	5 C	1 C	2 C	3/4 C	5 C	1 C	2 C	3/4 C	5 C
1.5	12.1	15.43	-	0.105	-	15.43	-	30.86	26.73	-	33	28	24	-	27	22	19	-	24	20	17
2.5	7.41	9.45	-	0.099	-	9.45	-	18.90	16.37	-	42	36	30	-	35	29	25	-	32	27	23
4	4.61	5.88	-	0.093	-	5.88	-	11.76	10.18	-	56	47	40	-	46	39	33	-	43	37	31
6	3.08	3.93	-	0.089	-	3.93	-	7.86	6.81	-	70	59	50	-	58	48	42	-	55	46	40
10	1.83	2.33	0.13	0.084	2.33	2.33	4.040	4.66	4.04	82	94	79	68	78	77	65	55	67	74	64	53
16	1.15	1.47	0.121	0.081	1.47	1.47	2.550	2.94	2.55	108	121	102	87	101	99	83	71	92	98	83	71
25	0.727	0.928	0.118	0.081	0.935	0.932	1.620	1.86	1.61	139	157	131	113	134	127	107	91	123	128	109	92
35	0.524	0.669	0.113	0.079	0.678	0.674	1.170	1.35	1.17	165	188	157	135	154	153	128	110	146	158	134	114
50	0.387	0.494	0.11	0.078	0.506	0.501	0.880	1.00	0.87	199	223	187	161	199	181	152	130	180	190	163	137
70	0.268	0.343	0.103	0.074	0.358	0.351	0.620	0.70	0.61	244	273	229	197	239	224	187	161	230	239	205	172
95	0.193	0.247	0.099	0.072	0.266	0.258	0.460	0.52	0.45	292	328	274	-	281	269	226	-	282	295	253	-
120	0.153	0.197	0.099	0.072	0.22	0.21	0.380	0.42	0.36	332	372	312	-	315	307	258	-	328	341	293	-
150	0.124	0.16	0.096	0.073	0.187	0.177	0.320	0.35	0.31	371	417	349	-	341	345	291	-	377	389	335	-
185	0.0991	0.128	0.095	0.072	0.159	0.149	0.280	0.30	0.26	417	470	394	-	376	391	329	-	433	449	386	-
240	0.0754	0.099	0.092	0.071	0.135	0.123	0.230	0.25	0.21	480	544	455	-	421	453	380	-	510	530	456	-
300	0.0601	0.08	0.089	0.071	0.12	0.108	0.210	0.22	0.19	536	609	509	-	459	509	427	-	581	605	519	-
400	0.047	0.064	0.089	0.07	0.11	0.096	0.190	0.19	0.17	594	687	574	-	488	575	490	-	664	696	597	-
500	0.0366	0.052	0.087	-	0.101	-	0.170	-	-	658	-	-	-	529	-	-	-	751	-	-	-
630	0.0283	0.042	0.085	-	0.095	-	0.160	-	-	723	-	-	-	571	-	-	-	846	-	-	-
800	0.0221	0.035	0.085	-	0.092	-	0.160	-	-	764	-	-	-	595	-	-	-	919	-	-	-
1000	0.0176	0.031	0.084	-	0.09	-	0.160	-	-	810	-	-	-	632	-	-	-	997	-	-	-

Physical Dimensions														
Approx. Cable OD, mm					Approx. Cable Weight, kg/km					Standard Drum Length, m				
1 C	2 C	3 C	4 C	5 C	1 C	2 C	3 C	4 C	5 C	1 C	2 C	3 C	4 C	5 C
-	11.5	12.0	13.0	14.0	-	275	290	325	370	-	1000	1000	1000	1000
-	12.5	13.0	14.0	15.0	-	340	340	390	450	-	1000	1000	1000	1000
-	13.5	14.5	15.5	16.5	-	415	420	480	555	-	1000	1000	1000	1000
-	15.0	15.5	17.5	19.0	-	505	510	660	760	-	1000	1000	1000	1000
11.5	17.0	18.5	20.0	21.5	210	775	745	870	1000	1000	1000	1000	1000	1000
12.0	19.5	20.5	22.0	25.0	270	990	960	1245	1520	1000	1000	1000	1000	1000
13.5	19.0	22.0	25.5	29.5	380	1385	1300	1640	2125	1000	1000	1000	1000	1000
14.5	22.0	25.0	28.0	32.5	480	1735	1640	2075	2680	1000	1000	1000	1000	500
16.0	25.0	27.5	30.5	37.5	615	2170	2085	2630	3785	1000	1000	1000	500	500
18.5	27.5	31.0	36.0	42.5	870	2855	2955	3760	5040	1000	1000	500	500	500
20.5	31.0	35.5	39.5	-	1145	3920	3805	4870	-	1000	500	500	500	-
22.0	33.5	39.0	46.0	-	1395	4760	4650	6310	-	1000	500	500	500	-
25.0	37.0	44.5	50.0	-	1755	6140	5935	7600	-	1000	500	500	500	-
27.5	41.0	47.0	55.5	-	2150	7370	7090	9235	-	1000	500	500	500	-
30.0	47.5	53.0	61.0	-	2725	9260	9325	11700	-	1000	500	500	250	-
32.5	52.0	59.0	66.5	-	3335	11250	11040	14285	-	500	500	500	250	-
37.0	57.0	63.0	76.5	-	4275	13975	13690	18605	-	500	500	250	250	-
40.5	-	-	-	-	5360	-	-	-	-	500	-	-	-	-
44.5	-	-	-	-	6800	-	-	-	-	500	-	-	-	-
51.0	-	-	-	-	8765	-	-	-	-	500	-	-	-	-
55.5	-	-	-	-	10785	-	-	-	-	500	-	-	-	-

Applicable standard: BS 5467
Flame retardant property: IEC 60332-1

*Depth of laying in ground 0.5 Mtr.
Thermal resistivity of soil 1.2 K.m/W
1 Core cables are considered with Trefoil touching.

SINGLE CORE COPPER CONDUCTOR, PVC (TYPE A) INSULATION, PVC BEDDING, ALUMINIUM WIRE ARMoured & PVC SHEATH, LOW VOLTAGE POWER CABLE.

APPLICATION

For outdoor installations in power stations, industrial plants and switchgears if mechanical protection is required or in applications where mechanical damages are expected to occur.

CONSTRUCTION

Multi-Stranded Annealed Plain Copper conductor, PVC (TYPE A) insulation, Extruded PVC Bedding, Aluminium Round Wire Armour and Overall Extruded PVC Outer Sheath.

1. Conductor

Annealed Plain Copper (Multi Stranded, Class-2)

2. Insulation

Extruded PVC (TYPE A)

3. Bedding

Extruded PVC

4. Armour

Aluminium Round Wire

5. Outer Sheath

Extruded Overall PVC Outer Sheath.

APPLICATION STANDARDS

Low Voltage Cables are designed and tested to meet the requirements of below standard:

- IEC 60502-1

Oman Cables can also supply a range of alternative designs to meet customer specified requirements.

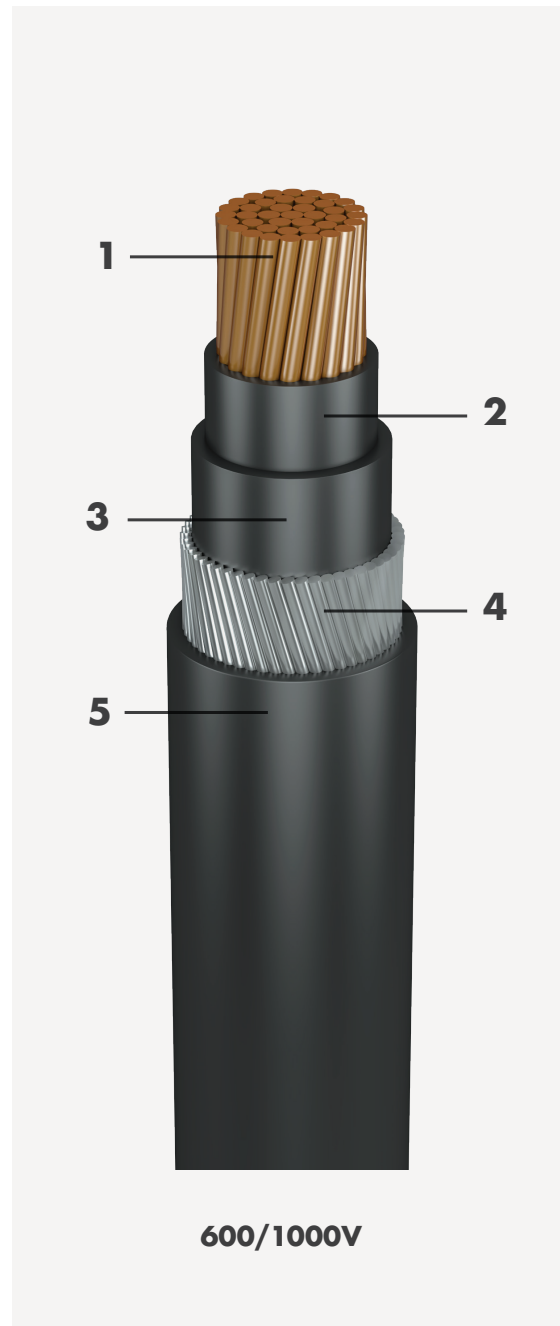

CORE COLOUR IDENTIFICATION

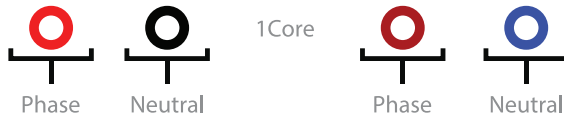

Note: Oman Cables has the capability to provide colour identification as per project requirements.

CHARACTERISTICS

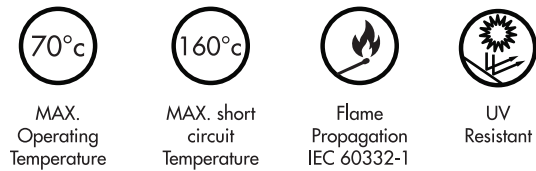

CABLE INSTALLATION

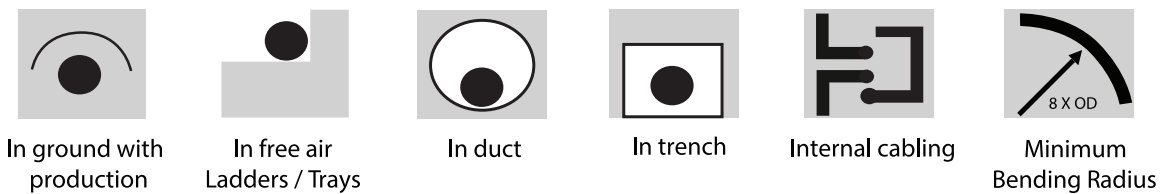

MULTI CORE

COPPER CONDUCTOR, PVC (TYPE A) INSULATION, PVC BEDDING, GALVANIZED STEEL ROUND WIRE ARMoured & PVC SHEATH, LOW VOLTAGE POWER CABLE.

APPLICATION

For outdoor installations in power stations, industrial plants and switchgears if mechanical protection is required or in applications where mechanical damages are expected to occur.

CONSTRUCTION

Stranded Annealed Plain Copper Conductor, PVC (TYPE A) insulation, Non-hygroscopic Fillers & Binder tape (as required), Extruded PVC Bedding, Galvanized Steel Round Wire Armoured and Overall Extruded PVC Outer Sheath.

1. Conductor

Annealed Plain Copper (Multi Stranded, Class-2)

2. Insulation

Extruded PVC (TypeA)

3. Fillers & Binder Tape

Non-hygroscopic Fillers & binder tape

4. Bedding

Extruded PVC

5. Armour

Galvanized Steel Wire

6. Outer Sheath

Extruded Overall PVC Outer Sheath.

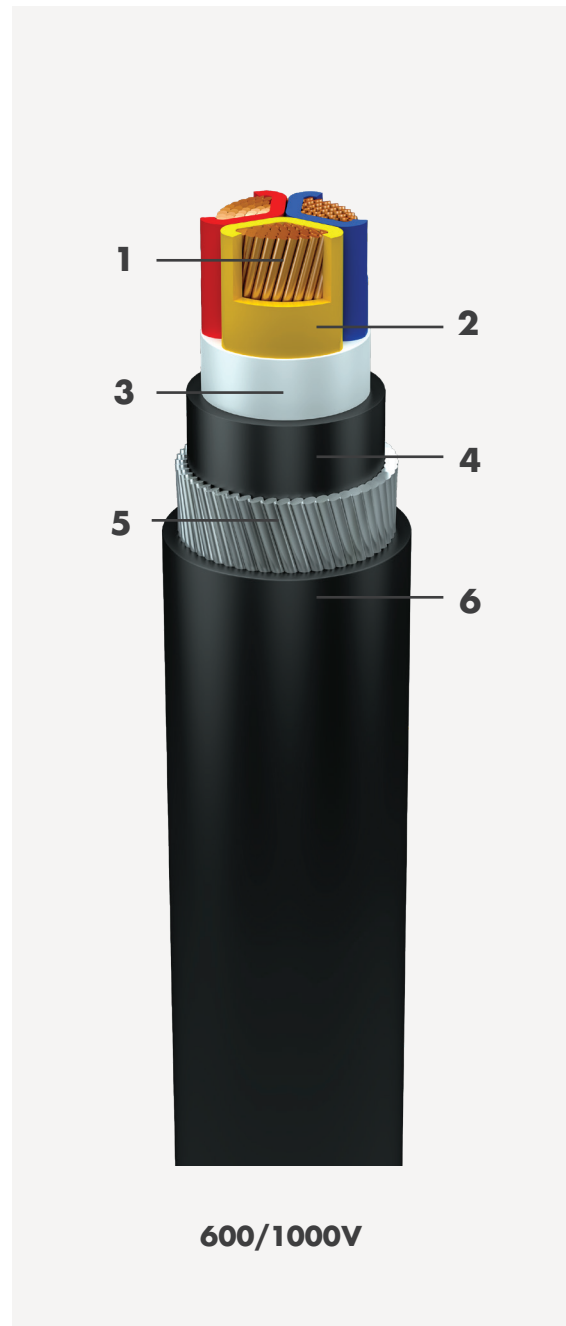

APPLICATION STANDARDS

Low Voltage Cables are designed and tested to meet the requirements of below standard:

- IEC 60502-1

Oman Cables can also supply a range of alternative designs to meet customer specified requirements.

CORE COLOUR IDENTIFICATION



Note: Oman Cables has the capability to provide colour identification as per project requirements.

CHARACTERISTICS

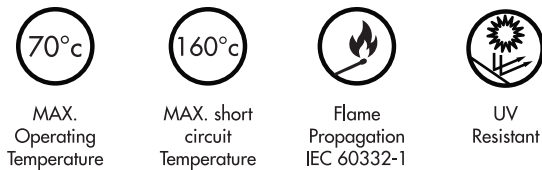

CABLE INSTALLATION

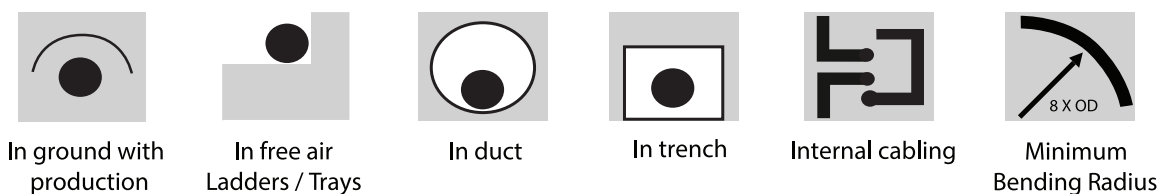

Cable size (mm ²)	Electrical Parameters						Current Rating *														
	DC Resistance (Ω/km)	AC Resistance (Ω/km)	Reactance (Approx.) at 50Hz. (Ω/km)		Impedance (Approx.) at 50Hz. (Ω/km)		Voltage Drop (Approx.) (mV/A/m)			Ground at 35°C, (A)				Duct at 35°C, (A)				Air at 50°C, (A)			
			1 C	Multi-core	1 C	Multi-core	1 C	2 C	3/4/5 C	1 C	2 C	3/4 C	5 C	1 C	2 C	3/4 C	5 C	1 C	2 C	3/4 C	5 C
1.5	12.1	14.48	-	0.110	-	-	-	28.96	25.09	-	26	22	19	-	21	18	15	-	16	14	12
2.5	7.41	8.87	-	0.103	-	8.870	-	17.74	15.36	-	33	28	24	-	27	23	19	-	22	19	16
4	4.61	5.52	-	0.102	-	5.520	-	11.04	9.56	-	44	38	32	-	36	30	26	-	29	25	21
6	3.08	3.69	-	0.097	-	3.690	-	7.38	6.39	-	55	47	40	-	46	38	33	-	38	32	27
10	1.83	2.19	0.132	0.091	2.19	2.190	3.79	4.38	3.79	68	74	62	53	64	61	51	44	49	52	44	37
16	1.15	1.38	0.124	0.087	1.39	1.380	2.41	2.76	2.39	89	95	81	68	84	78	66	56	67	68	58	49
25	0.727	0.871	0.118	0.085	0.878	0.875	1.52	1.75	1.52	115	126	106	91	111	103	86	74	90	91	78	66
35	0.524	0.628	0.113	0.083	0.638	0.633	1.11	1.27	1.10	136	152	127	109	127	123	103	89	107	111	95	80
50	0.387	0.464	0.112	0.083	0.477	0.471	0.83	0.94	0.82	162	180	150	130	159	146	122	105	129	135	115	97
70	0.268	0.322	0.103	0.077	0.338	0.331	0.59	0.66	0.57	198	222	186	160	193	180	152	130	163	169	146	122
95	0.193	0.233	0.101	0.077	0.253	0.245	0.44	0.49	0.42	238	266	223	192	226	217	182	156	200	209	180	150
120	0.153	0.195	0.100	0.075	0.21	0.200	0.36	0.40	0.35	270	302	254	217	249	247	208	178	232	241	208	174
150	0.124	0.151	0.098	0.075	0.179	0.169	0.31	0.34	0.29	301	338	284	243	274	277	234	199	265	274	238	197
185	0.0991	0.122	0.095	0.074	0.154	0.143	0.27	0.29	0.25	338	382	321	275	300	314	265	226	303	317	273	228
240	0.0754	0.094	0.093	0.074	0.132	0.120	0.23	0.24	0.21	388	441	370	318	335	364	306	262	356	374	322	269
300	0.0601	0.077	0.093	0.074	0.119	0.107	0.21	0.21	0.19	434	493	414	355	367	408	342	294	407	426	366	307
400	0.047	0.062	0.090	0.073	0.108	0.096	0.19	0.19	0.17	480	554	464	399	391	459	392	330	462	488	420	351
500	0.0366	0.051	0.088	0.072	0.101	0.088	0.17	0.18	0.15	528	611	512	-	418	506	432	-	520	538	463	-
630	0.0283	0.043	0.087	0.071	0.096	0.083	0.17	0.17	0.14	577	665	557	-	450	551	471	-	582	586	504	-
800	0.0221	0.034	0.086	-	0.092	-	0.16	-	-	605	-	-	-	470	-	-	-	628	-	-	-
1000	0.0176	0.029	0.084	-	0.089	-	0.15	-	-	638	-	-	-	497	-	-	-	677	-	-	-

Physical Dimensions														
Approx. Cable OD, mm				Approx. Cable Weight, kg/km					Standard Drum Length, m					
1 C	2 C	3 C	4 C	5 C	1 C	2 C	3 C	4 C	5 C	1 C	2 C	3 C	4 C	5 C
-	13.0	13.5	14.5	15.5	-	305	330	375	425	-	1000	1000	1000	1000
-	14.0	14.5	15.5	16.5	-	345	390	445	505	-	1000	1000	1000	1000
-	16.0	17.5	18.5	20.0	-	445	575	665	755	-	1000	1000	1000	1000
-	17.5	18.5	20.0	21.5	-	595	685	800	925	-	1000	1000	1000	1000
12.0	19.5	20.5	22.5	24.5	235	760	880	1005	1275	1000	1000	1000	1000	1000
13.0	21.5	22.5	25.0	27.0	300	885	1085	1415	1625	1000	1000	1000	1000	1000
14.5	21.5	23.5	27.0	31.5	415	1125	1465	1865	2265	1000	1000	1000	1000	500
15.5	23.5	26.0	29.5	35.0	520	1375	1830	2315	3025	1000	1000	1000	1000	500
18.0	26.5	29.5	34.0	40.0	705	1735	2345	3155	3995	1000	1000	1000	500	500
19.5	30.0	33.5	37.5	44.5	915	2380	3260	4095	5215	1000	1000	500	500	500
22.0	33.5	37.5	43.0	51.5	1215	3075	4225	5645	7285	1000	500	500	500	500
24.0	35.5	41.0	48.0	56.0	1515	3645	5065	6865	8770	1000	500	500	500	500
26.0	40.0	46.5	52.5	61.5	1820	4620	6435	8235	10525	1000	500	500	500	250
28.0	42.5	49.0	58.0	67.0	2215	5495	7690	10010	12725	1000	500	500	500	250
31.0	50.0	56.0	64.0	76.0	2825	7020	9760	12602	16815	500	500	500	250	250
34.5	54.5	62.0	70.0	84.0	3540	8525	11920	15365	20555	500	500	250	250	250
38.5	60.0	68.0	79.5	93.5	4435	10510	15325	19975	25410	500	500	250	250	250
42.0	65.5	74.0	85.5	-	5555	13555	19000	24715	-	500	250	250	250	-
46.0	71.5	81.0	94.0	-	6995	16675	23565	30805	-	500	250	250	250	-
51.5	-	-	-	-	8935	-	-	-	-	500	-	-	-	-
56.5	-	-	-	-	11025	-	-	-	-	500	-	-	-	-

Applicable standard: BS 5467
Flame retardant property: IEC 60332-1

*Depth of laying in ground 0.5 Mtr.
Thermal resistivity of soil 1.2 K.m/W
1 Core cables are considered with Trefoil touching.

SINGLE CORE

ALUMINIUM CONDUCTOR, PVC (TYPE A) INSULATION, PVC BEDDING, ALUMINIUM WIRE ARMoured & PVC SHEATH, LOW VOLTAGE POWER CABLE.

APPLICATION

For outdoor installations in power stations, industrial plants and switchgears if mechanical protection is required or in applications where mechanical damages are expected to occur.

CONSTRUCTION

Multi-Stranded Aluminium conductor, PVC (TYPE A) insulation, Extruded PVC Bedding, Aluminium Round Wire Armour and Overall Extruded PVC Outer Sheath.

1. Conductor

Aluminium (Multi Stranded, Class-2)

2. Insulation

Extruded PVC (TYPE A)

3. Bedding

Extruded PVC

4. Armour

Aluminium Round Wire

5. Outer Sheath

Extruded Overall PVC Outer Sheath.

APPLICATION STANDARDS

Low Voltage Cables are designed and tested to meet the requirements of below standard:

- IEC 60502-1

Oman Cables can also supply a range of alternative designs to meet customer specified requirements.

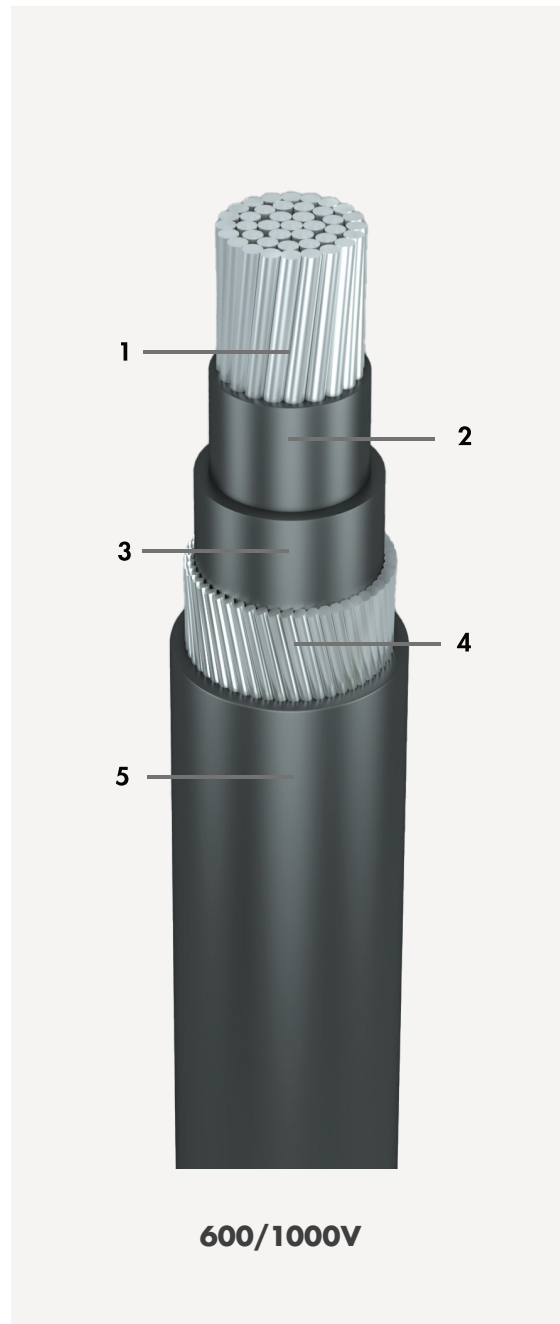

CORE COLOUR IDENTIFICATION

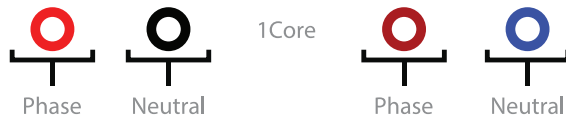

Note: Oman Cables has the capability to provide colour identification as per project requirements.

CHARACTERISTICS

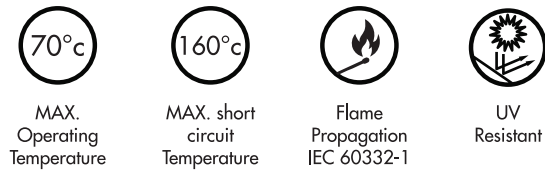

CABLE INSTALLATION

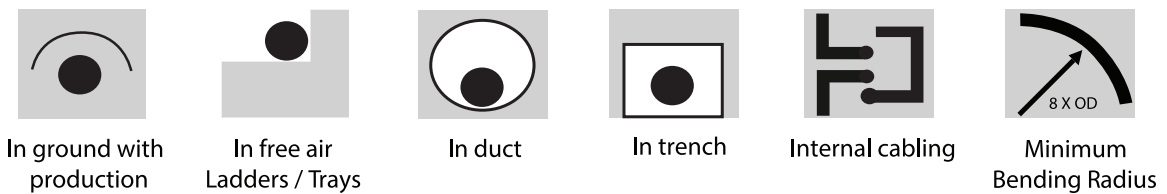

MULTI CORE

ALUMINUM CONDUCTOR, PVC (TYPE A) INSULATION, PVC BEDDING, GALVANIZED STEEL ROUND WIRE ARMoured & PVC SHEATH, LOW VOLTAGE POWER

APPLICATION

For outdoor installations in power stations, industrial plants and switchgears if mechanical protection is required or in applications where mechanical damages are expected to occur.

CONSTRUCTION

Stranded Aluminium Conductor, PVC (TYPE A) insulation, Non-hygroscopic Fillers & Binder tape (as required), Extruded PVC Bedding, Galvanized Steel Round Wire Armoured and Overall Extruded PVC Outer Sheath.

1. Conductor

Aluminium (Multi Stranded, Class-2)

2. Insulation

Extruded PVC (TYPE A)

3. Fillers & Binder Tape

Non-hygroscopic Fillers & binder tape

4. Bedding

Extruded PVC

5. Armour

Galvanized Steel Wire

6. Outer Sheath

Extruded Overall PVC Outer Sheath.

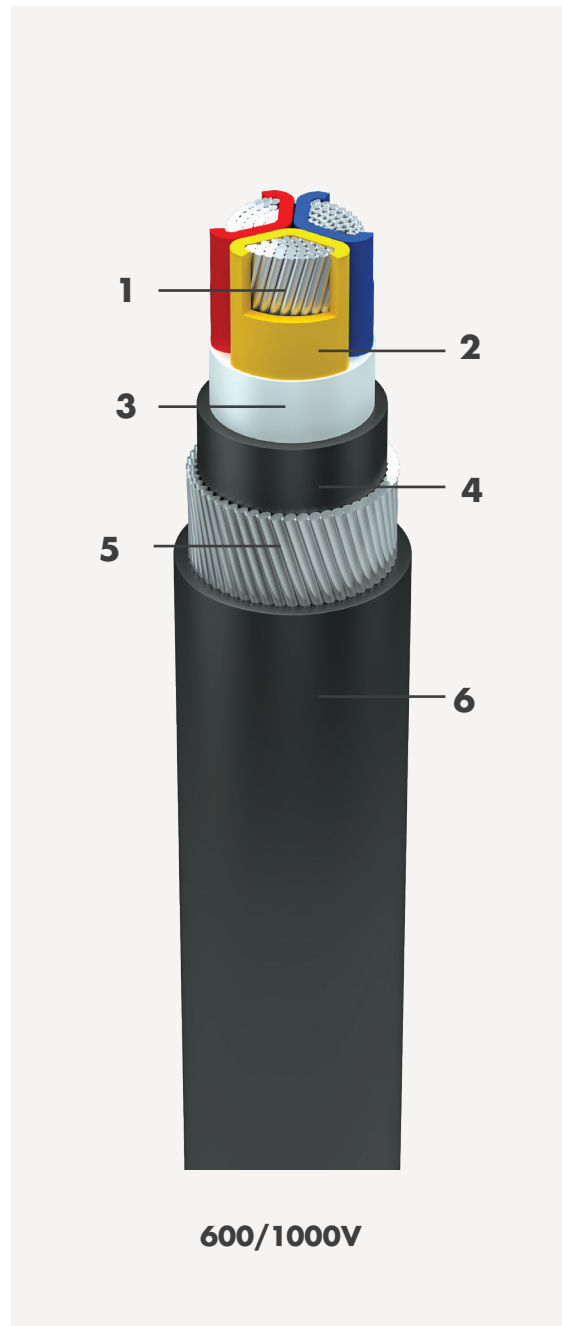

APPLICATION STANDARDS

Low Voltage Cables are designed and tested to meet the requirements of below standard:

- IEC 60502-1

Oman Cables can also supply a range of alternative designs to meet customer specified requirements.

CORE COLOUR IDENTIFICATION



Note: Oman Cables has the capability to provide colour identification as per project requirements.

CHARACTERISTICS

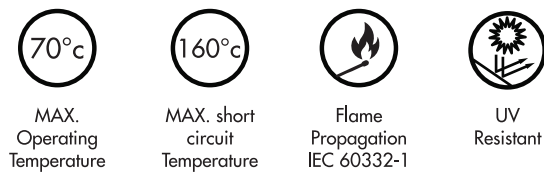

CABLE INSTALLATION

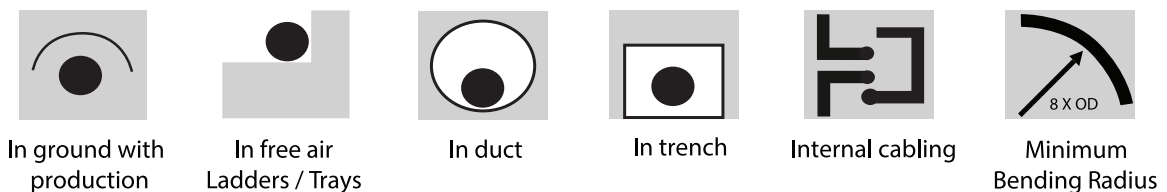

Cable size (mm ²)	Electrical Parameters						Current Rating *													
	DC Resistance (Ω/km)	AC Resistance (Approx.) (Ω/km)		Impedance (Approx.) (Ω/km) at 50Hz.		Voltage Drop (Approx.) (mV/A/m)			Ground at 35°C, (A)				Duct at 35°C, (A)				Air at 50°C, (A)			
		1 C	Multi-core	1 C	Multi-core	1 C	2 C	3/4/5 C	1 C	2 C	3/4 C	5 C	1 C	2 C	3/4 C	5 C	1 C	2 C	3/4 C	5 C
1.5	-	-	-	-	-	-	-	-	-	-	-	-	-	-	-	-	-	-	-	-
2.5	-	-	-	-	-	-	-	-	-	-	-	-	-	-	-	-	-	-	-	-
4	-	-	-	-	-	-	-	-	-	-	-	-	-	-	-	-	-	-	-	-
6	-	-	-	-	-	-	-	-	-	-	-	-	-	-	-	-	-	-	-	-
10	-	-	-	-	-	-	-	-	-	-	-	-	-	-	-	-	-	-	-	-
16	1.91	2.3	0.107	0.088	2.3	2.3	3.984	4.6	3.984	69	73	62	53	60	50	43	52	44	37	37
25	1.2	1.44	0.103	0.067	1.44	1.44	2.494	2.88	2.494	90	94	80	68	85	77	65	69	66	57	48
35	0.868	1.04	0.098	0.066	1.04	1.04	1.801	2.08	1.801	105	114	96	82	102	92	78	86	80	70	58
50	0.641	0.771	0.096	0.066	0.777	0.774	1.346	1.548	1.341	123	134	114	96	123	110	93	94	97	86	70
70	0.443	0.533	0.088	0.059	0.54	0.537	0.935	1.074	0.932	150	167	141	120	150	136	115	119	124	108	89
95	0.32	0.386	0.088	0.058	0.396	0.39	0.686	0.78	0.677	181	200	170	144	178	163	139	146	152	134	109
120	0.253	0.305	0.085	0.055	0.317	0.311	0.549	0.622	0.542	206	219	194	158	202	191	159	170	172	155	124
150	0.206	0.249	0.085	0.056	0.263	0.256	0.456	0.512	0.447	230	251	218	181	224	211	178	194	197	177	142
185	0.164	0.199	0.083	0.053	0.216	0.208	0.374	0.416	0.362	261	287	247	207	245	242	203	226	226	205	163
240	0.125	0.152	0.083	0.057	0.173	0.164	0.300	0.328	0.288	302	334	288	240	278	277	238	267	267	245	192
300	0.1	0.123	0.081	0.056	0.147	0.137	0.255	0.274	0.241	339	371	326	267	307	307	270	307	299	282	215
400	0.0778	0.097	0.08	0.055	0.126	0.114	0.218	0.228	0.199	389	402	353	289	335	351	295	364	344	308	248
500	0.0605	0.077	0.079	-	0.11	-	0.191	-	-	433	-	-	-	364	-	-	413	-	-	-
630	0.0469	0.062	0.077	-	0.099	-	0.171	-	-	479	-	-	-	394	-	-	467	-	-	-
800	0.0367	0.051	0.076	-	0.092	-	0.159	-	-	530	-	-	-	424	-	-	529	-	-	-
1000	0.0291	0.043	0.075	-	0.086	-	0.149	-	-	568	-	-	-	445	-	-	582	-	-	-

Physical Dimensions														
Approx. Cable OD, mm				Approx. Cable Weight, kg/km					Standard Drum Length, m					
1 C	2 C	3 C	4 C	5 C	1 C	2 C	3 C	4 C	5 C	1 C	2 C	3 C	4 C	5 C
-	-	-	-	-	-	-	-	-	-	-	-	-	-	-
-	-	-	-	-	-	-	-	-	-	-	-	-	-	-
-	-	-	-	-	-	-	-	-	-	-	-	-	-	-
-	-	-	-	-	-	-	-	-	-	-	-	-	-	-
-	-	-	-	-	-	-	-	-	-	-	-	-	-	-
13.0	21.5	22.5	25.0	27.0	205	695	805	1035	1151	1000	1000	1000	1000	1000
14.5	21.5	23.5	27.0	31.5	265	825	1015	1260	1520	1000	1000	1000	1000	500
15.5	23.5	26.0	29.5	35.0	315	960	1200	1475	1985	1000	1000	1000	1000	500
18.0	26.5	29.5	34.0	40.0	425	1165	1495	2025	2595	1000	1000	1000	500	500
19.5	30.0	33.5	37.5	44.5	515	1555	2030	2460	3215	1000	1000	500	500	500
22.0	33.5	37.5	43.0	51.5	655	1940	2520	3375	4455	1000	500	500	500	500
24.0	35.5	41.0	48.0	56.0	805	2210	2915	3995	5190	1000	500	500	500	500
26.0	40.0	46.5	52.5	61.5	940	2830	3750	4660	6110	1000	500	500	500	250
28.0	42.5	49.0	58.0	67.0	1125	3280	4365	5575	7215	1000	500	500	500	250
31.0	50.0	56.0	64.0	76.0	1385	4110	5395	6785	9550	500	500	500	250	250
34.5	54.5	62.0	70.0	84.0	1725	4845	6395	8010	11405	500	500	250	250	250
38.5	60.0	68.0	79.5	93.5	2115	5765	8205	10485	13745	500	500	250	250	250
42.0	65.5	74.0	85.5	-	2565	7395	9765	12395	-	500	250	250	250	-
46.0	71.5	81.0	94.0	-	3145	8745	11675	14945	-	500	250	250	250	-
51.5	-	-	-	-	3953	-	-	-	-	500	-	-	-	-
56.5	-	-	-	-	4795	-	-	-	-	500	-	-	-	-

Applicable standard: IEC 60502-1
Flame retardant property: IEC 60332-1

*Depth of laying in ground 0.5 Mtr.
Thermal resistivity of soil 1.2 K.m/W
1 Core cables are considered with Trefoil touching.

1.8/3.0 KV POWER CABLES UNARMoured

SINGLE CORE COPPER CONDUCTOR, XLPE INSULATION, COPPER TAPE SCREENED, UNARMoured & PVC SHEATH, POWER CABLE.

APPLICATION

For use indoors - in cable trenches or ducts; and outdoors - in power stations, industrial plants and switchgears if mechanical protection is not required, or in applications where the cable is not exposed to mechanical damage.

CONSTRUCTION

Multi-Stranded Annealed Plain Copper conductor, XLPE insulation, Extruded PVC Bedding, Copper Tape Metallic Screen and Overall Extruded PVC Outer Sheath.

1. Conductor

Annealed Plain Copper (Multi Stranded, Class-2)

2. Insulation

Extruded XLPE

3. Bedding

Extruded PVC

4. Metallic Screen

Copper Tape

5. Outer Sheath

Extruded Overall PVC Outer Sheath.

APPLICATION STANDARDS

Power Cables are designed and tested to meet the requirements of below standard:

- IEC 60502-1

Oman Cables can also supply a range of alternative designs to meet customer specified requirements.

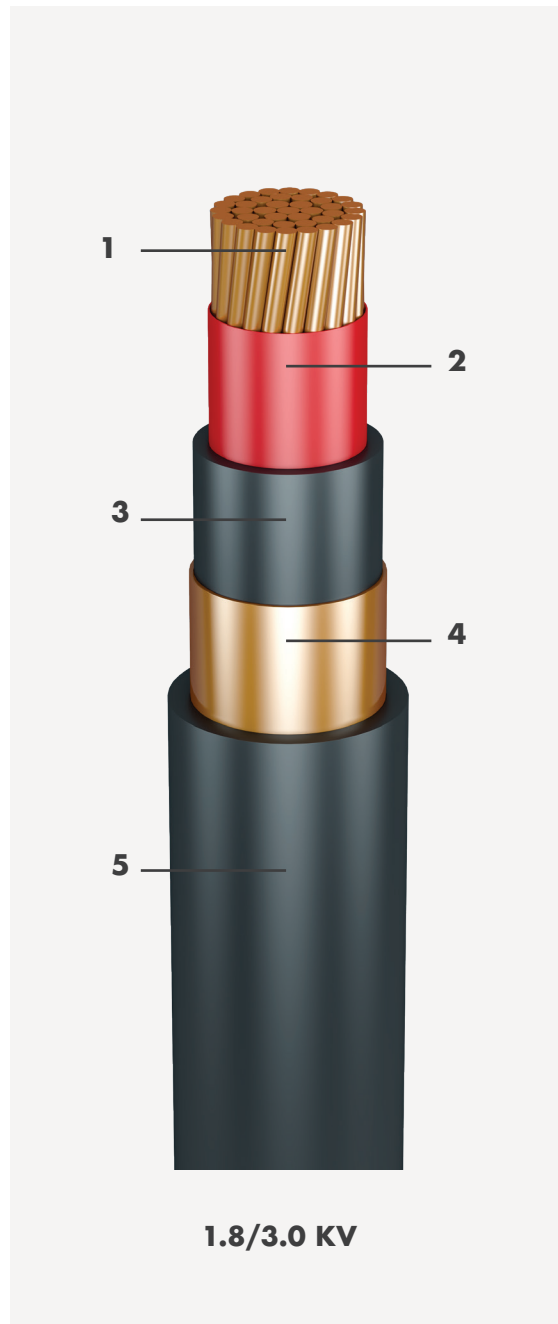

CORE COLOUR IDENTIFICATION

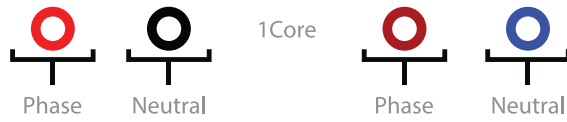

Note: Oman Cables has the capability to provide colour identification as per project requirements.

CHARACTERISTICS

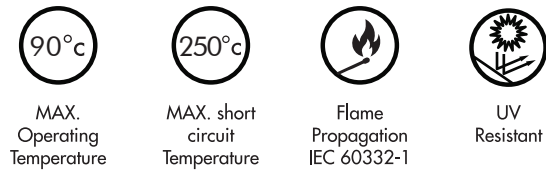

CABLE INSTALLATION

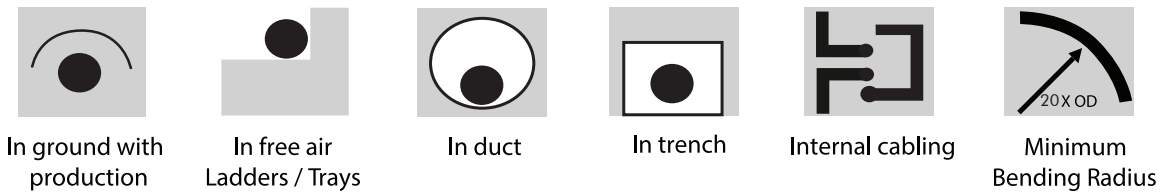

MULTI CORE COPPER CONDUCTOR, XLPE INSULATION, COPPER TAPE SCREENED, UNARMoured & PVC SHEATH, POWER CABLE.

APPLICATION

For use indoors - in cable trenches or ducts; and outdoors - in power stations, industrial plants and switchgears if mechanical protection is not required, or in applications where the cable is not exposed to mechanical damage.

CONSTRUCTION

Stranded Annealed Plain Copper Conductor, XLPE insulation, Non-hygroscopic Fillers & Binder tape (as required), Extruded PVC Bedding, Copper Tape Metallic Screen and Overall Extruded PVC Outer Sheath.

1. Conductor

Annealed Plain Copper (Multi Stranded, Class-2)

2. Insulation

XLPE

3. Fillers & Binder Tape

Non-hygroscopic Fillers & binder tape

4. Bedding

Extruded PVC

5. Metallic Screen

Copper Tape

6. Outer Sheath

Extruded Overall PVC Outer Sheath.

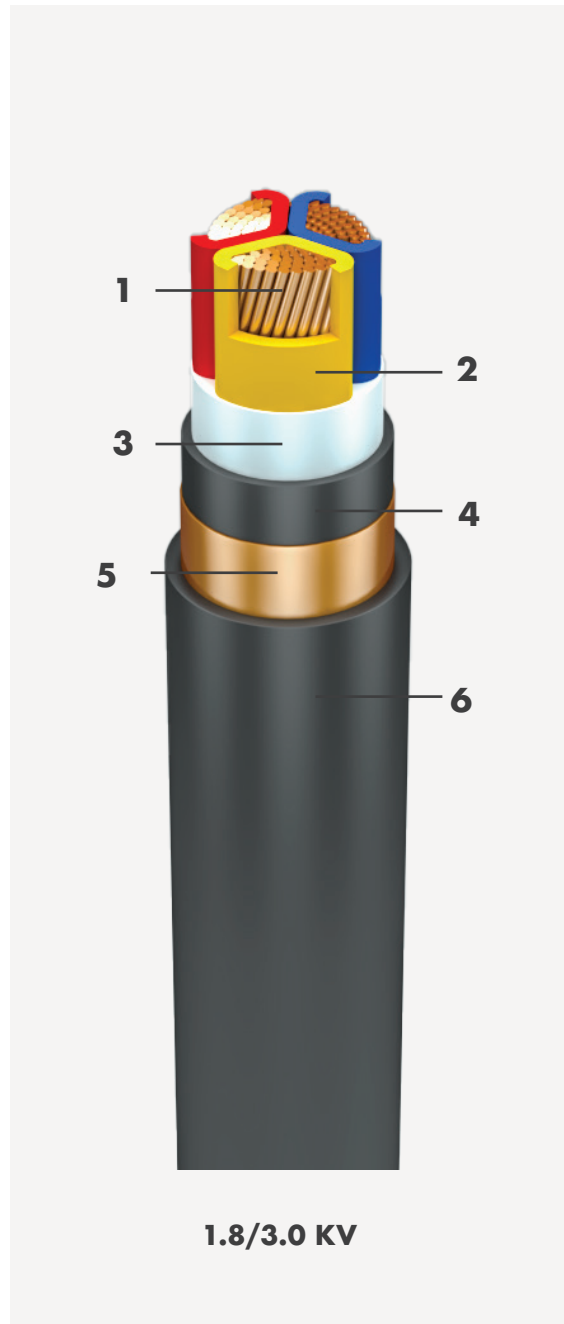

APPLICATION STANDARDS

Power Cables are designed and tested to meet the requirements of below standard:

- IEC 60502-1

Oman Cables can also supply a range of alternative designs to meet customer specified requirements.

CORE COLOUR IDENTIFICATION



Note: Oman Cables has the capability to provide colour identification as per project requirements.

CHARACTERISTICS

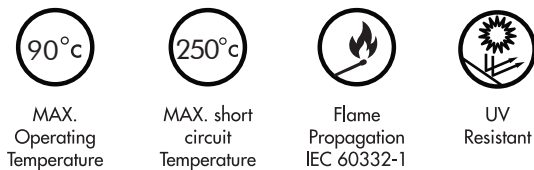

CABLE INSTALLATION

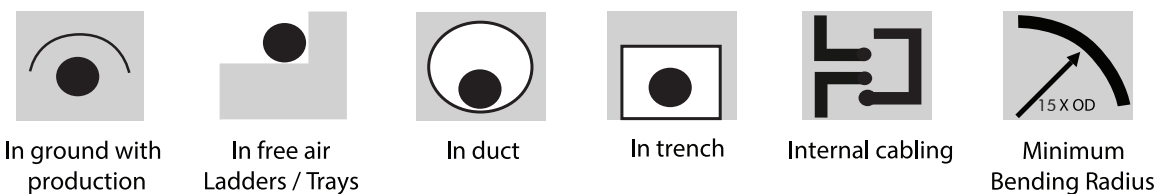

Cable size	Electrical Parameters						Current Rating *					
	DC Resistance (Ω/km)	AC Resistance (Ω/km)	Reactance (Approx.) at 50Hz. (Ω/km)	Impedance (Approx.) at 50Hz. (Ω/km)	Impedance (Approx.) at 50Hz. (Ω/km)	Voltage Drop (Approx.) ($\text{mV}/\text{A}/\text{m}$)	Ground at 35°C, (A)		Duct at 35°C, (A)		Air at 50°C, (A)	
(mm^2)	1 C	3 C	1 C	3 C	1 C	3 C	1 C	3 C	1 C	3 C	1 C	3 C
16	1.15	1.47	0.126	0.105	1.48	1.47	2.960	-	-	-	92	83
25	0.727	0.928	0.12	0.099	0.936	0.933	1.872	-	-	-	123	105
35	0.524	0.669	0.115	0.093	0.679	0.675	1.358	-	-	-	146	129
50	0.387	0.494	0.108	0.09	0.506	0.502	1.012	-	-	-	174	157
70	0.268	0.343	0.102	0.083	0.358	0.353	0.716	-	-	-	222	200
95	0.193	0.247	0.096	0.081	0.265	0.261	0.530	-	-	-	275	246
120	0.153	0.197	0.093	0.079	0.218	0.212	0.436	-	-	-	321	288
150	0.124	0.16	0.091	0.077	0.184	0.178	0.368	-	-	-	371	330
185	0.0991	0.129	0.089	0.075	0.157	0.149	0.314	-	-	-	430	381
240	0.0754	0.099	0.085	0.073	0.13	0.124	0.260	-	-	-	513	454
300	0.0601	0.08	0.083	0.072	0.115	0.109	0.230	-	-	-	594	524
400	0.047	0.065	0.082	0.071	0.105	0.097	0.210	-	-	-	692	608
500	0.0366	0.052	0.08	-	0.095	-	0.190	-	-	-	801	-
630	0.0283	0.043	0.079	-	0.09	-	0.180	-	-	-	925	-
800	0.0221	0.036	0.078	-	0.086	-	0.172	-	-	-	1051	-
1000	0.0176	0.032	0.077	-	0.083	-	0.166	-	-	-	1172	-

Physical Dimensions					
Approx. Cable OD, mm		Approx. Cable Weight, kg/km		Standard Drum Length, m	
1 C	3 C	1 C	3 C	1 C	3 C
13.0	24.5	295	885	1000	1000
14.5	27.0	395	1210	1000	1000
15.5	26.5	495	1395	1000	1000
16.5	29.5	620	1800	1000	1000
18.5	32.5	830	2430	1000	500
20.0	35.5	1095	3230	1000	500
21.5	39.0	1340	4000	1000	500
23.0	42.0	1610	4830	1000	500
25.0	44.0	1960	5865	1000	500
27.0	50.0	2510	7590	1000	500
29.5	55.0	3095	9375	1000	500
33.0	58.5	3905	11830	500	500
36.5	-	4960	-	500	-
41.0	-	6350	-	500	-
46.0	-	8105	-	500	-
50.5	-	10095	-	500	-

Applicable standard: IEC 60502-1
 Flame retardant property: IEC 60332-1

*Unarmoured cables are not recommended for underground installation.
 The shape of the conductor shall be Sector Shaped from size 35mm² and above.

SINGLE CORE ALUMINIUM CONDUCTOR, XLPE INSULATION, COPPER TAPE SCREENED, UNARMOURED & PVC SHEATH, POWER CABLE.

APPLICATION

For use indoors - in cable trenches or ducts; and outdoors - in power stations, industrial plants and switchgears if mechanical protection is not required, or in applications where the cable is not exposed to mechanical damage.

CONSTRUCTION

Multi-Stranded Aluminium conductor, XLPE insulation, Extruded PVC Bedding, Copper Tape Metallic Screen and Overall Extruded PVC Outer Sheath.

1. Conductor

Aluminium (Multi Stranded, Class-2)

2. Insulation

Extruded XLPE

3. Bedding

Extruded PVC

4. Metallic Screen

Copper Tape

5. Outer Sheath

Extruded Overall PVC Outer Sheath.

APPLICATION STANDARDS

Power Cables are designed and tested to meet the requirements of below standard:

- IEC 60502-1

Oman Cables can also supply a range of alternative designs to meet customer specified requirements.

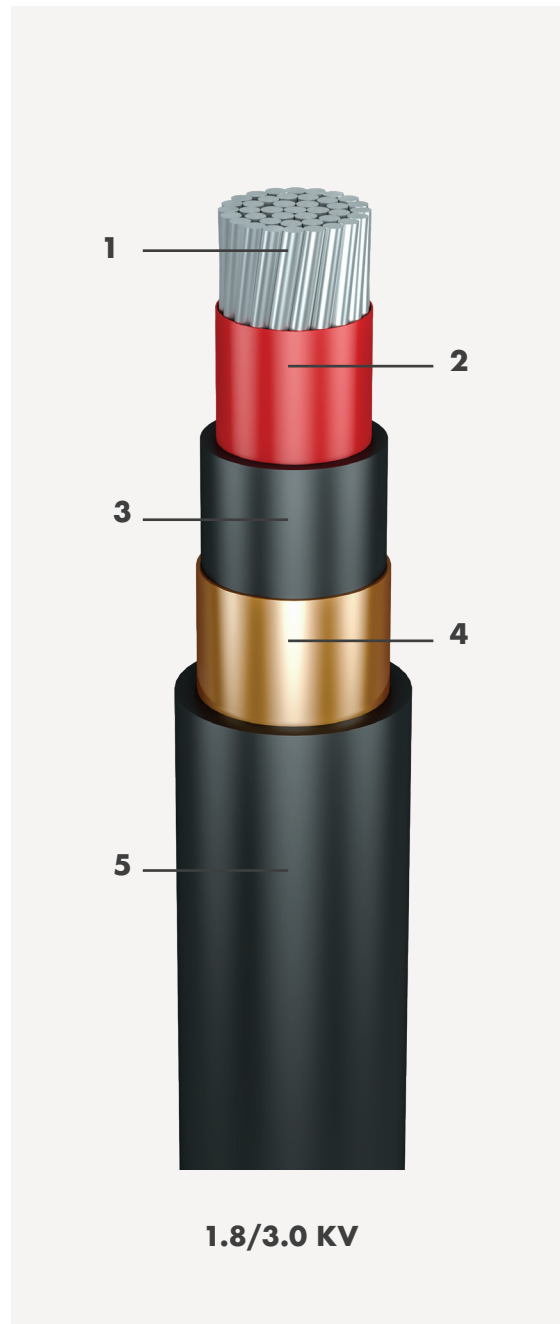

CORE COLOUR IDENTIFICATION

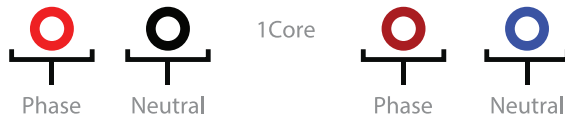

Note: Oman Cables has the capability to provide colour identification as per project requirements.

CHARACTERISTICS

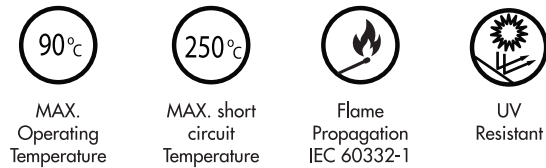

CABLE INSTALLATION

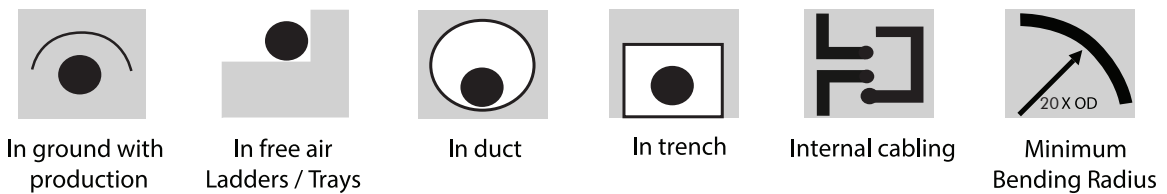

MULTI CORE

ALUMINIUM CONDUCTOR, XLPE INSULATION, COPPER TAPE SCREENED, UNARMOURED & PVC SHEATH, POWER CABLE.

APPLICATION

For use indoors - in cable trenches or ducts; and outdoors - in power stations, industrial plants and switchgears if mechanical protection is not required, or in applications where the cable is not exposed to mechanical damage.

CONSTRUCTION

Stranded Aluminium, XLPE insulation, Non-hygroscopic Fillers & Binder tape (as required), Extruded PVC Bedding, Copper Tape Metallic Screen and Overall Extruded PVC Outer Sheath.

1. Conductor

Aluminium (Multi Stranded, Class-2)

2. Insulation

XLPE

3. Fillers & Binder Tape

Non-hygroscopic Fillers & binder tape

4. Bedding

Extruded PVC

5. Metallic Screen

Copper Tape

6. Outer Sheath

Extruded Overall PVC Outer Sheath.

APPLICATION STANDARDS

Power Cables are designed and tested to meet the requirements of below standard:

- IEC 60502-1

Oman Cables can also supply a range of alternative designs to meet customer specified requirements.

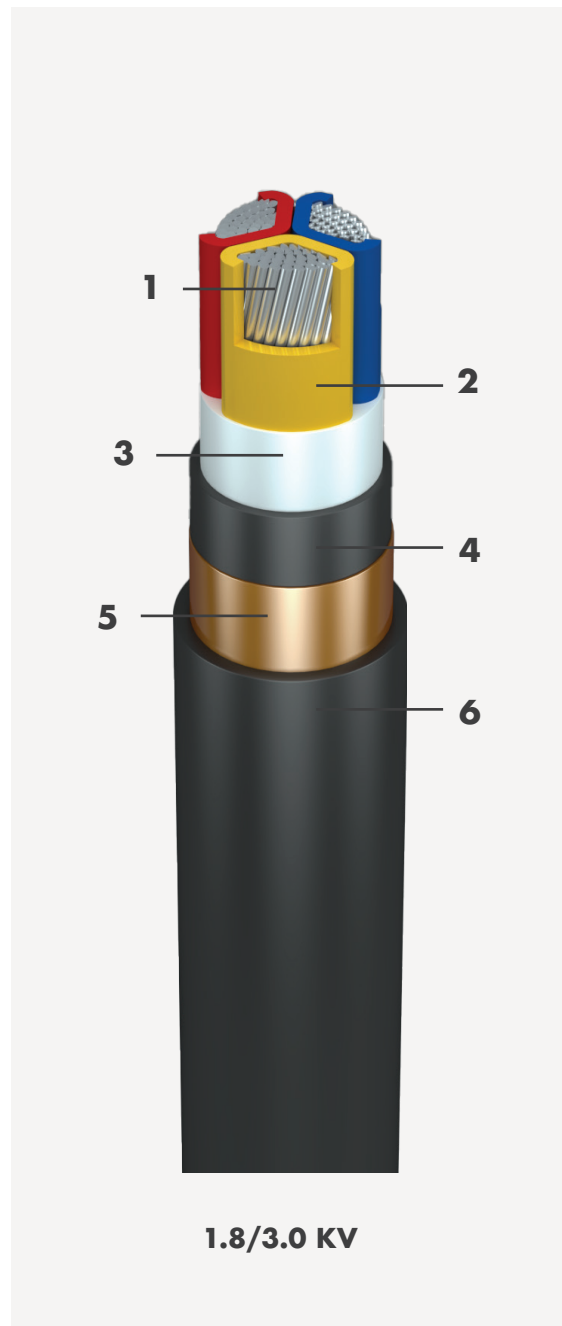

CORE COLOUR IDENTIFICATION



Note: Oman Cables has the capability to provide colour identification as per project requirements.

CHARACTERISTICS

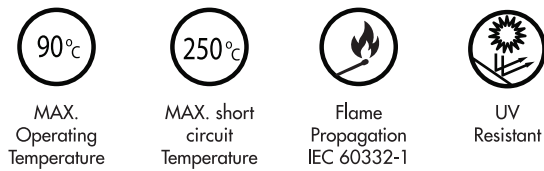

CABLE INSTALLATION

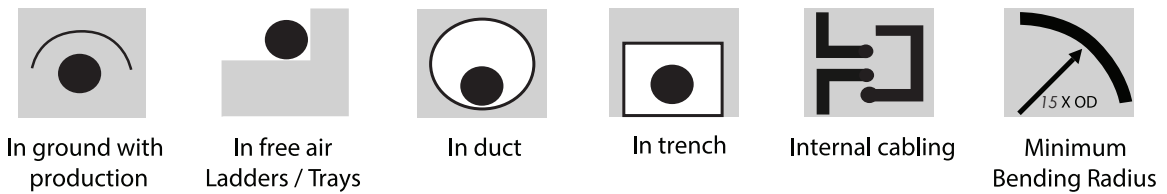

Cable size	Electrical Parameters						Current Rating *					
	DC Resistance (Ω/km)	AC Resistance (Ω/km)	Reactance (Approx.) at 50Hz. (Ω/km)	Impedance (Approx. prox.) at 50Hz. (Ω/km)	Impedance (Approx. prox.) at 50Hz. (Ω/km)	Voltage Drop (Approx.) (mV/A/m)	Ground at 35°C, (A)		Duct at 35°C, (A)		Air at 50°C, (A)	
(mm ²)	1 C	3C	1 C	3C	1 C	3C	1 C	3 C	1 C	3 C	1 C	3 C
16	1.91	2.45	0.126	0.105	2.45	2.45	4.900	-	-	-	72	63
25	1.2	1.54	0.12	0.099	1.54	1.54	3.080	-	-	-	94	79
35	0.868	1.11	0.115	0.093	1.12	1.11	2.240	-	-	-	118	97
50	0.641	0.823	0.108	0.09	0.83	0.828	1.660	-	-	-	129	118
70	0.443	0.569	0.102	0.083	0.578	0.575	1.156	-	-	-	165	150
95	0.32	0.411	0.096	0.081	0.422	0.42	0.844	-	-	-	204	185
120	0.253	0.326	0.093	0.079	0.339	0.335	0.678	-	-	-	237	216
150	0.206	0.265	0.091	0.077	0.28	0.277	0.560	-	-	-	274	247
185	0.164	0.212	0.089	0.075	0.23	0.225	0.460	-	-	-	319	287
240	0.125	0.162	0.085	0.073	0.183	0.179	0.366	-	-	-	381	342
300	0.1	0.131	0.083	0.072	0.155	0.149	0.310	-	-	-	442	395
400	0.0778	0.103	0.082	0.071	0.132	0.126	0.264	-	-	-	535	420
500	0.0605	0.081	0.08	-	0.114	-	0.228	-	-	-	619	-
630	0.0469	0.065	0.079	-	0.102	-	0.204	-	-	-	713	-
800	0.0367	0.053	0.078	-	0.094	-	0.188	-	-	-	833	-
1000	0.0291	0.044	0.077	-	0.089	-	0.178	-	-	-	956	-

Physical Dimensions					
Approx. Cable OD, mm		Approx. Cable Weight, kg/km		Standard Drum Length, m	
1 C	3 C	1 C	3 C	1 C	3 C
13.0	24.5	200	600	1000	1000
14.5	27.0	240	750	1000	1000
15.5	26.5	285	755	1000	1000
16.5	29.5	335	940	1000	1000
18.5	32.5	425	1185	1000	500
20.0	35.5	525	1500	1000	500
21.5	39.0	615	1810	1000	500
23.0	42.0	720	2110	1000	500
25.0	44.0	845	2490	1000	500
27.0	50.0	1045	3165	1000	500
29.5	55.0	1250	3785	1000	500
33.0	58.5	1560	4625	500	500
36.5	-	1925	-	500	-
41.0	-	2440	-	500	-
46.0	-	3065	-	500	-
50.5	-	3780	-	500	-

Applicable standard: IEC 60502-1
 Flame retardant property: IEC 60332-1

*Unarmoured cables are not recommended for underground installation.
 The shape of the conductor shall be Sector Shaped from size 35mm² and above.

SINGLE CORE COPPER CONDUCTOR, PVC (TYPE A) INSULATION, COPPER TAPE SCREENED, UNARMoured & PVC SHEATH, POWER CABLE.

APPLICATION

For use indoors - in cable trenches or ducts; and outdoors - in power stations, industrial plants and switchgears if mechanical protection is not required, or in applications where the cable is not exposed to mechanical damage.

CONSTRUCTION

Multi-Stranded Annealed Plain Copper conductor, PVC (TYPE A) insulation, Extruded PVC Bedding, Copper Tape Metallic Screen and Overall Extruded PVC Outer Sheath.

1. Conductor

Annealed Plain Copper (Multi Stranded, Class-2)

2. Insulation

Extruded PVC (TYPE A)

3. Bedding

Extruded PVC

4. Metallic Screen

Copper Tape

5. Outer Sheath

Extruded Overall PVC Outer Sheath.

APPLICATION STANDARDS

Power Cables are designed and tested to meet the requirements of below standard:

- IEC 60502-1

Oman Cables can also supply a range of alternative designs to meet customer specified requirements.

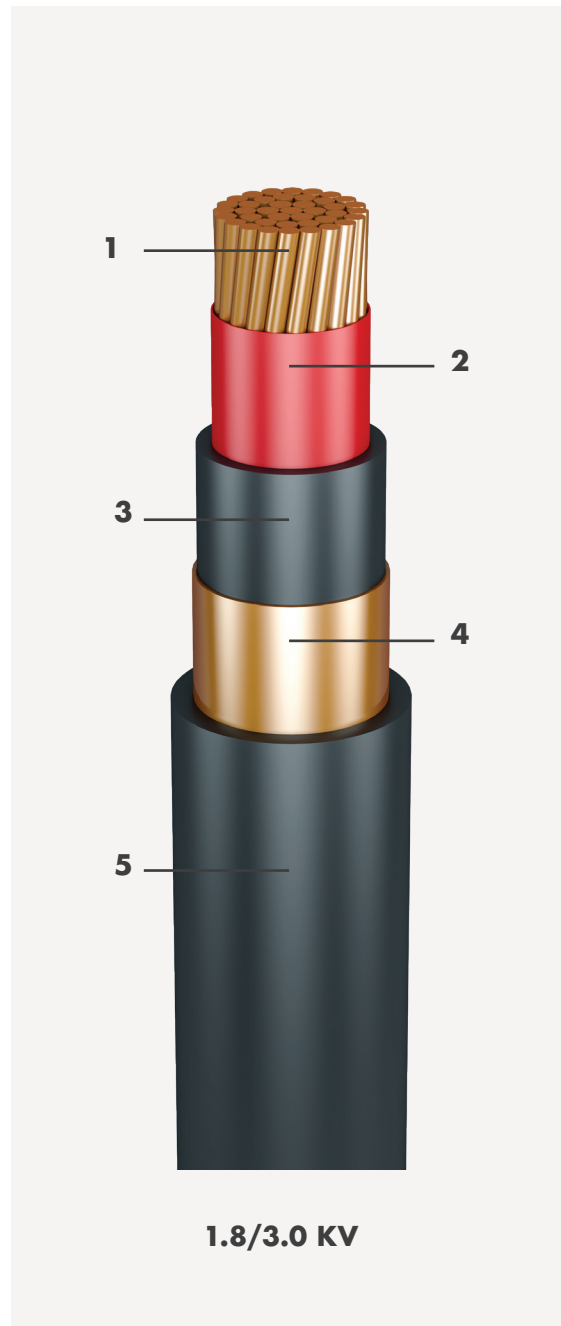

CORE COLOUR IDENTIFICATION

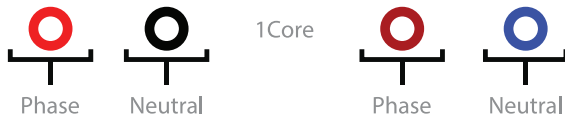

Note: Oman Cables has the capability to provide colour identification as per project requirements.

CHARACTERISTICS

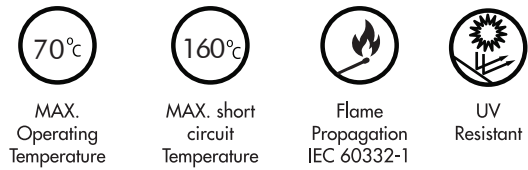

CABLE INSTALLATION

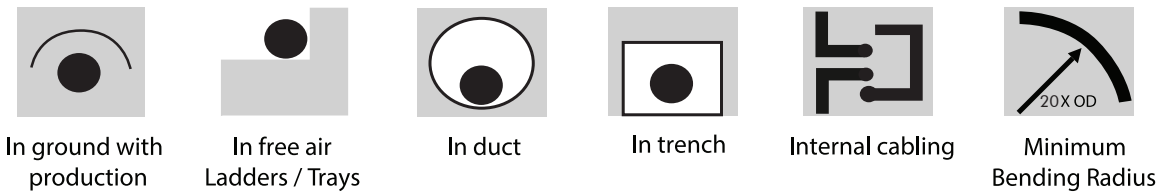

MULTI CORE COPPER CONDUCTOR, PVC (TYPE A) INSULATION, COPPER TAPE SCREENED, UNARMoured & PVC SHEATH, POWER CABLE.

APPLICATION

For use indoors - in cable trenches or ducts; and outdoors - in power stations, industrial plants and switchgears if mechanical protection is not required, or in applications where the cable is not exposed to mechanical damage.

CONSTRUCTION

Stranded Annealed Plain Copper Conductor, PVC (TYPE A) insulation, Non-hygroscopic Fillers & Binder tape (as required), Extruded PVC Bedding, Copper Tape Metallic Screen and Overall Extruded PVC Outer Sheath.

1. Conductor

Annealed Plain Copper (Multi Stranded, Class-2)

2. Insulation

Extruded PVC (TYPE A)

3. Fillers & Binder Tape

Non-hygroscopic Fillers & binder tape

4. Bedding

Extruded PVC

5. Metallic Screen

Copper Tape

6. Outer Sheath

Extruded Overall PVC Outer Sheath.

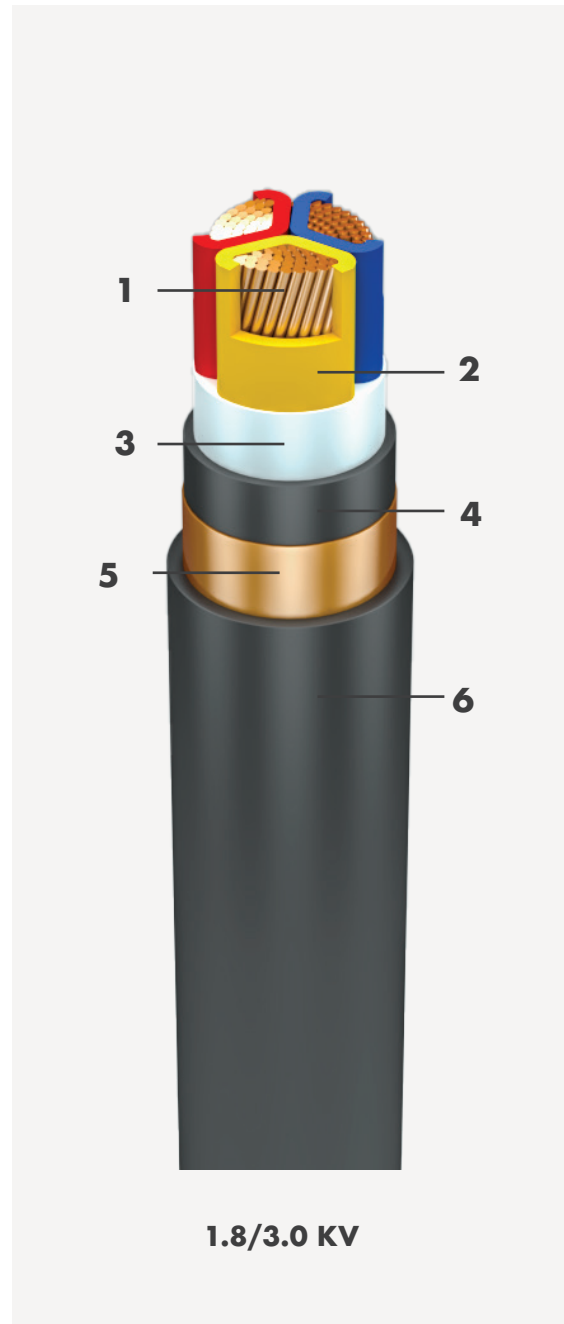

APPLICATION STANDARDS

Power Cables are designed and tested to meet the requirements of below standard:

- IEC 60502-1

Oman Cables can also supply a range of alternative designs to meet customer specified requirements.

CORE COLOUR IDENTIFICATION



Note: Oman Cables has the capability to provide colour identification as per project requirements.

CHARACTERISTICS

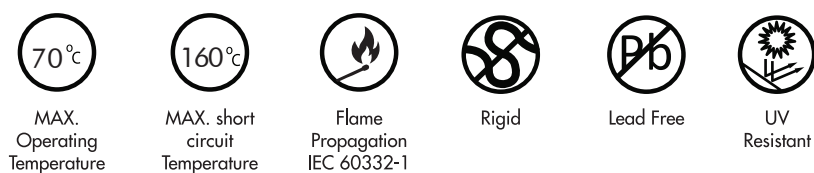

CABLE INSTALLATION

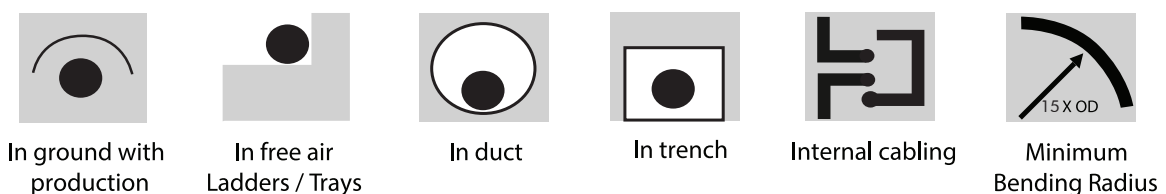

Cable size (mm ²)	Electrical Parameters						Current Rating *							
	DC Resis- tance (Ω /km)	AC Resis- tance (Ω /km)	Reactance (Approx.) at 50Hz. (Ω /km)			Impedance (Approx.) at 50Hz. (Ω /km)			Voltage Drop (Approx.) (mV/A/m)			Air at 50°C, (A)		
			1 C	3C	3C	1 C	3C	3C	1 C	3C	1 C	3C		
1.5	-	-	-	-	-	-	-	-	-	-	-	-	-	-
2.5	-	-	-	-	-	-	-	-	-	-	-	-	-	-
4	-	-	-	-	-	-	-	-	-	-	-	-	-	-
6	-	-	-	-	-	-	-	-	-	-	-	-	-	-
10	-	-	-	-	-	-	-	-	-	-	-	-	-	-
16	1.1500	1.380	0.129	0.107	1.39	1.380	2.78	2.39	67	56				
25	0.7270	0.870	0.120	0.102	0.878	0.877	1.76	1.52	90	74				
35	0.5240	0.628	0.115	0.095	0.638	0.635	1.28	1.10	107	91				
50	0.3870	0.464	0.110	0.092	0.477	0.473	0.95	0.82	123	111				
70	0.2680	0.322	0.102	0.085	0.338	0.333	0.68	0.58	156	141				
95	0.1930	0.232	0.098	0.082	0.252	0.247	0.50	0.43	194	174				
120	0.1530	0.185	0.094	0.08	0.208	0.202	0.42	0.35	226	202				
150	0.1240	0.150	0.092	0.079	0.176	0.170	0.35	0.29	260	231				
185	0.0991	0.121	0.089	0.076	0.15	0.144	0.30	0.25	302	267				
240	0.0754	0.093	0.086	0.074	0.127	0.120	0.25	0.21	360	318				
300	0.0601	0.076	0.085	0.074	0.114	0.107	0.23	0.19	415	365				
400	0.0470	0.061	0.083	0.073	0.103	0.096	0.21	0.17	484	423				
500	0.0366	0.050	0.082	-	0.096	-	0.19	-	557	-				
630	0.0283	0.041	0.080	-	0.09	-	0.18	-	641	-				
800	0.0221	0.035	0.078	-	0.085	-	0.17	-	726	-				
1000	0.0176	0.031	0.078	-	0.084	-	0.17	-	808	-				

Physical Dimensions					
Approx. Cable OD, mm		Approx. Cable Weight, kg/km		Standard Drum Length, m	
1 C	3 C	1 C	3 C	1 C	3 C
-	-	-	-	-	-
-	-	-	-	-	-
-	-	-	-	-	-
-	-	-	-	-	-
-	-	-	-	-	-
13.5	25.0	330	995	1000	1000
14.5	28.0	435	1330	1000	1000
15.5	27.5	540	1550	1000	1000
17.0	30.5	675	1975	1000	500
18.5	33.5	885	2630	1000	500
20.5	36.5	1165	3445	1000	500
22.0	40.0	1410	4235	1000	500
23.5	43.0	1690	5090	1000	500
25.0	45.0	2045	6150	1000	500
27.5	51.0	2610	7910	1000	500
30.5	57.0	3230	9835	500	500
34.0	61.0	4090	12425	500	250
37.5	-	5170	-	500	-
41.5	-	6560	-	500	-
46.0	-	8315	-	500	-
51.0	-	10340	-	500	-

Applicable standard: IEC 60502-1
 Flame retardant property: IEC 60332-1

*Unarmoured cables are not recommended for underground installation.
 The shape of the conductor shall be Sector Shaped from size 35mm² and above.

SINGLE CORE

SINGLE CORE ALUMINIUM CONDUCTOR, PVC (TYPE A) INSULATION, COPPER TAPE SCREENED, UNARMOURED & PVC SHEATH, POWER CABLE.

APPLICATION

For outdoor installations in power stations, industrial plants and switchgears if mechanical protection is required or in applications where mechanical damages are expected to occur.

CONSTRUCTION

Multi-Stranded Annealed Plain Aluminum conductor, PVC (TYPE A), Extruded PVC Bedding, Copper tape metallic screen and Overall Extruded PVC Outer Sheath.

1. Conductor

Annealed Plain Aluminum (Multi Stranded, Class-2)

2. Insulation

Extruded PVC (TYPE A)

3. Bedding

Extruded PVC

4. Metallic Screen

Copper Tape

5. Outer Sheath

Extruded Overall PVC Outer Sheath.

APPLICATION STANDARDS

Power Cables are designed and tested to meet the requirements of below standard:

- IEC 60502-1

Oman Cables can also supply a range of alternative designs to meet customer specified requirements.

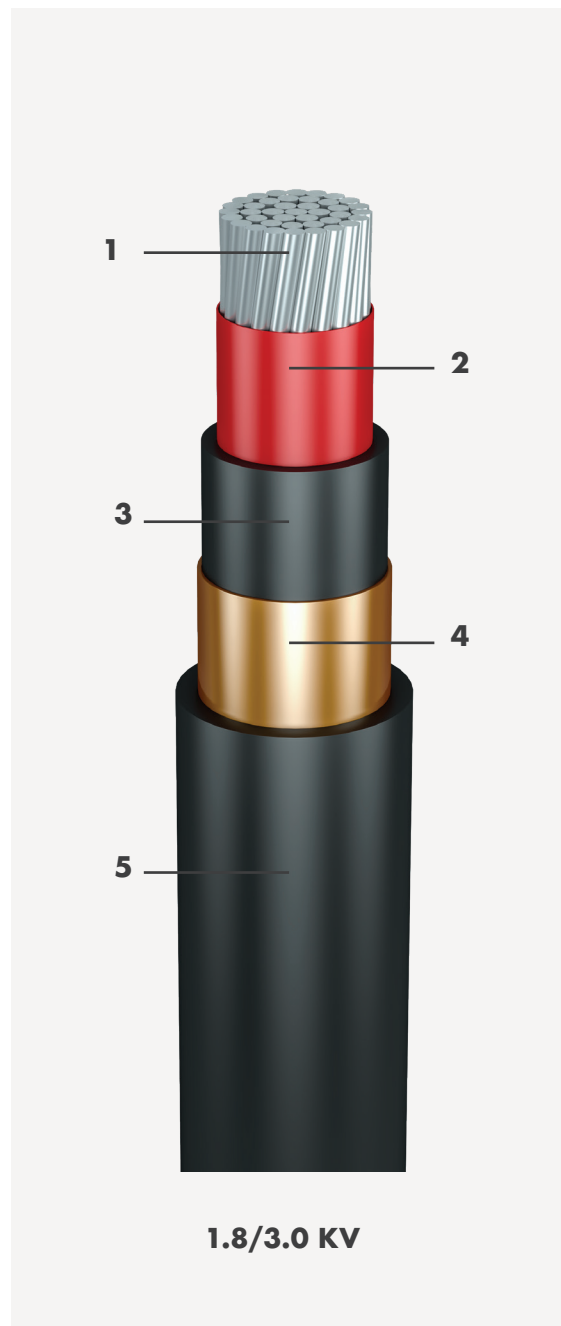

CORE COLOUR IDENTIFICATION

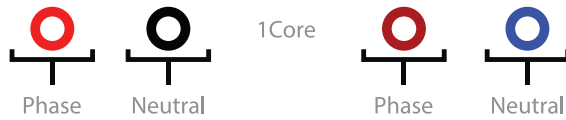

Note: Oman Cables has the capability to provide colour identification as per project requirements.

CHARACTERISTICS

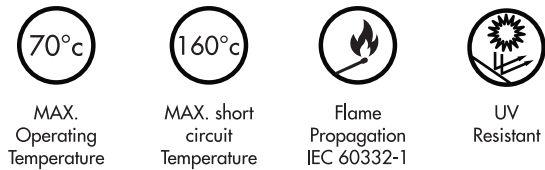

CABLE INSTALLATION

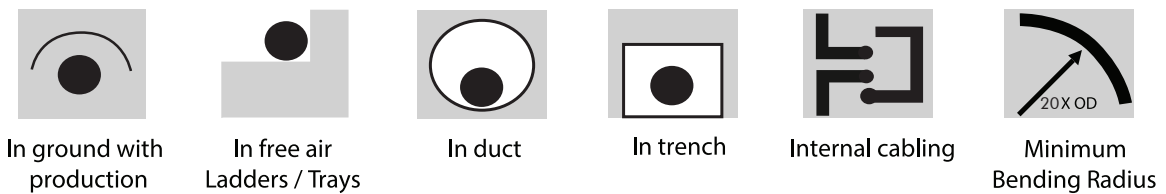

MULTI CORE

MULTI CORE ALUMINIUM CONDUCTOR, PVC (TYPE A) INSULATION, COPPER TAPE SCREENED, UNARMOURED & PVC SHEATH, POWER CABLE.

APPLICATION

For outdoor installations in power stations, industrial plants and switchgears if mechanical protection is required or in applications where mechanical damages are expected to occur.

CONSTRUCTION

Stranded Annealed Plain Aluminum Conductor, PVC (TYPE A), Non-hygroscopic Fillers & Binder tape (as required), Extruded PVC Bedding, Copper tape metallic screen and Overall Extruded PVC Outer Sheath.

1. Conductor

Annealed Plain Aluminum (Multi Stranded, Class-2)

2. Insulation

Extruded PVC (TYPE A)

3. Fillers & Binder Tape

Non-hygroscopic Fillers & binder tape

4. Bedding

Extruded PVC

5. Metallic Screen:

Copper Tape

6. Outer Sheath

Extruded Overall PVC Outer Sheath.

APPLICATION STANDARDS

Power Cables are designed and tested to meet the requirements of below standard:

- IEC 60502-1

Oman Cables can also supply a range of alternative designs to meet customer specified requirements.

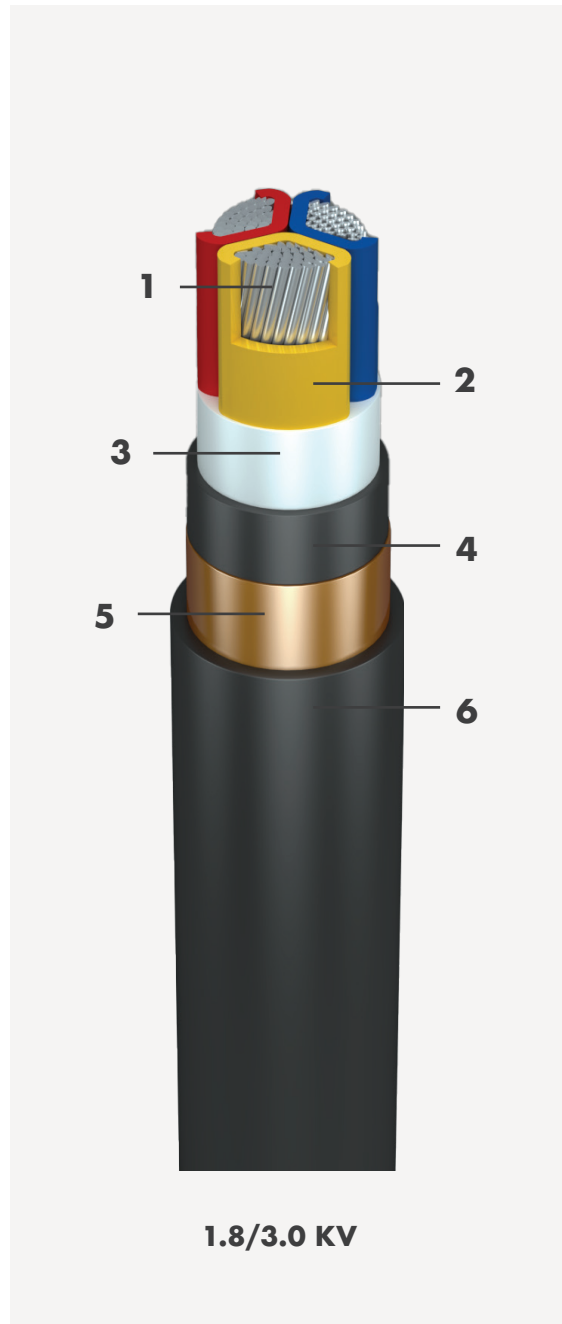

CORE COLOUR IDENTIFICATION

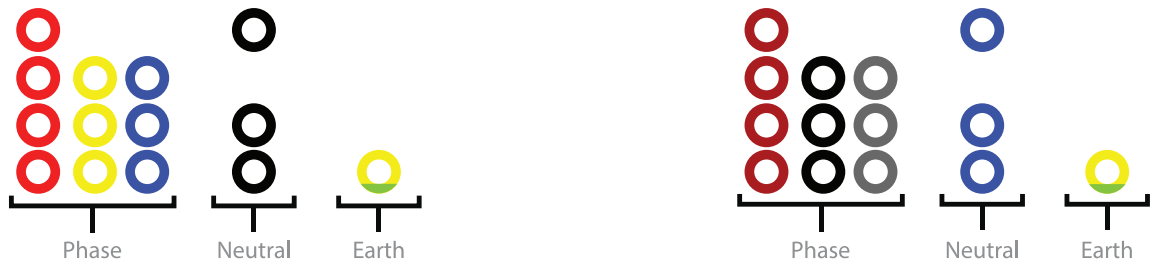

Note: Oman Cables has the capability to provide colour identification as per project requirements.

CHARACTERISTICS

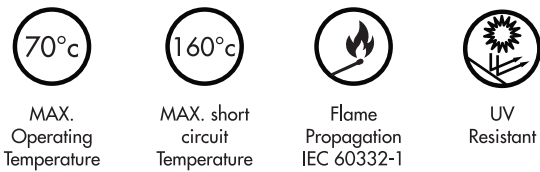

CABLE INSTALLATION

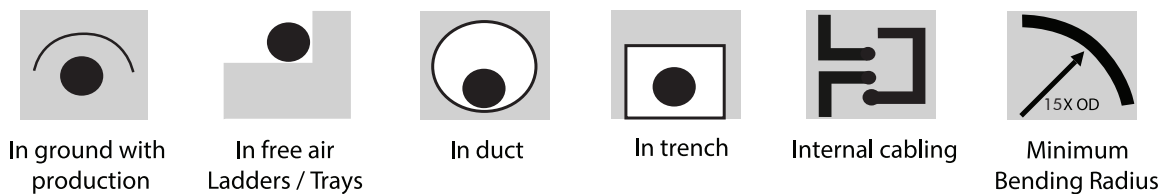

Cable size (mm ²)	Electrical Parameters						Current Rating *					
	DC Resis- tance (Ω/km)	AC Resis- tance (Ω/km)	Reactance (Approx.) at 50Hz. (Ω/km)	Impedance (Approx.) at 50Hz. (Ω/km)	Voltage Drop (Approx.) (mV/A/m)		Air at 50°C, (A)					
	1 C	3C	1 C	3C	1 C	3C	1 C	3 C				
1.5	-	-	-	-	-	-	-	-	-			
2.5	-	-	-	-	-	-	-	-	-			
4	-	-	-	-	-	-	-	-	-			
6	-	-	-	-	-	-	-	-	-			
10	-	-	-	-	-	-	-	-	-			
16	1.910	2.300	0.129	0.107	2.300	2.300	4.60	52	42			
25	1.200	1.440	0.120	0.102	1.440	1.440	2.88	69	56			
35	0.868	1.040	0.115	0.095	1.050	1.040	2.10	86	68			
50	0.641	0.771	0.110	0.092	0.779	0.776	1.56	92	83			
70	0.443	0.533	0.102	0.085	0.543	0.540	1.09	117	106			
95	0.320	0.386	0.098	0.082	0.398	0.395	0.80	144	131			
120	0.253	0.305	0.094	0.080	0.319	0.315	0.64	168	151			
150	0.206	0.249	0.092	0.079	0.265	0.261	0.53	193	174			
185	0.164	0.199	0.089	0.076	0.218	0.213	0.44	224	200			
240	0.125	0.152	0.086	0.074	0.175	0.170	0.35	268	239			
300	0.100	0.123	0.085	0.074	0.150	0.144	0.30	311	276			
400	0.0778	0.097	0.083	0.073	0.128	0.122	0.26	375	308			
500	0.0605	0.077	0.082	-	0.112	-	0.22	431	-			
630	0.0469	0.061	0.080	-	0.101	-	0.20	496	-			
800	0.0367	0.050	0.078	-	0.093	-	0.19	579	-			
1000	0.0291	0.042	0.078	-	0.089	-	0.18	663	-			

Physical Dimensions					
Approx. Cable OD, mm		Approx. Cable Weight, kg/km		Standard Drum Length, m	
1 C	3 C	1 C	3 C	1 C	3 C
-	-	-	-	-	-
-	-	-	-	-	-
-	-	-	-	-	-
-	-	-	-	-	-
-	-	-	-	-	-
13.5	25.0	235	705	1000	1000
14.5	28.0	285	875	1000	1000
15.5	27.5	330	910	1000	1000
17.0	30.5	395	1115	1000	500
18.5	33.5	480	1385	1000	500
20.5	36.5	595	1715	1000	500
22.0	40.0	690	2050	1000	500
23.5	43.0	795	2370	1000	500
25.0	45.0	935	2775	1000	500
27.5	51.0	1140	3485	1000	500
30.5	57.0	1385	4250	500	500
34.0	61.0	1740	5220	500	250
37.5	-	2140	-	500	-
41.5	-	2650	-	500	-
46.0	-	3275	-	500	-
51.0	-	4030	-	500	-

Applicable standard: IEC 60502-1
 Flame retardant property: IEC 60332-1

*Unarmoured cables are not recommended for underground installation.
 The shape of the conductor shall be Sector Shaped from size 35mm² and above.

1.8/3.0 KV POWER CABLES ARMOURED

SINGLE CORE COPPER CONDUCTOR, XLPE INSULATION, PVC BEDDING, ALUMINIUM WIRE ARMoured & PVC SHEATH, POWER CABLE.

APPLICATION

For outdoor installations in power stations, industrial plants and switchgears if mechanical protection is required or in applications where mechanical damages are expected to occur.

CONSTRUCTION

Multi-Stranded Annealed Plain Copper conductor, XLPE insulation, Extruded PVC Bedding, Aluminium Round Wire Armour and Overall Extruded PVC Outer Sheath.

1. Conductor

Annealed Plain Copper (Multi Stranded, Class-2)

2. Insulation

XLPE

3. Bedding

Extruded PVC

4. Armour

Aluminium Round Wire

5. Outer Sheath

Extruded Overall PVC Outer Sheath.

APPLICATION STANDARDS

Power Cables are designed and tested to meet the requirements of below standard:

- IEC 60502-1

Oman Cables can also supply a range of alternative designs to meet customer specified requirements.

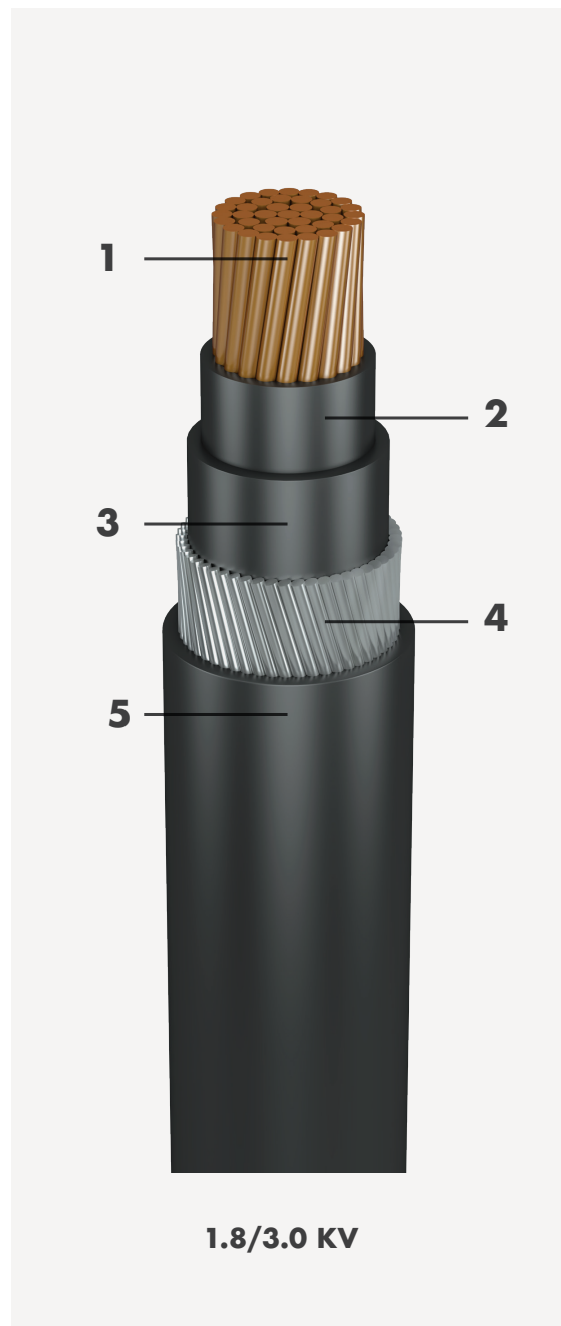

CORE COLOUR IDENTIFICATION

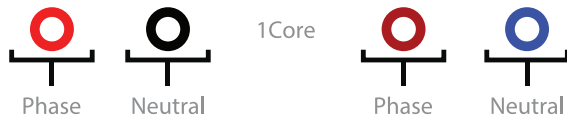

Note: Oman Cables has the capability to provide colour identification as per project requirements.

CHARACTERISTICS

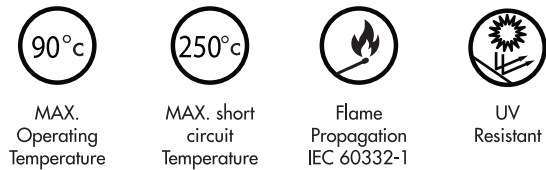

CABLE INSTALLATION

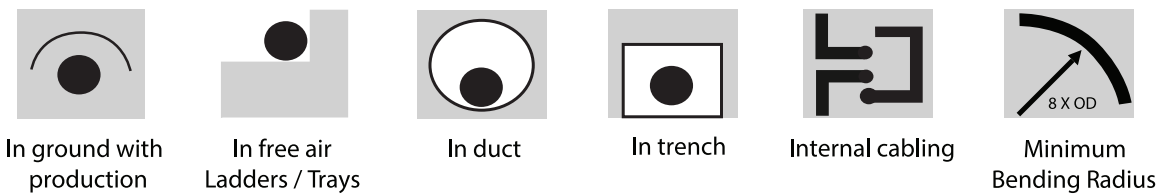

MULTI CORE COPPER CONDUCTOR, XLPE INSULATION, PVC BEDDING, GALVANIZED STEEL ROUND WIRE ARMOURED & PVC SHEATH, POWER CABLE.

APPLICATION

For outdoor installations in power stations, industrial plants and switchgears if mechanical protection is required or in applications where mechanical damages are expected to occur.

CONSTRUCTION

Stranded Annealed Plain Copper Conductor, XLPE insulation, Non-hygroscopic Fillers & Binder tape (as required), Extruded PVC Bedding, Galvanized Steel Round Wire Armoured and Overall Extruded PVC Outer Sheath.

1. Conductor

Annealed Plain Copper (Multi Stranded, Class-2)

2. Insulation

XLPE

3. Fillers & Binder Tape

Non-hygroscopic Fillers & binder tape

4. Bedding

Extruded PVC

5. Armour

Galvanized Steel Wire

6. Outer Sheath

Extruded Overall PVC Outer Sheath.

APPLICATION STANDARDS

Power Cables are designed and tested to meet the requirements of below standard:

- IEC 60502-1

Oman Cables can also supply a range of alternative designs to meet customer specified requirements.

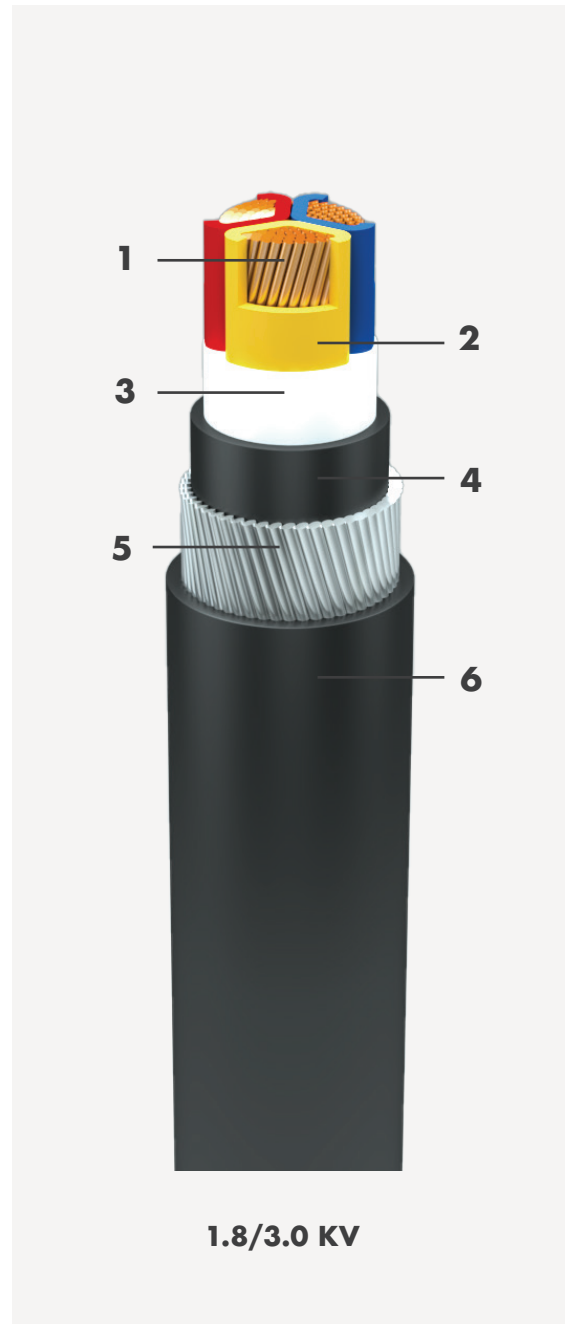

CORE COLOUR IDENTIFICATION

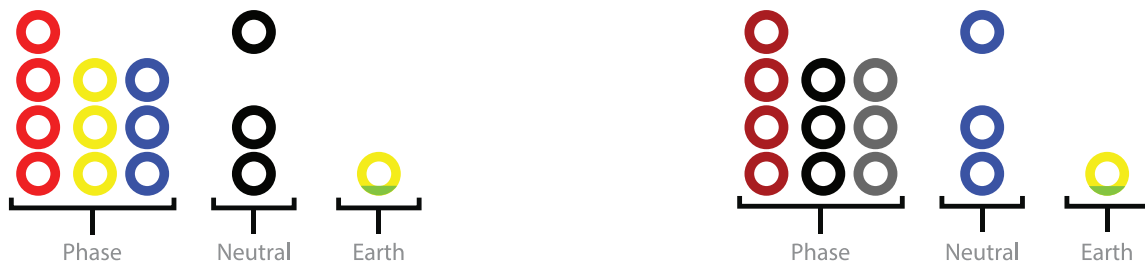

Note: Oman Cables has the capability to provide colour identification as per project requirements.

CHARACTERISTICS

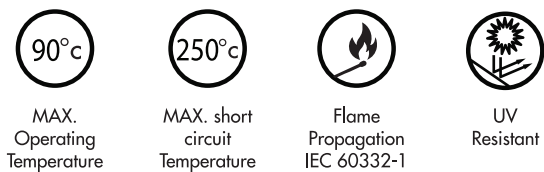

CABLE INSTALLATION

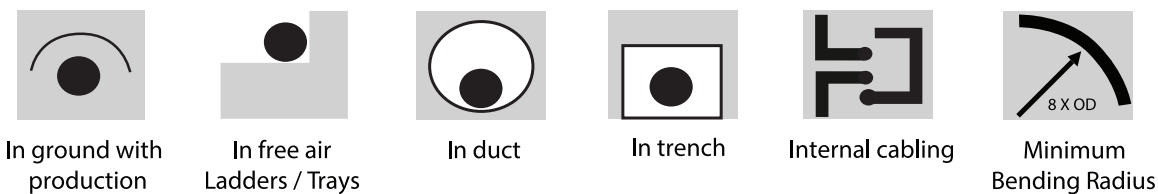

Cable size (mm ²)	Electrical Parameters						Current Rating *					
	DC Resis- tance (Ω/km)	AC Resis- tance (Ω/km)	Reactance (Approx.) at 50Hz. (Ω/km)	Impedance (Approx.) at 50Hz. (Ω/km)	Voltage Drop (Approx.) (mV/A/m)		Ground at 35°C, (A)		Air at 50°C, (A)			
	1 C	3C	1 C	3C	1 C	3C	1 C	3 C	1 C	3 C	1 C	3 C
16	1.150	1.470	0.133	0.104	1.480	1.470	2.563	2.546	100	98	87	87
25	0.727	0.928	0.130	0.098	0.937	0.933	1.623	1.616	130	126	118	116
35	0.524	0.669	0.124	0.092	0.680	0.675	1.178	1.169	155	151	141	138
50	0.387	0.495	0.117	0.089	0.508	0.502	0.880	0.869	191	178	187	166
70	0.268	0.343	0.109	0.083	0.360	0.353	0.624	0.611	233	218	234	209
95	0.193	0.248	0.106	0.080	0.269	0.261	0.466	0.452	279	261	287	256
120	0.153	0.197	0.103	0.078	0.221	0.212	0.383	0.367	315	297	334	296
150	0.124	0.161	0.100	0.077	0.189	0.178	0.327	0.308	352	333	380	337
185	0.099	0.130	0.096	0.074	0.160	0.149	0.277	0.258	396	375	434	387
240	0.075	0.100	0.093	0.073	0.136	0.124	0.236	0.215	454	432	512	455
300	0.060	0.082	0.090	0.072	0.120	0.109	0.208	0.189	507	484	583	520
400	0.047	0.066	0.089	0.070	0.110	0.096	0.191	0.166	560	544	664	597
500	0.037	0.054	0.087		0.101		0.175	0.152	619		751	
630	0.028	0.045	0.085		0.095		0.165	0.144	679		846	
800	0.022	0.035	0.085		0.092		0.159		715		919	
1000	0.018	0.031	0.084		0.090		0.156		757		997	

Physical Dimensions					
Approx. Cable OD, mm		Approx. Cable Weight, kg/km		Standard Drum Length, m	
1 C	3 C	1 C	3 C	1 C	3 C
14.5	27.5	336	1408	1000	1000
17.0	30.0	476	1799	1000	1000
18.0	29.5	582	1969	1000	1000
19.0	33.5	712	1324	1000	500
21.0	36.5	931	1676	1000	500
23.5	39.5	1252	2117	1000	500
25.0	44.0	1502	2695	1000	500
26.5	47.0	1789	3169	1000	500
28.0	49.0	2148	3734	1000	500
30.5	55.0	1361	4683	500	500
33.0	60.0	1660	5679	500	500
37.0	63.5	2117	3487	500	250
40.5		2660		500	
45.0		3375		500	
51.0		4356		500	
56.0		5377		500	

Applicable standard: IEC 60502-1
 Flame retardant property: IEC 60332-1

*Unarmoured cables are not recommended for underground installation.
 The shape of the conductor shall be Sector Shaped from size 35mm² and above.

SINGLE CORE ALUMINIUM CONDUCTOR, XLPE INSULATION, PVC BEDDING, ALUMINIUM WIRE ARMoured & PVC SHEATH, POWER CABLE.

APPLICATION

For outdoor installations in power stations, industrial plants and switchgears if mechanical protection is required or in applications where mechanical damages are expected to occur.

CONSTRUCTION

Multi-Stranded Aluminium conductor, XLPE insulation, Extruded PVC Bedding, Aluminium Round Wire Armour and Overall Extruded PVC Outer Sheath.

1. Conductor

Aluminium (Multi Stranded, Class-2)

2. Insulation

XLPE

3. Bedding

Extruded PVC

4. Armour

Aluminium Round Wire

5. Outer Sheath

Extruded Overall PVC Outer Sheath.

APPLICATION STANDARDS

Power Cables are designed and tested to meet the requirements of below standard:

- IEC 60502-1

Oman Cables can also supply a range of alternative designs to meet customer specified requirements.

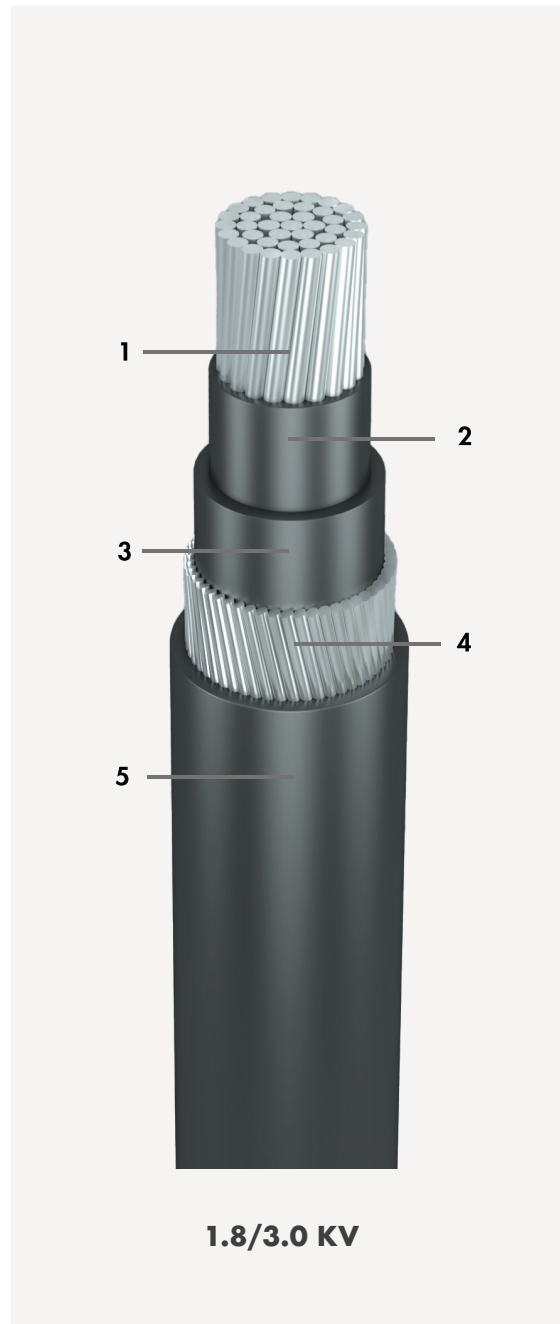

CORE COLOUR IDENTIFICATION

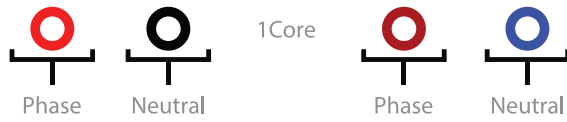

Note: Oman Cables has the capability to provide colour identification as per project requirements.

CHARACTERISTICS

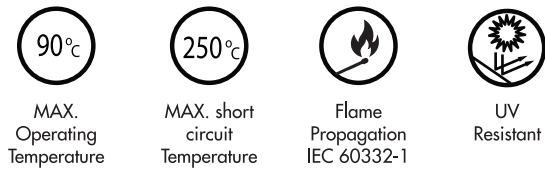

CABLE INSTALLATION

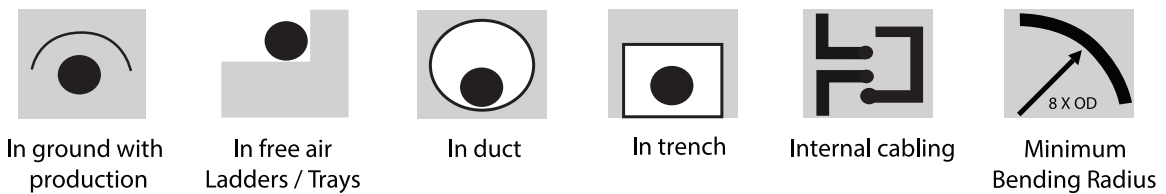

MULTI CORE

ALUMINIUM CONDUCTOR, XLPE INSULATION, PVC BEDDING, GALVANIZED STEEL ROUND WIRE ARMoured & PVC SHEATH, POWER CABLE.

APPLICATION

For outdoor installations in power stations, industrial plants and switchgears if mechanical protection is required or in applications where mechanical damages are expected to occur.

CONSTRUCTION

Stranded Aluminium Conductor, XLPE insulation, Non-hygroscopic Fillers & Binder tape (as required), Extruded PVC Bedding, Galvanized Steel Round Wire Armoured and Overall Extruded PVC Outer Sheath.

1. Conductor

Aluminium (Multi Stranded, Class-2)

2. Insulation

XLPE

3. Fillers & Binder Tape

Non-hygroscopic Fillers & binder tape

4. Bedding

Extruded PVC

5. Armour

Galvanized Steel Wire

6. Outer Sheath

Extruded Overall PVC Outer Sheath.

APPLICATION STANDARDS

Power Cables are designed and tested to meet the requirements of below standard:

- IEC 60502-1

Oman Cables can also supply a range of alternative designs to meet customer specified requirements.

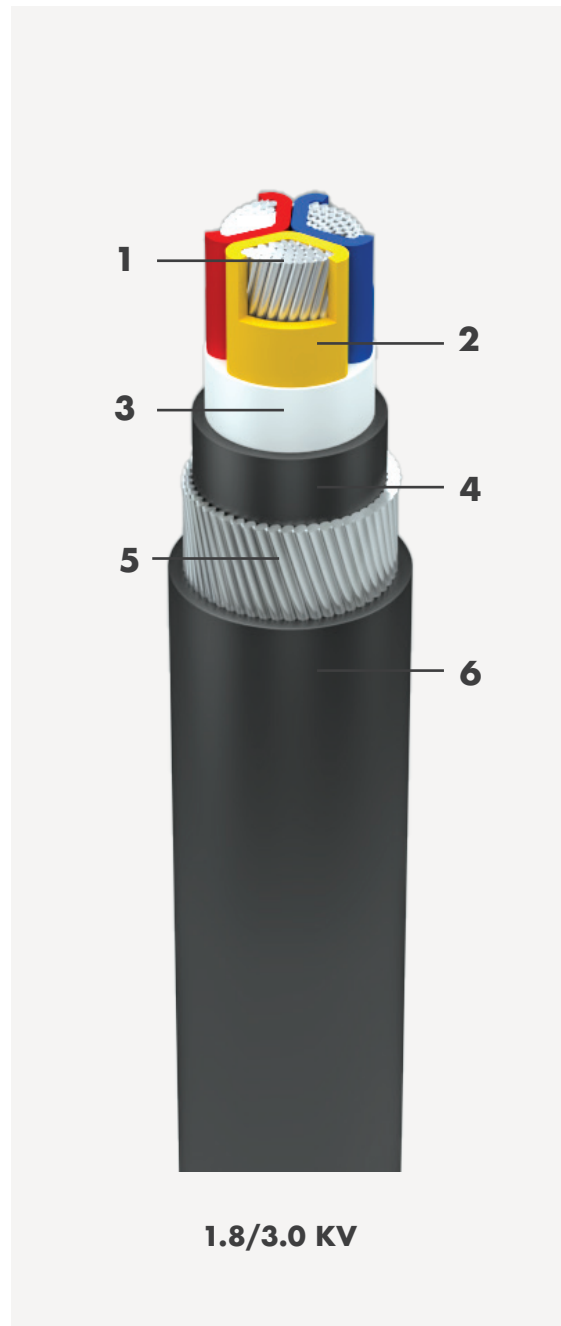

CORE COLOUR IDENTIFICATION



Note: Oman Cables has the capability to provide colour identification as per project requirements.

CHARACTERISTICS

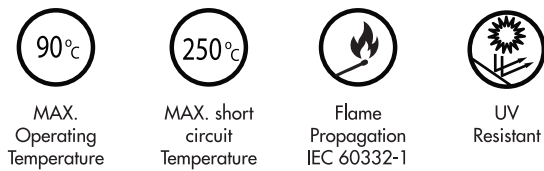

CABLE INSTALLATION

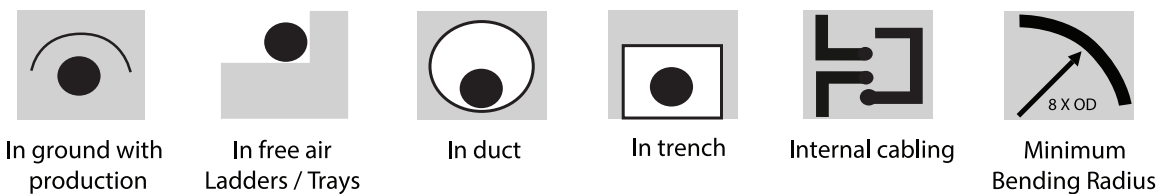

Cable size (mm ²)	Electrical Parameters						Current Rating *					
	DC Resis- tance (Ω/km)	AC Resis- tance (Ω/km)	Reactance (Approx.) at 50Hz. (Ω/km)		Impedance (Approx.) at 50Hz. (Ω/km)		Voltage Drop (Approx.) (mV/A/m)		Ground at 35°C, (A)		Air at 50°C, (A)	
			1 C	3C	1 C	3C	1 C	3C	1 C	3 C	1 C	3 C
16	1.910	2.450	0.133	0.104	2.450	2.450	4.244	4.244	76	75	67	66
25	1.200	1.540	0.130	0.098	1.550	1.540	2.685	2.667	101	97	89	87
35	0.868	1.110	0.124	0.092	1.120	1.110	1.940	1.923	118	115	113	104
50	0.641	0.823	0.117	0.089	0.831	0.828	1.439	1.434	146	136	140	126
70	0.443	0.569	0.109	0.083	0.579	0.575	1.003	0.996	179	167	176	158
95	0.320	0.411	0.106	0.080	0.424	0.261	0.734	0.452	213	200	215	193
120	0.253	0.325	0.103	0.078	0.341	0.212	0.591	0.367	243	228	250	224
150	0.206	0.265	0.100	0.077	0.283	0.178	0.490	0.308	271	255	285	254
185	0.164	0.212	0.096	0.074	0.233	0.149	0.404	0.258	305	289	327	293
240	0.125	0.162	0.093	0.073	0.187	0.124	0.324	0.215	353	335	386	346
300	0.100	0.130	0.090	0.072	0.158	0.109	0.274	0.189	396	378	442	397
400	0.078	0.102	0.089	0.070	0.135	0.096	0.234	0.166	454	397	526	415
500	0.061	0.081	0.087		0.119		0.206		504		595	
630	0.047	0.064	0.085		0.106		0.184		555		672	
800	0.037	0.052	0.085		0.100		0.173		609		760	
1000	0.029	0.044	0.084		0.095		0.165		661		843	

Physical Dimensions					
Approx. Cable OD, mm		Approx. Cable Weight, kg/km		Standard Drum Length, m	
1 C	3 C	1 C	3 C	1 C	3 C
14.5	27.5	240	1120	1000	1000
17.0	30.0	325	1343	1000	1000
18.0	29.5	372	1330	1000	1000
19.0	33.5	430	893	1000	500
21.0	36.5	527	1053	1000	500
23.5	39.5	681	1253	1000	500
25.0	44.0	780	1602	1000	500
26.5	47.0	899	1809	1000	500
28.0	49.0	1037	2046	1000	500
30.5	55.0	627	2470	500	500
33.0	60.0	739	2886	500	500
37.0	63.5	944	1686	500	250
40.5		1144		500	
45.0		1420		500	
51.0		1835		500	
56.0		2221		500	

Applicable standard: IEC 60502-1
 Flame retardant property: IEC 60332-1

*Unarmoured cables are not recommended for underground installation.
 The shape of the conductor shall be Sector Shaped from size 35mm² and above.

SINGLE CORE COPPER CONDUCTOR, XLPE INSULATION, PVC BEDDING, ALUMINIUM WIRE ARMoured & PVC SHEATH, POWER CABLE.

APPLICATION

For outdoor installations in power stations, industrial plants and switchgears if mechanical protection is required or in applications where mechanical damages are expected to occur.

CONSTRUCTION

Multi-Stranded Annealed Plain Copper conductor, XLPE insulation, Extruded PVC Bedding, Aluminium Round Wire Armour and Overall Extruded PVC Outer Sheath.

1. Conductor

Annealed Plain Copper (Multi Stranded, Class-2)

2. Insulation

XLPE

3. Bedding

Extruded PVC

4. Armour

Aluminium Round Wire

5. Outer Sheath

Extruded Overall PVC Outer Sheath.

APPLICATION STANDARDS

Power Cables are designed and tested to meet the requirements of below standard:

- BS 5467

Oman Cables can also supply a range of alternative designs to meet customer specified requirements.

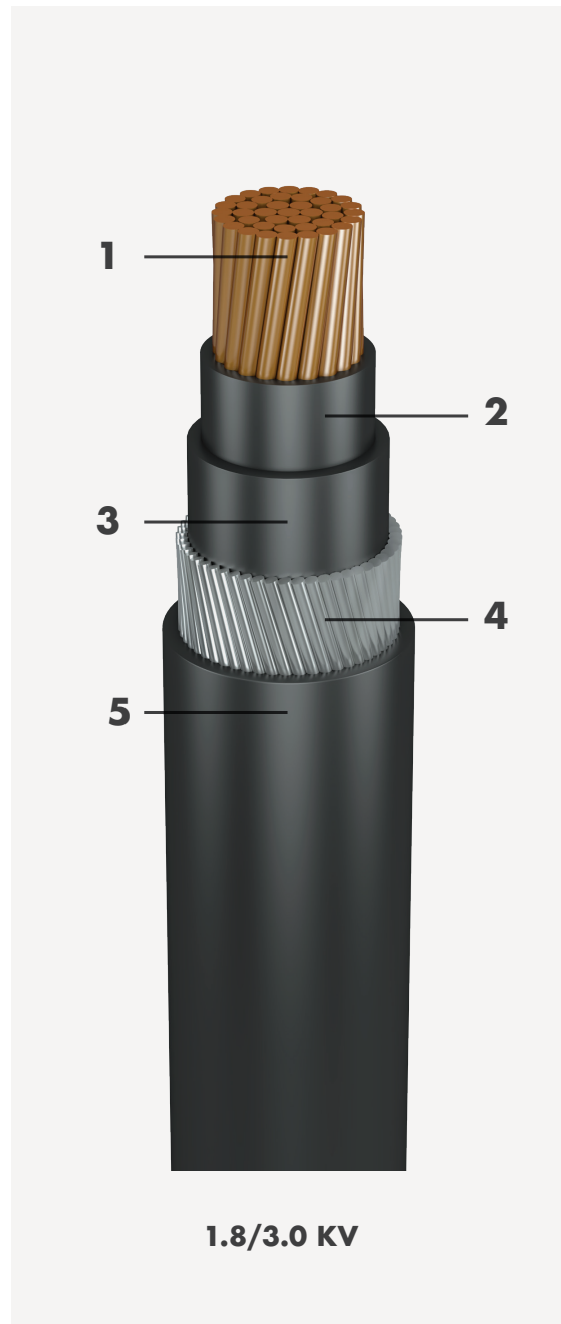

CORE COLOUR IDENTIFICATION

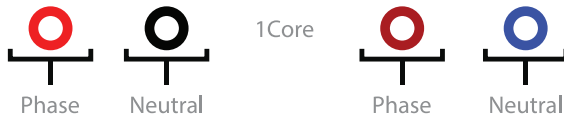

Note: Oman Cables has the capability to provide colour identification as per project requirements.

CHARACTERISTICS

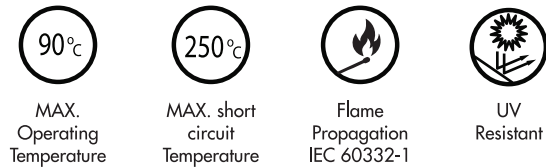

CABLE INSTALLATION

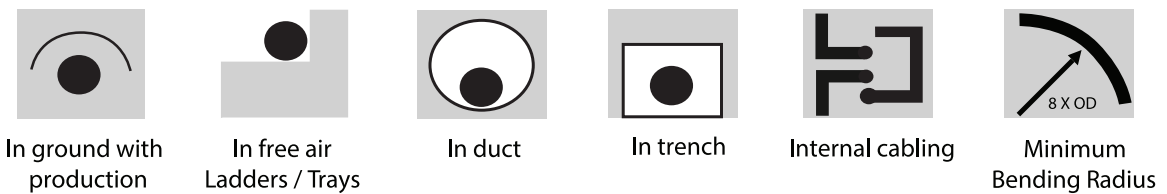

MULTI CORE

COPPER CONDUCTOR, XLPE INSULATION, PVC BEDDING, GALVANIZED STEEL ROUND WIRE ARMoured & PVC SHEATH, POWER CABLE.

APPLICATION

For outdoor installations in power stations, industrial plants and switchgears if mechanical protection is required or in applications where mechanical damages are expected to occur.

CONSTRUCTION

Stranded Annealed Plain Copper Conductor, XLPE insulation, Non-hygroscopic Fillers & Binder tape (as required), Extruded PVC Bedding, Galvanized Steel Round Wire Armoured and Overall Extruded PVC Outer Sheath

1. Conductor

Annealed Plain Copper (Multi Stranded, Class-2)

2. Insulation

XLPE

3. Fillers & Binder Tape

Non-hygroscopic Fillers & binder tape

5. Bedding

Extruded PVC

6. Armour

Galvanized Steel Wire

7. Outer Sheath

Extruded Overall PVC Outer Sheath.

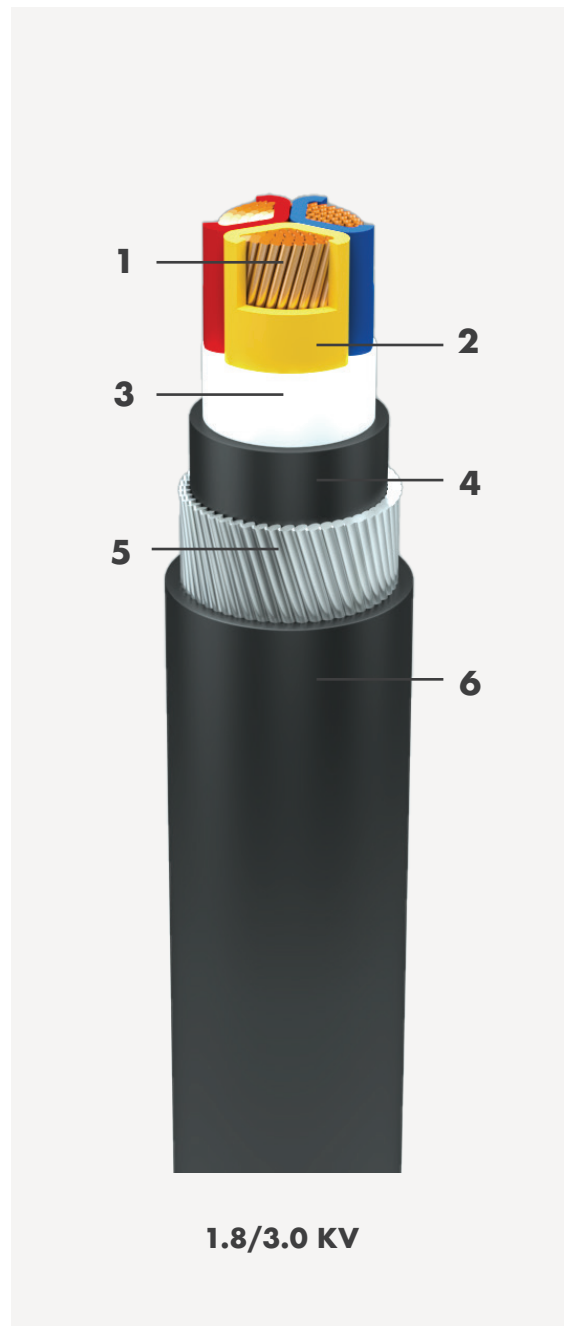

APPLICATION STANDARDS

Power Cables are designed and tested to meet the requirements of below standard:

- BS 5467

Oman Cables can also supply a range of alternative designs to meet customer specified requirements.

CORE COLOUR IDENTIFICATION



Note: Oman Cables has the capability to provide colour identification as per project requirements.

CHARACTERISTICS

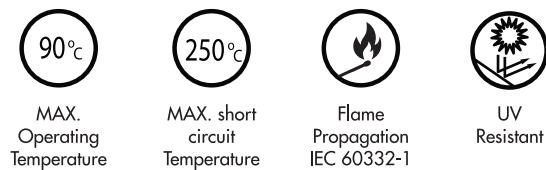

CABLE INSTALLATION

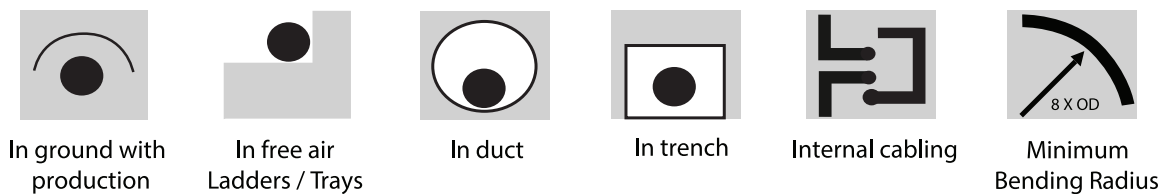

Cable size (mm ²)	Electrical Parameters						Current Rating *							
	DC Resistance (Ω /km)	AC Resistance (Ω /km)	Reactance (Approx.) at 50Hz. (Ω /km)	Impedance (Approx.) at 50Hz. (Ω /km)	Voltage Drop (Approx.) (mV/A/m)	Ground at 35°C, (A)	Duct at 35°C, (A)	Air at 50°C, (A)	Ground at 35°C, (A)	Duct at 35°C, (A)	Air at 50°C, (A)			
	1 C	3C	1 C	3C	1 C	3C	1 C	3C	1 C	3C	1 C	3C		
1.5	-	-	-	-	-	-	-	-	-	-	-	-		
2.5	-	-	-	-	-	-	-	-	-	-	-	-		
4	-	-	-	-	-	-	-	-	-	-	-	-		
6	-	-	-	-	-	-	-	-	-	-	-	-		
10	-	-	-	-	-	-	-	-	-	-	-	-		
16	1.150	1.470	-	0.104	-	1.47	-	2.55	-	98	-	83	-	87
25	0.727	0.927	-	0.098	-	0.93	-	1.61	-	126	-	107	-	116
35	0.524	0.668	-	0.092	-	0.67	-	1.17	-	151	-	126	-	138
50	0.387	0.494	0.117	0.089	0.51	0.50	0.88	0.87	178	188	150	187	166	
70	0.268	0.342	0.109	0.083	0.36	0.35	0.62	0.61	218	227	184	234	209	
95	0.193	0.247	0.106	0.080	0.27	0.26	0.46	0.45	261	267	221	287	256	
120	0.153	0.197	0.103	0.078	0.22	0.21	0.38	0.37	297	294	252	334	296	
150	0.124	0.160	0.100	0.077	0.19	0.18	0.33	0.31	333	323	282	380	337	
185	0.099	0.128	0.096	0.074	0.16	0.15	0.28	0.26	375	356	319	434	387	
240	0.075	0.099	0.093	0.073	0.14	0.12	0.23	0.21	432	399	368	512	455	
300	0.060	0.080	0.090	0.072	0.12	0.11	0.21	0.19	484	435	413	583	520	
400	0.047	0.065	0.089	0.070	0.11	0.10	0.19	0.16	544	460	472	664	597	
500	0.037	0.053	0.087	-	0.10	-	0.18	-	-	498	-	751	-	-
630	0.028	0.043	0.085	-	0.10	-	0.17	-	-	537	-	846	-	-
800	0.022	0.038	0.085	-	0.09	-	0.16	-	-	559	-	919	-	-
1000	0.018	0.032	0.084	-	0.09	-	0.16	-	-	593	-	997	-	-

Physical Dimensions					
Approx. Cable OD, mm		Approx. Cable Weight, kg/km		Standard Drum Length, m	
1 C	3 C	1 C	3 C	1 C	3 C
-	-	-	-	-	-
-	-	-	-	-	-
-	-	-	-	-	-
-	-	-	-	-	-
-	-	-	-	-	-
-	-	-	-	-	-
-	27.5	-	1480	-	1000
-	30.0	-	1875	-	1000
-	30.0	-	2025	-	1000
19.0	33.5	730	2695	1000	500
20.5	36.5	940	3400	1000	500
22.0	39.5	1210	4255	1000	500
25.0	44.0	1540	5505	1000	500
26.5	47.0	1815	6450	1000	500
28.0	49.0	2185	7640	1000	500
30.5	54.5	2750	9500	500	500
32.5	59.5	3355	11425	500	500
37.0	63.0	4275	14050	500	250
40.5	-	5360	-	500	-
44.5	-	6800	-	500	-
51.0	-	8765	-	500	-
55.5	-	10785	-	500	-

Applicable standard: BS 5467
 Flame retardant property: IEC 60332-1

*Depth of laying in ground 0.8 Mtr.
 Thermal resistivity of soil 1.2 K.m/W
 1 Core cables are considered with Trefoil touching.

SINGLE CORE COPPER CONDUCTOR, PVC (TYPE A) INSULATION, PVC BEDDING, ALUMINIUM WIRE ARMoured & PVC SHEATH, POWER CABLE.

APPLICATION

For outdoor installations in power stations, industrial plants and switchgears if mechanical protection is required or in applications where mechanical damages are expected to occur.

CONSTRUCTION

Multi-Stranded Annealed Plain Copper conductor, PVC (TYPE A) insulation, Extruded PVC Bedding, Aluminium Round Wire Armour and Overall Extruded PVC Outer Sheath.

1. Conductor

Annealed Plain Copper (Multi Stranded, Class-2)

2. Insulation

Extruded PVC (TYPE A)

3. Bedding

Extruded PVC

4. Armour

Aluminium Round Wire

5. Outer Sheath

Extruded Overall PVC Outer Sheath.

APPLICATION STANDARDS

Power Cables are designed and tested to meet the requirements of below standard:

- IEC 60502-1

Oman Cables can also supply a range of alternative designs to meet customer specified requirements.

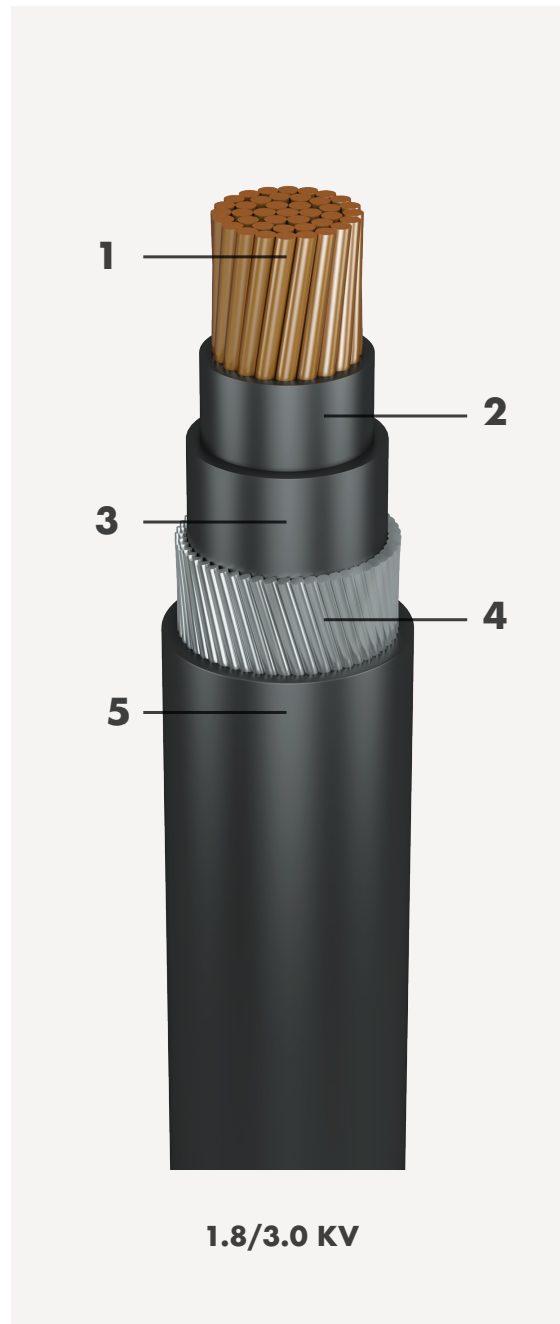

CORE COLOUR IDENTIFICATION

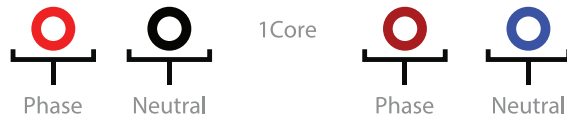

Note: Oman Cables has the capability to provide colour identification as per project requirements.

CHARACTERISTICS

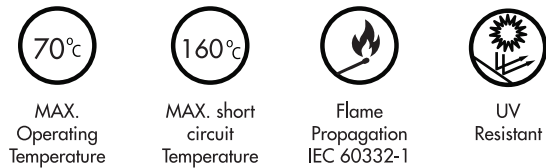

CABLE INSTALLATION

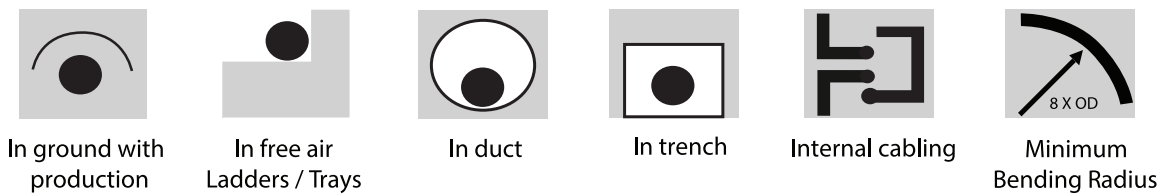

MULTI CORE

COPPER CONDUCTOR, PVC (TYPE A) INSULATION, PVC BEDDING, GALVANIZED STEEL ROUND WIRE ARMoured & PVC SHEATH, POWER CABLE

APPLICATION

For outdoor installations in power stations, industrial plants and switchgears if mechanical protection is required or in applications where mechanical damages are expected to occur.

CONSTRUCTION

Stranded Annealed Plain Copper Conductor, PVC (TYPE A) insulation, Non-hygroscopic Fillers & Binder tape (as required), Extruded PVC Bedding, Galvanized Steel Round Wire Armoured and Overall Extruded PVC Outer Sheath.

1. Conductor

Annealed Plain Copper (Multi Stranded, Class-2)

2. Insulation

Extruded PVC (TYPE A)

3. Fillers & Binder Tape

Non-hygroscopic Fillers & binder tape

4. Bedding

Extruded PVC

5. Armour

Galvanized Steel Wire

6. Outer Sheath

Extruded Overall PVC Outer Sheath.

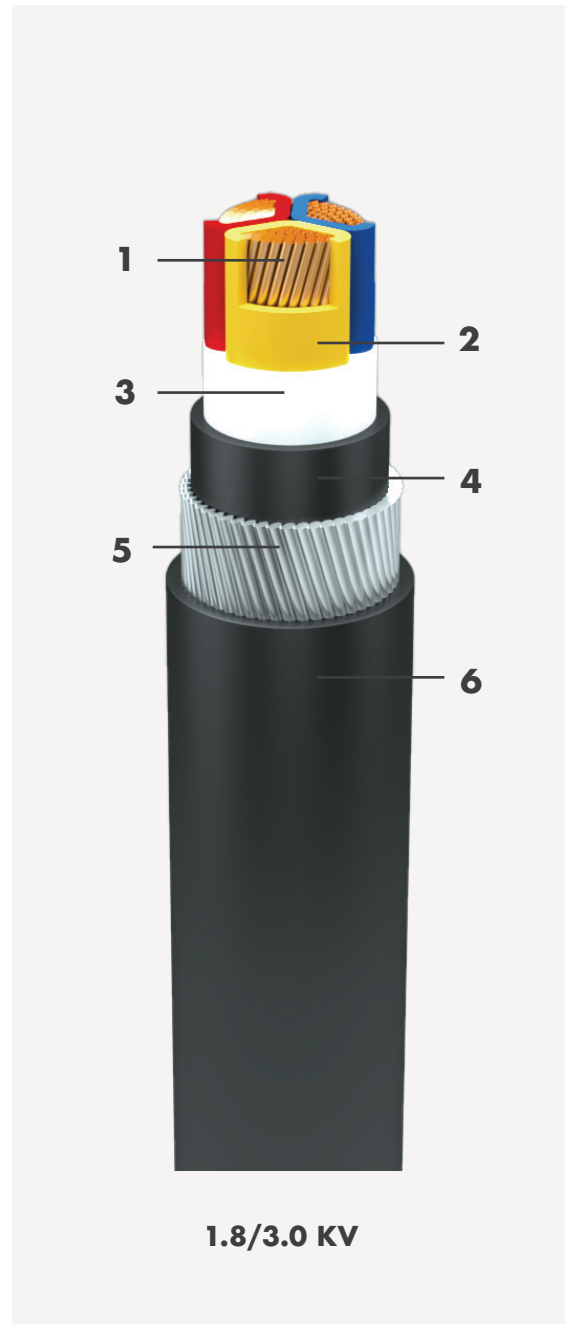

APPLICATION STANDARDS

Power Cables are designed and tested to meet the requirements of below standard:

- IEC 60502-1

Oman Cables can also supply a range of alternative designs to meet customer specified requirements.

CORE COLOUR IDENTIFICATION



Note: Oman Cables has the capability to provide colour identification as per project requirements.

CHARACTERISTICS

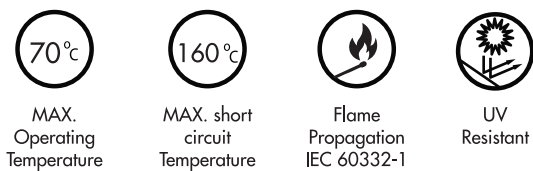

CABLE INSTALLATION

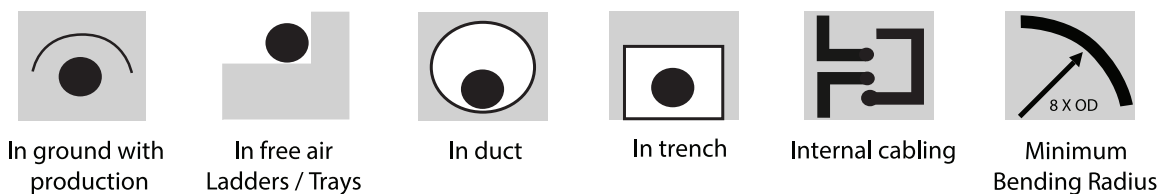

Cable size (mm ²)	Electrical Parameters						Current Rating *					
	DC Resistance (Ω/km)	AC Resistance (Ω/km)	Reactance (Approx.) at 50Hz. (Ω/km)		Impedance (Approx.) at 50Hz. (Ω/km)		Voltage Drop (Approx.) (mV/A/m)		Ground at 35°C, (A)		Air at 50°C, (A)	
			1 C	3C	1 C	3C	1 C	3C	1 C	3 C	1 C	3 C
16	1.150	1.380	0.135	0.107	1.390	1.380	2.408	2.390	81	78	62	60
25	0.727	0.870	0.130	0.101	0.880	0.877	1.524	1.519	107	100	85	79
35	0.524	0.628	0.124	0.094	0.640	0.635	1.109	1.100	127	121	102	96
50	0.387	0.464	0.119	0.091	0.479	0.473	0.830	0.819	154	142	131	116
70	0.268	0.322	0.109	0.084	0.340	0.333	0.589	0.577	189	175	163	145
95	0.193	0.232	0.106	0.081	0.255	0.247	0.442	0.428	226	211	202	178
120	0.153	0.185	0.103	0.079	0.212	0.201	0.367	0.348	255	239	233	206
150	0.124	0.150	0.100	0.078	0.180	0.170	0.312	0.294	286	269	265	235
185	0.099	0.121	0.097	0.076	0.155	0.144	0.268	0.249	321	303	304	270
240	0.075	0.093	0.094	0.074	0.132	0.120	0.229	0.208	367	349	356	318
300	0.060	0.075	0.093	0.074	0.119	0.107	0.206	0.185	410	390	407	362
400	0.047	0.060	0.090	0.073	0.108	0.096	0.187	0.166	453	438	462	415
500	0.037	0.049	0.088		0.101		0.175		497		520	
630	0.028	0.040	0.087		0.096		0.166		542		582	
800	0.022	0.034	0.086		0.092		0.159		566		628	
1000	0.018	0.030	0.084		0.089		0.154		595		677	

Physical Dimensions					
Approx. Cable OD, mm		Approx. Cable Weight, kg/km		Standard Drum Length, m	
1 C	3 C	1 C	3 C	1 C	3 C
15.0	28.0	373	1529	1000	1000
17.0	31.0	517	969	1000	500
18.0	30.5	628	1078	1000	500
19.5	34.5	767	1418	1000	500
21.0	37.0	993	1783	1000	500
23.5	40.5	1323	2236	1000	500
25.0	45.0	1580	2841	1000	500
26.5	48.0	1868	3325	1000	500
28.5	50.0	2239	3895	1000	500
31.0	56.0	1409	4872	500	500
34.5	62.0	1766	2975	500	250
38.0	67.5	2212	3827	500	250
41.5		2774		500	
46.0		3493		500	
51.5		4460		500	
56.0		5507		500	

Applicable standard: IEC 60502-1
 Flame retardant property: IEC 60332-3

SINGLE CORE ALUMINIUM CONDUCTOR, PVC (TYPE A) INSULATION, PVC BEDDING, ALUMINIUM WIRE ARMOURED & PVC SHEATH, POWER CABLE.

APPLICATION

For outdoor installations in power stations, industrial plants and switchgears if mechanical protection is required or in applications where mechanical damages are expected to occur.

CONSTRUCTION

Multi-Stranded Aluminium conductor, PVC (TYPE A) insulation, Extruded PVC Bedding, Aluminium Round Wire Armour and Overall Extruded PVC Outer Sheath.

1. Conductor

Aluminium (Multi Stranded, Class-2)

2. Insulation

Extruded PVC (TYPE A)

3. Bedding

Extruded PVC

4. Armour

Aluminium Round Wire

5. Outer Sheath

Extruded Overall PVC Outer Sheath.

APPLICATION STANDARDS

Power Cables are designed and tested to meet the requirements of below standard:

- IEC 60502-1

Oman Cables can also supply a range of alternative designs to meet customer specified requirements.

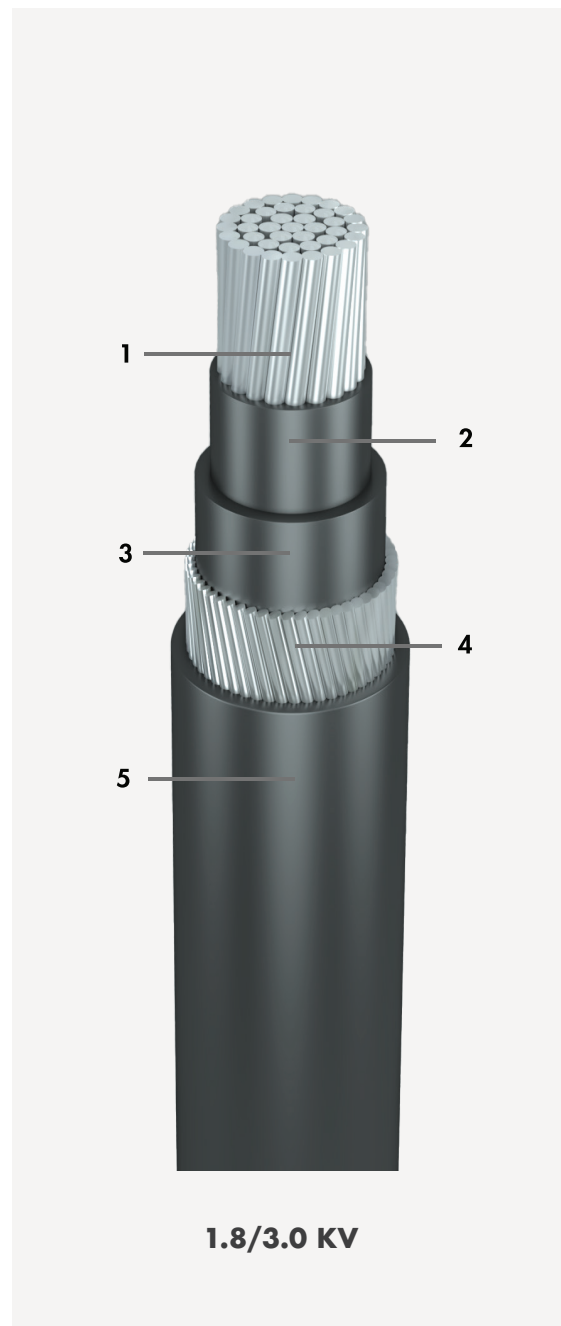

CORE COLOUR IDENTIFICATION

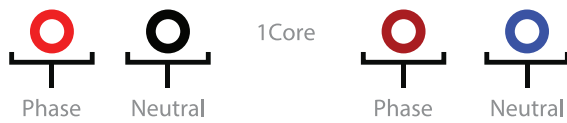

Note: Oman Cables has the capability to provide colour identification as per project requirements.

CHARACTERISTICS

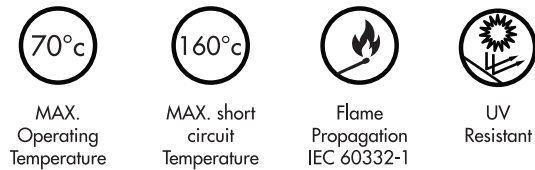

CABLE INSTALLATION

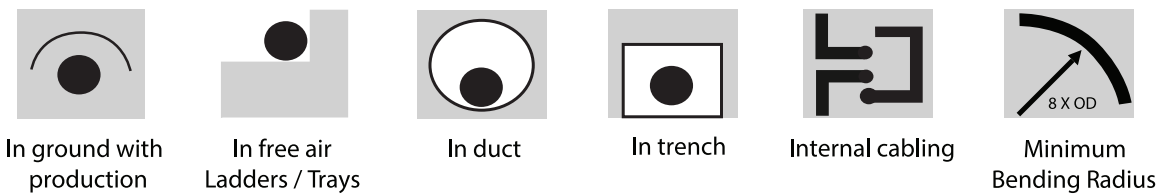

MULTI CORE

ALUMINIUM CONDUCTOR, PVC (TYPE A) INSULATION, PVC BEDDING, GALVANIZED STEEL ROUND WIRE ARMoured & PVC SHEATH, POWER CABLE.

APPLICATION

For outdoor installations in power stations, industrial plants and switchgears if mechanical protection is required or in applications where mechanical damages are expected to occur.

CONSTRUCTION

Stranded Aluminium Conductor, PVC (TYPE A) insulation, Non-hygroscopic Fillers & Binder tape (as required), Extruded PVC Bedding, Galvanized Steel Round Wire Armoured and Overall Extruded PVC Outer Sheath.

1. Conductor

Aluminium (Multi Stranded, Class-2)

2. Insulation

Extruded PVC (TYPE A)

3. Fillers & Binder Tape

Non-hygroscopic Fillers & binder tape

4. Bedding

Extruded PVC

5. Armour

Galvanized Steel Wire

6. Outer Sheath

Extruded Overall PVC Outer Sheath.

APPLICATION STANDARDS

Power Cables are designed and tested to meet the requirements of below standard:

- IEC 60502-1

Oman Cables can also supply a range of alternative designs to meet customer specified requirements.

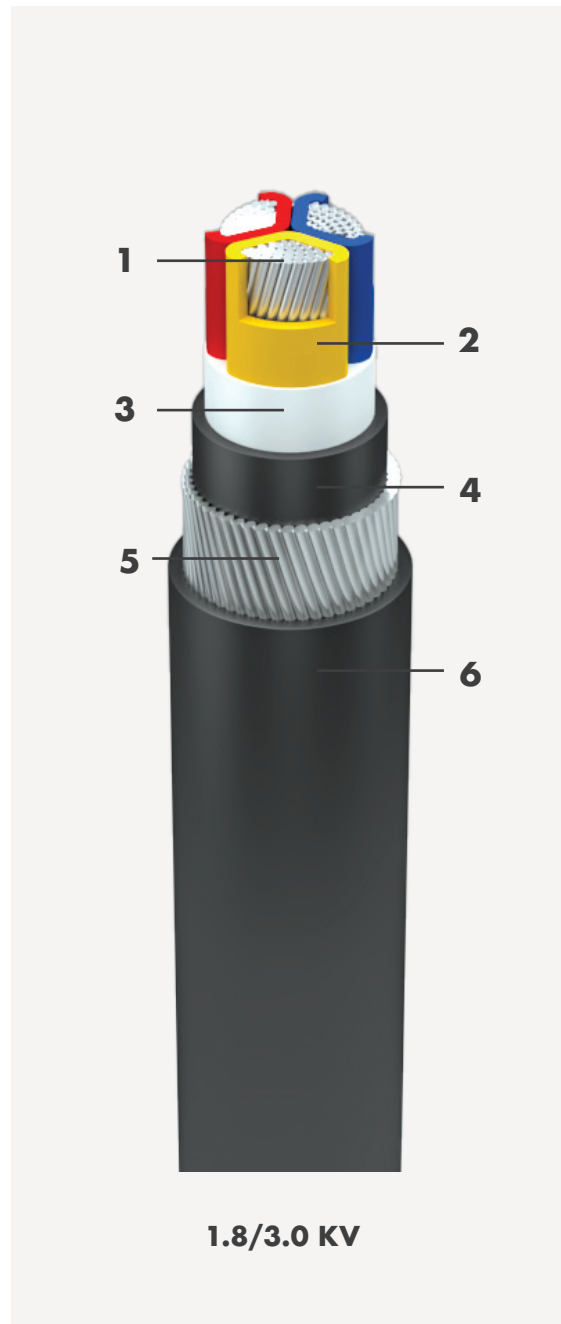

CORE COLOUR IDENTIFICATION



Note: Oman Cables has the capability to provide colour identification as per project requirements.

CHARACTERISTICS

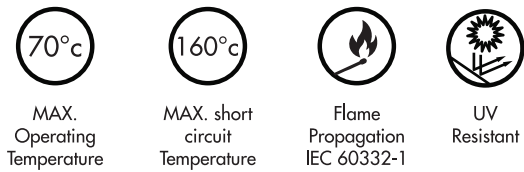

CABLE INSTALLATION

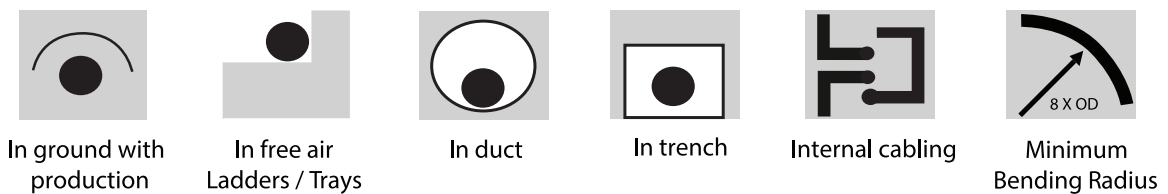

Cable size (mm ²)	Electrical Parameters						Current Rating *					
	DC Resis- tance (Ω/km)	AC Resis- tance (Ω/km)	Reactance (Approx.) at 50Hz. (Ω/km)		Impedance (Approx.) at 50Hz. (Ω/km)		Voltage Drop (Approx.) (mV/A/m)		Ground at 35°C, (A)		Air at 50°C, (A)	
			1 C	3C	1 C	3C	1 C	3C	1 C	3 C	1 C	3 C
16	1.910	2.300	0.135	0.107	2.300	2.300	3.984	3.984	62	59	47	46
25	1.200	1.440	0.130	0.101	1.450	1.440	2.511	2.494	82	76	64	60
35	0.868	1.040	0.124	0.094	1.050	1.040	1.819	1.801	97	91	81	72
50	0.641	0.771	0.119	0.091	0.780	0.776	1.351	1.344	118	109	96	87
70	0.443	0.533	0.109	0.084	0.544	0.540	0.942	0.935	144	134	121	110
95	0.320	0.385	0.106	0.081	0.399	0.394	0.691	0.682	172	161	148	135
120	0.253	0.305	0.103	0.079	0.322	0.315	0.558	0.546	195	184	171	156
150	0.206	0.249	0.100	0.078	0.268	0.261	0.464	0.452	218	206	194	178
185	0.164	0.199	0.097	0.076	0.221	0.213	0.383	0.369	247	234	226	204
240	0.125	0.152	0.094	0.074	0.179	0.170	0.310	0.294	286	270	267	242
300	0.100	0.122	0.093	0.074	0.153	0.144	0.265	0.249	322	305	307	277
400	0.078	0.096	0.090	0.073	0.132	0.122	0.229	0.211	369	327	364	303
500	0.061	0.076	0.088		0.116		0.201		409		413	
630	0.047	0.061	0.087		0.106		0.184		452		467	
800	0.037	0.050	0.086		0.099		0.171		498		529	
1000	0.029	0.042	0.084		0.094		0.163		533		582	

Physical Dimensions					
Approx. Cable OD, mm		Approx. Cable Weight, kg/km		Standard Drum Length, m	
1 C	3 C	1 C	3 C	1 C	3 C
15.0	28.0	277	1241	1000	1000
17.0	31.0	366	741	1000	500
18.0	30.5	417	759	1000	500
19.5	34.5	484	987	1000	500
21.0	37.0	588	1160	1000	500
23.5	40.5	753	1372	1000	500
25.0	45.0	858	1747	1000	500
26.5	48.0	977	1965	1000	500
28.5	50.0	1128	2206	1000	500
31.0	56.0	675	2658	500	500
34.5	62.0	845	1579	500	250
38.0	67.5	1039	2026	500	250
41.5		1259		500	
46.0		1538		500	
51.5		1939		500	
56.0		2350		500	

Applicable standard: IEC 60502-1
 Flame retardant property: IEC 60332-3

600/1000 LV CONTROL CABLES UNARMoured

MULTI CORE COPPER CONDUCTOR, XLPE INSULATION, UNARMOURED & PVC SHEATH, LOW VOLTAGE CONTROL CABLE.

APPLICATION

For use indoors - in cable trenches or ducts; and outdoors - in power stations, industrial plants and switchgears if mechanical protection is not required, or in applications where the cable is not exposed to mechanical damage.

CONSTRUCTION

Stranded Annealed Plain Copper Conductor, XLPE insulation, Non-hygroscopic Fillers & Binder tape (as required) and Overall Extruded PVC Outer Sheath.

1. Conductor

Annealed Plain Copper (Multi Stranded, Class-2)

2. Insulation

XLPE

3. Fillers & Binder Tape

Non-hygroscopic Fillers & binder tape

4. Outer Sheath

Extruded Overall PVC Outer Sheath.

APPLICATION STANDARDS

Power Cables are designed and tested to meet the requirements of below standard:

- IEC 60502-1

Oman Cables can also supply a range of alternative designs to meet customer specified requirements.

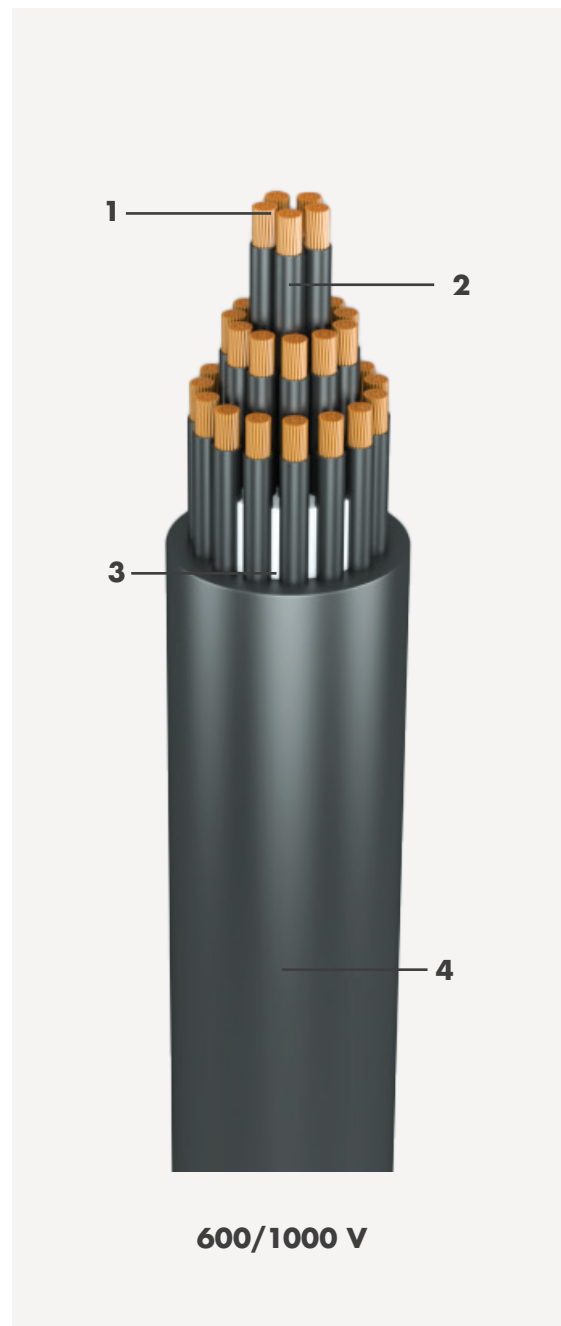

CORE COLOUR IDENTIFICATION

Core identification shall be provided by White cores with Black number printing.

Note: Oman Cables has the capability to provide colour identification as per project requirements.

CHARACTERISTICS



MAX.
Operating
Temperature



MAX. short
circuit
Temperature



Flame
Propagation
IEC 60332-1



UV
Resistant

CABLE INSTALLATION



In ground with
production



In free air
Ladders / Trays



In duct

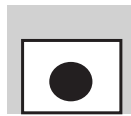

In trench



Internal cabling

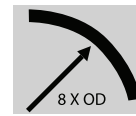

Minimum
Bending Radius

Electrical Parameters															
Nbr. Of Cores	DC Resistance at 20°C (Max)			AC Resistance at 90°C (Approx.)			Reactance at 50Hz. (Approx.)			Impedance at 50Hz. (Approx.)			Voltage Drop (Approx.)		
	1.5mm ² (Ω/km)	2.5mm ² (Ω/km)	4mm ² (Ω/km)	1.5mm ² (Ω/km)	2.5mm ² (Ω/km)	4mm ² (Ω/km)	1.5mm ² (Ω/km)	2.5mm ² (Ω/km)	4mm ² (Ω/km)	1.5mm ² (Ω/km)	2.5mm ² (Ω/km)	4mm ² (Ω/km)	1.5mm ² (mV/A/m)	2.5mm ² (mV/A/m)	4mm ² (mV/A/m)
6	12.1	7.41	4.61	15.43	9.45	5.88	0.105	0.099	0.093	15.43	9.45	5.88	30.86	18.9	11.76
7	12.1	7.41	4.61	15.43	9.45	5.88	0.105	0.099	0.093	15.43	9.45	5.88	30.86	18.9	11.76
8	12.1	7.41	4.61	15.43	9.45	5.88	0.105	0.099	0.093	15.43	9.45	5.88	30.86	18.9	11.76
9	12.1	7.41	4.61	15.43	9.45	5.88	0.105	0.099	0.093	15.43	9.45	5.88	30.86	18.9	11.76
10	12.1	7.41	4.61	15.43	9.45	5.88	0.105	0.099	0.093	15.43	9.45	5.88	30.86	18.9	11.76
12	12.1	7.41	4.61	15.43	9.45	5.88	0.105	0.099	0.093	15.43	9.45	5.88	30.86	18.9	11.76
15	12.1	7.41	4.61	15.43	9.45	5.88	0.105	0.099	0.093	15.43	9.45	5.88	30.86	18.9	11.76
19	12.1	7.41	4.61	15.43	9.45	5.88	0.105	0.099	0.093	15.43	9.45	5.88	30.86	18.9	11.76
21	12.1	7.41	4.61	15.43	9.45	5.88	0.105	0.099	0.093	15.43	9.45	5.88	30.86	18.9	11.76
24	12.1	7.41	4.61	15.43	9.45	5.88	0.105	0.099	0.093	15.43	9.45	5.88	30.86	18.9	11.76
27	12.1	7.41	4.61	15.43	9.45	5.88	0.105	0.099	0.093	15.43	9.45	5.88	30.86	18.9	11.76
36	12.1	7.41	4.61	15.43	9.45	5.88	0.105	0.099	0.093	15.43	9.45	5.88	30.86	18.9	11.76

Current Rating *																	
Physical Dimensions						Physical Dimensions											
Ground at 35°C			Duct at 35°C			Air at 50°C			Impedance at 50Hz. (Approx.)			Voltage Drop (Approx.)			Standard Drum Length		
1.5mm ²	2.5mm ²	4mm ²	1.5mm ²	2.5mm ²	4mm ²	1.5mm ²	2.5mm ²	4mm ²	1.5mm ²	2.5mm ²	4mm ²	1.5mm ²	2.5mm ²	4mm ²	1.5mm ²	2.5mm ²	4mm ²
(A)	(A)	(A)	(A)	(A)	(A)	(A)	(A)	(A)	(mm)	(mm)	(mm)	(kg/km)	(kg/km)	(kg/km)	(m)	(m)	(m)
22	28	38	18	23	31	15	20	26	12.5	13.5	15.0	210	275	380	1000	1000	1000
21	26	35	17	22	29	14	19	25	12.5	13.5	15.0	220	300	415	1000	1000	1000
20	25	34	16	21	28	13	18	23	13.5	15.0	16.5	255	345	475	1000	1000	1000
19	24	32	15	20	26	13	17	22	14.5	16.0	18.0	290	390	540	1000	1000	1000
18	23	31	15	19	25	12	17	21	15.5	17.0	19.5	305	415	580	1000	1000	1000
17	22	29	14	18	24	11	16	20	16.0	18.0	20.0	345	475	665	1000	1000	1000
16	20	27	13	17	22	11	14	19	17.5	19.5	22.0	420	575	815	1000	1000	1000
15	18	25	12	15	20	10	13	17	18.5	20.5	23.5	495	690	985	1000	1000	1000
14	18	24	11	15	20	9	13	17	19.5	22.0	24.5	545	760	1090	1000	1000	1000
13	17	22	11	14	18	9	12	16	21.5	24.0	27.5	615	860	1235	1000	1000	1000
13	16	21	10	13	17	8	11	15	22.0	25.0	28.0	675	945	1360	1000	1000	1000
11	14	19	9	12	16	8	10	13	25.0	28.0	31.5	865	1225	1780	1000	1000	1000

Applicable standard: IEC 60502-1
Flame retardant property: IEC 60332-3

MULTI CORE COPPER CONDUCTOR, PVC (TYPE A) INSULATION, UNARMoured & PVC SHEATH, LOW VOLTAGE CONTROL CABLE.

APPLICATION

For use indoors - in cable trenches or ducts; and outdoors - in power stations, industrial plants and switchgears if mechanical protection is not required, or in applications where the cable is not exposed to mechanical damage.

CONSTRUCTION

Stranded Annealed Plain Copper Conductor, PVC (TYPE A) insulation, Non-hygroscopic Fillers & Binder tape (as required) and Overall Extruded PVC Outer Sheath.

1. Conductor

Annealed Plain Copper (Multi Stranded, Class-2)

2. Insulation

Extruded PVC (TYPE A)

3. Fillers & Binder Tape

Non-hygroscopic Fillers & binder tape

4. Outer Sheath

Extruded Overall PVC Outer Sheath.

APPLICATION STANDARDS

Power Cables are designed and tested to meet the requirements of below standard:

- IEC 60502-1

Oman Cables can also supply a range of alternative designs to meet customer specified requirements.

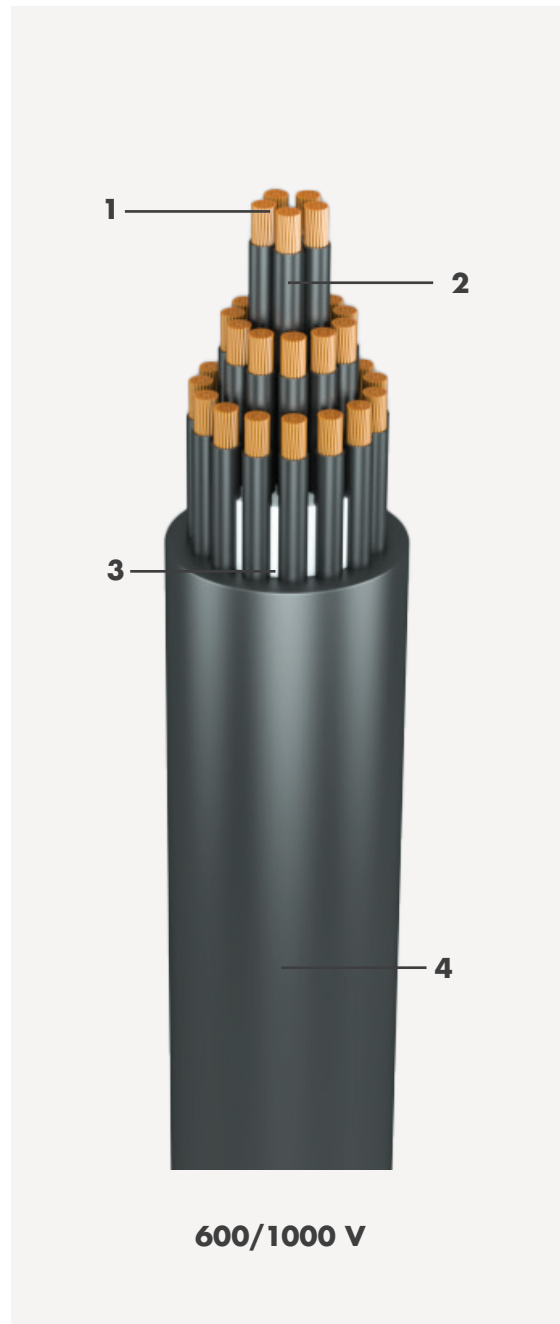

CORE COLOUR IDENTIFICATION

Core identification shall be provided by White cores with Black number printing.

Note: Oman Cables has the capability to provide colour identification as per project requirements.

CHARACTERISTICS



MAX.
Operating
Temperature



MAX. short
circuit
Temperature



Flame
Propagation
IEC 60332-1



UV
Resistant

CABLE INSTALLATION



In ground with
production



In free air
Ladders / Trays



In duct

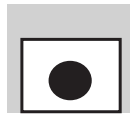

In trench



Internal cabling

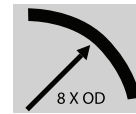

Minimum
Bending Radius

Nbr. Of Cores		Electrical Parameters														
		DC Resistance at 20°C (Max)			AC Resistance at 90°C (Approx.)			Reactance at 50Hz. (Approx.)			Impedance at 50Hz. (Approx.)			Voltage Drop (Approx.)		
(Nos.)		1.5mm ²	2.5mm ²	4mm ²	1.5mm ²	2.5mm ²	4mm ²	1.5mm ²	2.5mm ²	4mm ²	1.5mm ²	2.5mm ²	4mm ²	1.5mm ²	2.5mm ²	4mm ²
		(Ω/km)	(Ω/km)	(Ω/km)	(Ω/km)	(Ω/km)	(Ω/km)	(Ω/km)	(Ω/km)	(Ω/km)	(Ω/km)	(Ω/km)	(Ω/km)	(mV/A/m)	(mV/A/m)	(mV/A/m)
6		12.1	7.41	4.61	14.48	8.87	5.52	0.11	0.103	0.102	14.48	8.87	5.52	28.96	17.74	11.04
7		12.1	7.41	4.61	14.48	8.87	5.52	0.11	0.103	0.102	14.48	8.87	5.52	28.96	17.74	11.04
8		12.1	7.41	4.61	14.48	8.87	5.52	0.11	0.103	0.102	14.48	8.87	5.52	28.96	17.74	11.04
9		12.1	7.41	4.61	14.48	8.87	5.52	0.11	0.103	0.102	14.48	8.87	5.52	28.96	17.74	11.04
10		12.1	7.41	4.61	14.48	8.87	5.52	0.11	0.103	0.102	14.48	8.87	5.52	28.96	17.74	11.04
12		12.1	7.41	4.61	14.48	8.87	5.52	0.11	0.103	0.102	14.48	8.87	5.52	28.96	17.74	11.04
15		12.1	7.41	4.61	14.48	8.87	5.52	0.11	0.103	0.102	14.48	8.87	5.52	28.96	17.74	11.04
19		12.1	7.41	4.61	14.48	8.87	5.52	0.11	0.103	0.102	14.48	8.87	5.52	28.96	17.74	11.04
21		12.1	7.41	4.61	14.48	8.87	5.52	0.11	0.103	0.102	14.48	8.87	5.52	28.96	17.74	11.04
24		12.1	7.41	4.61	14.48	8.87	5.52	0.11	0.103	0.102	14.48	8.87	5.52	28.96	17.74	11.04
27		12.1	7.41	4.61	14.48	8.87	5.52	0.11	0.103	0.102	14.48	8.87	5.52	28.96	17.74	11.04
36		12.1	7.41	4.61	14.48	8.87	5.52	0.11	0.103	0.102	14.48	8.87	5.52	28.96	17.74	11.04

Current Rating *										Physical Dimensions																			
Ground at 35°C					Duct at 35°C					Air at 50°C					Impedance at 50Hz. (Approx.)					Voltage Drop (Approx.)					Standard Drum Length				
1.5mm ²	2.5mm ²	4mm ²	1.5mm ²	2.5mm ²	4mm ²	1.5mm ²	2.5mm ²	4mm ²	1.5mm ²	2.5mm ²	4mm ²	1.5mm ²	2.5mm ²	4mm ²	1.5mm ²	2.5mm ²	4mm ²	1.5mm ²	2.5mm ²	4mm ²	1.5mm ²	2.5mm ²	4mm ²						
(A)	(A)	(A)	(A)	(A)	(A)	(A)	(A)	(A)	(A)	(A)	(A)	(A)	(A)	(A)	(A)	(A)	(A)	(kg/km)	(kg/km)	(kg/km)	(m)	(m)	(m)						
17	22	29	14	18	24	11	15	19	13.0	14.5	17.0	240	315	460	1000	1000	1000	1000	1000	1000	1000	1000	1000						
16	21	28	13	17	23	10	14	18	13.0	14.5	17.0	260	340	505	1000	1000	1000	1000	1000	1000	1000	1000	1000						
16	20	26	13	16	22	10	13	17	14.0	15.5	18.5	300	395	590	1000	1000	1000	1000	1000	1000	1000	1000	1000						
15	19	25	12	15	21	9	13	17	15.5	17.0	20.0	345	455	680	1000	1000	1000	1000	1000	1000	1000	1000	1000						
14	18	24	12	15	20	9	12	16	16.5	18.0	21.5	360	480	715	1000	1000	1000	1000	1000	1000	1000	1000	1000						
14	17	23	11	14	19	8	11	15	17.0	18.5	22.5	410	545	820	1000	1000	1000	1000	1000	1000	1000	1000	1000						
12	16	21	10	13	17	8	11	14	18.5	20.5	25.0	495	665	1005	1000	1000	1000	1000	1000	1000	1000	1000	1000						
11	15	19	9	12	16	7	10	13	19.5	21.5	26.5	590	800	1215	1000	1000	1000	1000	1000	1000	1000	1000	1000						
11	14	19	9	11	15	7	9	12	20.5	23.0	28.0	655	890	1350	1000	1000	1000	1000	1000	1000	1000	1000	1000						
10	13	18	8	11	14	6	9	12	23.0	25.5	31.0	735	1000	1535	1000	1000	1000	1000	1000	1000	1000	1000	500						
10	13	17	8	10	14	6	8	11	23.5	26.0	32.0	810	1100	1705	1000	1000	1000	1000	1000	1000	1000	1000	500						
9	11	15	7	9	12	6	8	10	26.0	29.5	36.0	1040	1435	2225	1000	1000	1000	1000	1000	1000	1000	1000	500						

Applicable standard: IEC 60502-1
Flame retardant property: IEC 60332-3

*Depth of laying in ground 0.5 Mtr.
Thermal resistivity of soil 1.2 K.m/W

600/1000 LV CONTROL CABLES ARMOURED

MULTI CORE COPPER CONDUCTOR, XLPE INSULATION, PVC BEDDING, GALVANIZED STEEL ROUND WIRE ARMOURED & PVC SHEATH, LOW VOLTAGE CONTROL CABLE.

APPLICATION

For outdoor installations in power stations, industrial plants and switchgears if mechanical protection is required or in applications where mechanical damages are expected to occur.

CONSTRUCTION

Stranded Annealed Plain Copper Conductor, XLPE insulation, Non-hygroscopic Fillers & Binder tape (as required), Extruded PVC Bedding, Galvanized Steel Round Wire Armoured and Overall Extruded PVC Outer Sheath.

1. Conductor

Annealed Plain Copper (Multi Stranded, Class-2)

2. Insulation

XLPE

3. Fillers & Binder Tape

Non-hygroscopic Fillers & binder tape

4. Bedding

Extruded PVC

5. Armour

Galvanized Steel Wire

6. Outer Sheath

Extruded Overall PVC Outer Sheath.

APPLICATION STANDARDS

Power Cables are designed and tested to meet the requirements of below standard:

- IEC 60502-1

Oman Cables can also supply a range of alternative designs to meet customer specified requirements.

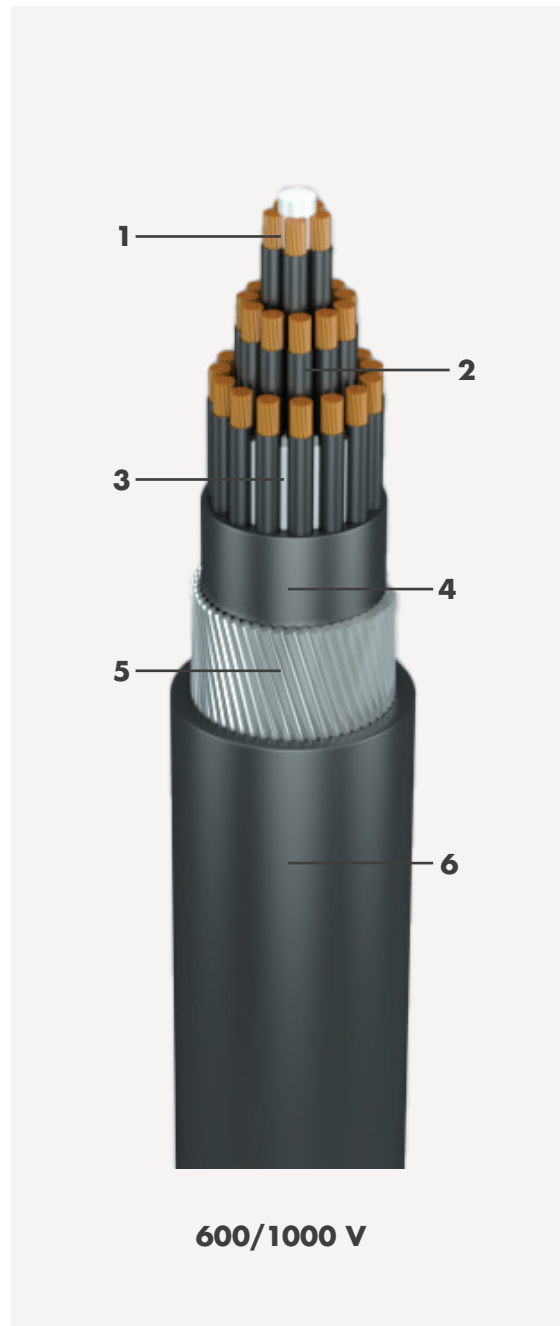

CORE COLOUR IDENTIFICATION

Core identification shall be provided by White cores with Black number printing.

Note: Oman Cables has the capability to provide colour identification as per project requirements.

CHARACTERISTICS



MAX.
Operating
Temperature



MAX. short
circuit
Temperature



Flame
Propagation
IEC 60332-1



UV
Resistant

CABLE INSTALLATION



In ground with
production



In free air
Ladders / Trays



In duct

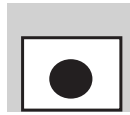

In trench



Internal cabling

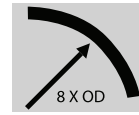

Minimum
Bending Radius

Electrical Parameters															
Nbr. Of Cores	DC Resistance at 20°C (Max)			AC Resistance at 90°C (Approx.)			Reactance at 50Hz. (Approx.)			Impedance at 50Hz. (Approx.)			Voltage Drop (Approx.)		
	1.5mm ² (Ω/km)	2.5mm ² (Ω/km)	4mm ² (Ω/km)	1.5mm ² (Ω/km)	2.5mm ² (Ω/km)	4mm ² (Ω/km)	1.5mm ² (Ω/km)	2.5mm ² (Ω/km)	4mm ² (Ω/km)	1.5mm ² (Ω/km)	2.5mm ² (Ω/km)	4mm ² (Ω/km)	1.5mm ² (mV/A/m)	2.5mm ² (mV/A/m)	4mm ² (mV/A/m)
6	12.1	7.41	4.61	15.43	9.45	5.88	0.105	0.099	0.093	15.43	9.45	5.88	30.86	18.9	11.76
7	12.1	7.41	4.61	15.43	9.45	5.88	0.105	0.099	0.093	15.43	9.45	5.88	30.86	18.9	11.76
8	12.1	7.41	4.61	15.43	9.45	5.88	0.105	0.099	0.093	15.43	9.45	5.88	30.86	18.9	11.76
9	12.1	7.41	4.61	15.43	9.45	5.88	0.105	0.099	0.093	15.43	9.45	5.88	30.86	18.9	11.76
10	12.1	7.41	4.61	15.43	9.45	5.88	0.105	0.099	0.093	15.43	9.45	5.88	30.86	18.9	11.76
12	12.1	7.41	4.61	15.43	9.45	5.88	0.105	0.099	0.093	15.43	9.45	5.88	30.86	18.9	11.76
15	12.1	7.41	4.61	15.43	9.45	5.88	0.105	0.099	0.093	15.43	9.45	5.88	30.86	18.9	11.76
19	12.1	7.41	4.61	15.43	9.45	5.88	0.105	0.099	0.093	15.43	9.45	5.88	30.86	18.9	11.76
21	12.1	7.41	4.61	15.43	9.45	5.88	0.105	0.099	0.093	15.43	9.45	5.88	30.86	18.9	11.76
24	12.1	7.41	4.61	15.43	9.45	5.88	0.105	0.099	0.093	15.43	9.45	5.88	30.86	18.9	11.76
27	12.1	7.41	4.61	15.43	9.45	5.88	0.105	0.099	0.093	15.43	9.45	5.88	30.86	18.9	11.76
36	12.1	7.41	4.61	15.43	9.45	5.88	0.105	0.099	0.093	15.43	9.45	5.88	30.86	18.9	11.76

Current Rating *										Physical Dimensions																			
Ground at 35°C					Duct at 35°C					Air at 50°C					Impedance at 50Hz. (Approx.)					Voltage Drop (Approx.)					Standard Drum Length				
1.5mm ²	2.5mm ²	4mm ²	1.5mm ²	2.5mm ²	4mm ²	1.5mm ²	2.5mm ²	4mm ²	1.5mm ²	2.5mm ²	4mm ²	1.5mm ²	2.5mm ²	4mm ²	1.5mm ²	2.5mm ²	4mm ²	1.5mm ²	2.5mm ²	4mm ²	1.5mm ²	2.5mm ²	4mm ²						
(A)	(A)	(A)	(A)	(A)	(A)	(A)	(A)	(A)	(A)	(A)	(A)	(A)	(A)	(A)	(A)	(A)	(A)	(kg/km)	(kg/km)	(kg/km)	(m)	(m)	(m)						
22	28	38	18	23	31	16	21	29	16.0	18.0	19.5	430	590	725	1000	1000	1000	1000	1000	1000	1000	1000	1000						
21	26	35	17	22	29	15	20	27	16.0	18.0	19.5	445	615	765	1000	1000	1000	1000	1000	1000	1000	1000	1000						
20	25	34	16	21	28	14	19	26	17.5	19.0	20.5	565	690	860	1000	1000	1000	1000	1000	1000	1000	1000	1000						
19	24	32	15	20	26	14	18	25	18.5	20.0	22.0	625	760	960	1000	1000	1000	1000	1000	1000	1000	1000	1000						
18	23	31	15	19	25	13	18	24	19.5	21.5	24.0	665	810	1140	1000	1000	1000	1000	1000	1000	1000	1000	1000						
17	22	29	14	18	24	12	17	22	20.0	22.0	24.5	720	890	1245	1000	1000	1000	1000	1000	1000	1000	1000	1000						
16	20	27	13	17	22	12	15	21	22.0	24.5	27.0	825	1135	1450	1000	1000	1000	1000	1000	1000	1000	1000	1000						
15	18	25	12	15	20	11	14	19	22.5	25.5	28.0	925	1285	1655	1000	1000	1000	1000	1000	1000	1000	1000	1000						
14	18	24	11	15	20	10	14	18	24.5	26.5	29.5	1105	1395	1795	1000	1000	1000	1000	1000	1000	1000	1000	1000						
13	17	22	11	14	18	10	13	17	26.5	29.0	32.5	1250	1565	2025	1000	1000	1000	1000	1000	1000	1000	1000	500						
13	16	21	10	13	17	9	12	16	27.0	29.5	33.0	1310	1655	2170	1000	1000	1000	1000	1000	1000	1000	1000	500						
11	14	19	9	12	16	8	11	15	29.5	32.5	37.5	1590	2030	2955	1000	1000	1000	1000	1000	1000	1000	1000	500						

Applicable standard : IEC 60502-1
 Flame retardant property: IEC 60332-3

*Depth of laying in ground 0.5 Mtr.
 Thermal resistivity of soil 1.2 K.m/W

MULTI CORE COPPER CONDUCTOR, PVC (TYPE A) INSULATION, PVC BEDDING, GALVANIZED STEEL ROUND WIRE ARMOURED & PVC SHEATH, LOW VOLTAGE CONTROL CABLE.

APPLICATION

For outdoor installations in power stations, industrial plants and switchgears if mechanical protection is required or in applications where mechanical damages are expected to occur.

CONSTRUCTION

Stranded Annealed Plain Copper Conductor, PVC (TYPE A) insulation, Non-hygroscopic Fillers & Binder tape (as required), Extruded PVC Bedding, Galvanized Steel Round Wire Armoured and Overall Extruded PVC Outer Sheath.

1. Conductor

Annealed Plain Copper (Multi Stranded, Class-2)

2. Insulation

PVC (Type A)

3. Fillers & Binder Tape

Non-hygroscopic Fillers & binder tape

4. Bedding

Extruded PVC

5. Armour

Galvanized Steel Wire

6. Outer Sheath

Extruded Overall PVC Outer Sheath.

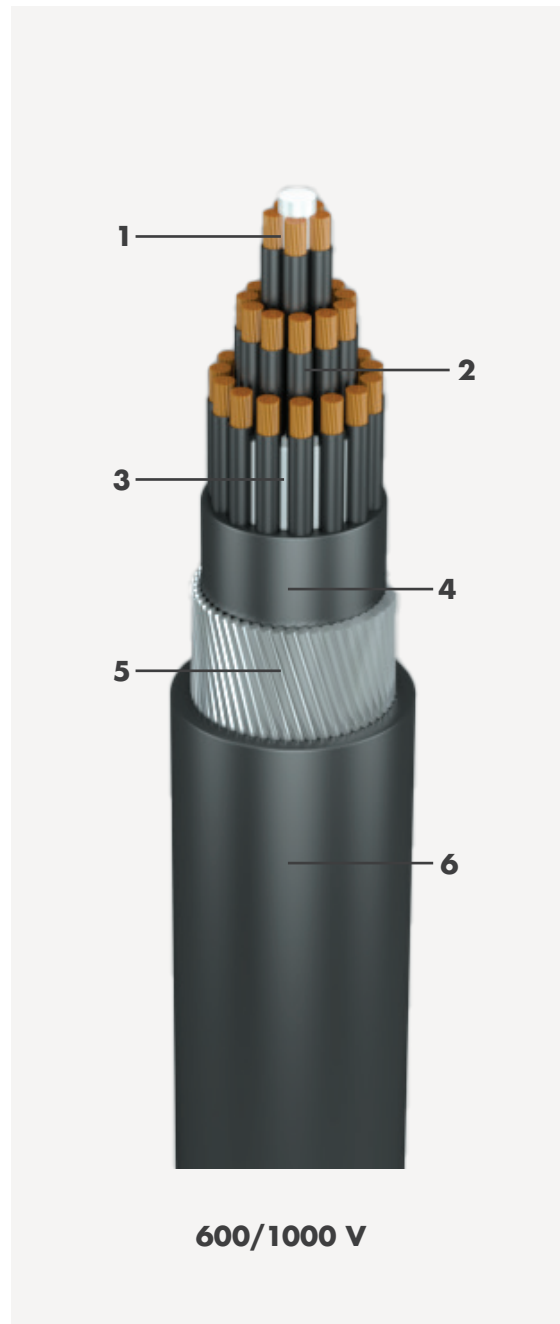

APPLICATION STANDARDS

Power Cables are designed and tested to meet the requirements of below standard:

- IEC 60502-1

Oman Cables can also supply a range of alternative designs to meet customer specified requirements.

CORE COLOUR IDENTIFICATION

Core identification shall be provided by White cores with Black number printing.

Note: Oman Cables has the capability to provide colour identification as per project requirements.

CHARACTERISTICS



MAX.
Operating
Temperature



MAX. short
circuit
Temperature



Flame
Propagation
IEC 60332-1



UV
Resistant

CABLE INSTALLATION



In ground with
production



In free air
Ladders / Trays



In duct

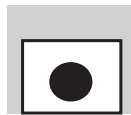

In trench



Internal cabling



Minimum
Bending Radius

Electrical Parameters															
Nbr. Of Cores (Nos.)	DC Resistance at 20°C (Max)			AC Resistance at 90°C (Approx.)			Reactance at 50Hz. (Approx.)			Impedance at 50Hz. (Approx.)			Voltage Drop (Approx.)		
	1.5mm ² (Ω/km)	2.5mm ² (Ω/km)	4mm ² (Ω/km)	1.5mm ² (Ω/km)	2.5mm ² (Ω/km)	4mm ² (Ω/km)	1.5mm ² (Ω/km)	2.5mm ² (Ω/km)	4mm ² (Ω/km)	1.5mm ² (Ω/km)	2.5mm ² (Ω/km)	4mm ² (Ω/km)	1.5mm ² (mV/A/m)	2.5mm ² (mV/A/m)	4mm ² (mV/A/m)
6	12.1	7.41	4.61	14.48	8.87	5.52	0.11	0.103	0.102	14.48	8.87	5.52	28.96	17.74	11.04
7	12.1	7.41	4.61	14.48	8.87	5.52	0.11	0.103	0.102	14.48	8.87	5.52	28.96	17.74	11.04
8	12.1	7.41	4.61	14.48	8.87	5.52	0.11	0.103	0.102	14.48	8.87	5.52	28.96	17.74	11.04
9	12.1	7.41	4.61	14.48	8.87	5.52	0.11	0.103	0.102	14.48	8.87	5.52	28.96	17.74	11.04
10	12.1	7.41	4.61	14.48	8.87	5.52	0.11	0.103	0.102	14.48	8.87	5.52	28.96	17.74	11.04
12	12.1	7.41	4.61	14.48	8.87	5.52	0.11	0.103	0.102	14.48	8.87	5.52	28.96	17.74	11.04
15	12.1	7.41	4.61	14.48	8.87	5.52	0.11	0.103	0.102	14.48	8.87	5.52	28.96	17.74	11.04
19	12.1	7.41	4.61	14.48	8.87	5.52	0.11	0.103	0.102	14.48	8.87	5.52	28.96	17.74	11.04
21	12.1	7.41	4.61	14.48	8.87	5.52	0.11	0.103	0.102	14.48	8.87	5.52	28.96	17.74	11.04
24	12.1	7.41	4.61	14.48	8.87	5.52	0.11	0.103	0.102	14.48	8.87	5.52	28.96	17.74	11.04
27	12.1	7.41	4.61	14.48	8.87	5.52	0.11	0.103	0.102	14.48	8.87	5.52	28.96	17.74	11.04
36	12.1	7.41	4.61	14.48	8.87	5.52	0.11	0.103	0.102	14.48	8.87	5.52	28.96	17.74	11.04

Current Rating *										Physical Dimensions																			
Ground at 35°C					Duct at 35°C					Air at 50°C					Impedance at 50Hz. (Approx.)					Voltage Drop (Approx.)					Standard Drum Length				
1.5mm ²	2.5mm ²	4mm ²	1.5mm ²	2.5mm ²	4mm ²	1.5mm ²	2.5mm ²	4mm ²	1.5mm ²	2.5mm ²	4mm ²	1.5mm ²	2.5mm ²	4mm ²	1.5mm ²	2.5mm ²	4mm ²	1.5mm ²	2.5mm ²	4mm ²	1.5mm ²	2.5mm ²	4mm ²						
(A)	(A)	(A)	(A)	(A)	(A)	(A)	(A)	(A)	(A)	(A)	(A)	(mm)	(mm)	(mm)	(kg/km)	(kg/km)	(kg/km)	(m)	(m)	(m)	(m)	(m)	(m)	(m)					
17	22	29	14	18	24	11	15	19	16.5	18.5	21.0	475	650	855	1000	1000	1000	1000	1000	1000	1000	1000	1000	1000					
16	21	28	13	17	23	10	14	18	16.5	18.5	21.0	495	675	900	1000	1000	1000	1000	1000	1000	1000	1000	1000	1000					
16	20	26	13	16	22	10	13	17	18.0	19.5	23.5	625	755	1130	1000	1000	1000	1000	1000	1000	1000	1000	1000	1000					
15	19	25	12	15	21	9	13	17	19.5	21.0	25.0	695	850	1260	1000	1000	1000	1000	1000	1000	1000	1000	1000	1000					
14	18	24	12	15	20	9	12	16	20.5	22.0	26.5	745	895	1345	1000	1000	1000	1000	1000	1000	1000	1000	1000	1000					
14	17	23	11	14	19	8	11	15	21.0	22.5	27.0	805	975	1470	1000	1000	1000	1000	1000	1000	1000	1000	1000	1000					
12	16	21	10	13	17	8	11	14	22.5	25.5	29.5	925	1260	1725	1000	1000	1000	1000	1000	1000	1000	1000	1000	1000					
11	15	19	9	12	16	7	10	13	24.5	26.5	31.0	1150	1430	1985	1000	1000	1000	1000	1000	1000	1000	1000	1000	1000					
11	14	19	9	11	15	7	9	12	25.5	28.0	33.0	1255	1555	2160	1000	1000	1000	1000	1000	1000	1000	1000	1000	1000					
10	13	18	8	11	14	6	9	12	27.5	30.5	37.5	1405	1735	2680	1000	1000	1000	1000	1000	1000	1000	1000	1000	1000					
10	13	17	8	10	14	6	8	11	28.0	31.0	38.0	1480	1855	2865	1000	1000	1000	1000	1000	1000	1000	1000	1000	1000					
9	11	15	7	9	12	6	8	10	31.0	34.5	42.0	1815	2285	3530	500	500	500	500	500	500	500	500	500	500					

Applicable standard : IEC 60502-1
 Flame retardant property: IEC 60332-3

*Depth of laying in ground 0.5 Mtr.
 Thermal resistivity of soil 1.2 K.m/W

DE-RATING & GROUP RATING FACTORS

Table 1:

Rating factors for variation in ambient temperature for cables laid in air (for installation in air only)

Ambient temperature °C	25	30	35	40	45	50	55
PVC insulated cables	1.49	1.40	1.31	1.22	1.12	1.00	0.87
XLPE insulated cables	1.28	1.23	1.18	1.13	1.06	1.00	0.94

Table 2:

Rating factors for variation in ground temperature for cables laid direct in the ground or in ducts (for installation in ground & ducts only)

Ground temperature °C	15	20	25	30	35	40	45
PVC insulated cables	1.25	1.19	1.13	1.06	1.00	0.93	0.84
XLPE insulated cables	1.16	1.13	1.08	1.03	1.00	0.95	0.90

Table 3:

Rating factors for depth of laying for cables laid direct in the ground (for installation in ground only)

Depth of Laying meter	600/1000 Volt cables			1800/3000 Volt or 1900/3300 Volt cables	
	Up to 50 mm ²	70 mm ² to 300 mm ²	Above 300 mm ²	Up to 300 mm ²	Above 300 mm ²
0.50	1.000	1.000	1.000	--	--
0.60	0.990	0.980	0.970	--	--
0.75	0.975	0.965	0.948	--	--
0.80	0.970	0.960	0.940	1.000	1.000
1.00	0.950	0.930	0.920	0.980	0.970
1.25	0.940	0.920	0.890	0.960	0.950
1.50	0.930	0.900	0.870	0.950	0.930
1.75	0.920	0.890	0.860	0.940	0.910
2.00	0.910	0.880	0.850	0.920	0.890
2.50	0.900	0.870	0.840	0.910	0.880
3 or more	0.890	0.850	0.820	0.900	0.860

Table 4:

Rating factors for depth of laying for cables laid in single way ducts (for installation in duct only)

Depth of Laying meter	600/1000 Volt cables		1800/3000 Volt or 1900/3300 Volt cables	
	Single Core	Multi Core	Single Core	Multi Core
0.50	1.000	1.000	--	--
0.60	0.980	0.990	--	--
0.75	0.958	0.983	--	--
0.80	0.950	0.980	1.000	1.000
1.00	0.930	0.960	0.980	0.990
1.25	0.910	0.950	0.950	0.970
1.50	0.890	0.940	0.940	0.960
1.75	0.880	0.940	0.920	0.960
2.00	0.870	0.930	0.910	0.950
2.50	0.860	0.920	0.890	0.940
3 or more	0.850	0.910	0.890	0.930

Table 5:

Rating factors for variation in thermal resistivity of soil for two or three single-core cables laid direct in the ground (for installation in ground only)

Nominal Area of Conductor mm ²	Thermal Resistivity of Soil in K.m/W										
	0.70	0.80	0.90	1.00	1.20	1.50	2.00	2.50	3.00	3.50	4.00
Up to 50	1.21	1.16	1.11	1.07	1.00	0.91	0.81	0.73	0.68	0.63	0.59
70	1.22	1.16	1.12	1.07	1.00	0.91	0.81	0.73	0.68	0.63	0.59
95	1.22	1.16	1.12	1.07	1.00	0.91	0.81	0.73	0.68	0.63	0.59
120	1.22	1.16	1.12	1.07	1.00	0.91	0.81	0.73	0.68	0.63	0.59
150	1.22	1.16	1.12	1.07	1.00	0.91	0.81	0.73	0.68	0.63	0.59
185	1.22	1.17	1.12	1.07	1.00	0.91	0.81	0.73	0.68	0.62	0.59
240	1.23	1.17	1.12	1.07	1.00	0.91	0.80	0.73	0.68	0.62	0.59
300	1.23	1.17	1.12	1.07	1.00	0.91	0.80	0.73	0.68	0.62	0.59
400	1.23	1.17	1.12	1.07	1.00	0.91	0.80	0.73	0.67	0.62	0.58
500	1.23	1.17	1.12	1.07	1.00	0.91	0.80	0.73	0.67	0.62	0.58
630	1.23	1.17	1.12	1.07	1.00	0.91	0.80	0.73	0.67	0.61	0.58
800	1.23	1.17	1.12	1.07	1.00	0.91	0.80	0.72	0.66	0.61	0.58
1000	1.24	1.18	1.12	1.07	1.00	0.91	0.80	0.72	0.66	0.61	0.58

Table 6:

Rating factors for variation in thermal resistivity of soil for twin or multi-core cables laid direct in the ground (for installation in ground only)

Nominal Area of Conductor mm ²	Thermal Resistivity of Soil in K.m/W										
	0.70	0.80	0.90	1.00	1.20	1.50	2.00	2.50	3.00	3.50	4.00
1.5	1.12	1.09	1.07	1.04	1.00	0.94	0.86	0.80	0.75	0.70	0.66
2.5	1.12	1.09	1.07	1.04	1.00	0.94	0.86	0.80	0.75	0.70	0.66
4	1.13	1.10	1.07	1.05	1.00	0.94	0.85	0.79	0.74	0.69	0.65
6	1.14	1.10	1.07	1.05	1.00	0.93	0.85	0.79	0.74	0.68	0.64
10	1.15	1.11	1.08	1.05	1.00	0.93	0.85	0.78	0.73	0.67	0.63
16	1.16	1.12	1.08	1.05	1.00	0.93	0.84	0.77	0.72	0.66	0.62
25	1.17	1.13	1.09	1.05	1.00	0.93	0.83	0.77	0.71	0.65	0.61
35	1.17	1.13	1.09	1.06	1.00	0.92	0.83	0.76	0.71	0.65	0.61
50	1.17	1.13	1.09	1.06	1.00	0.92	0.83	0.76	0.71	0.65	0.61
70	1.18	1.14	1.09	1.06	1.00	0.92	0.83	0.75	0.70	0.64	0.60
95	1.18	1.14	1.09	1.06	1.00	0.92	0.83	0.75	0.70	0.64	0.60
120	1.19	1.14	1.10	1.06	1.00	0.92	0.82	0.75	0.69	0.64	0.60
150	1.19	1.14	1.10	1.06	1.00	0.92	0.82	0.75	0.69	0.63	0.59
185	1.19	1.14	1.10	1.06	1.00	0.92	0.82	0.74	0.69	0.63	0.59
240	1.20	1.15	1.10	1.07	1.00	0.92	0.81	0.74	0.69	0.63	0.59
300	1.20	1.15	1.10	1.07	1.00	0.92	0.81	0.74	0.69	0.63	0.59
400	1.20	1.15	1.10	1.07	1.00	0.92	0.81	0.74	0.69	0.63	0.59

Table 7:

Rating factors for variation in thermal resistivity of soil for three single-core cables in ducts (for installation in duct only)

Nominal Area of Conductor mm ²	Thermal Resistivity of Soil in K.m/W										
	0.70	0.80	0.90	1.00	1.20	1.50	2.00	2.50	3.00	3.50	4.00
Up to 50	1.11	1.08	1.06	1.04	1.00	0.94	0.87	0.82	0.77	0.73	0.69
70	1.12	1.09	1.06	1.04	1.00	0.94	0.87	0.81	0.76	0.72	0.68
95	1.12	1.09	1.06	1.04	1.00	0.94	0.87	0.81	0.76	0.72	0.68
120	1.13	1.10	1.07	1.04	1.00	0.94	0.86	0.80	0.75	0.72	0.67
150	1.13	1.10	1.07	1.04	1.00	0.94	0.86	0.80	0.75	0.71	0.67
185	1.13	1.10	1.07	1.04	1.00	0.93	0.86	0.79	0.75	0.70	0.67
240	1.14	1.11	1.07	1.04	1.00	0.93	0.86	0.79	0.74	0.70	0.66
300	1.14	1.11	1.08	1.05	1.00	0.93	0.85	0.79	0.74	0.69	0.65
400	1.14	1.11	1.08	1.05	1.00	0.93	0.85	0.78	0.73	0.68	0.65
500	1.15	1.11	1.08	1.05	1.00	0.93	0.85	0.78	0.73	0.68	0.64
630	1.15	1.12	1.08	1.05	1.00	0.93	0.84	0.78	0.72	0.68	0.64
800	1.16	1.12	1.09	1.05	1.00	0.93	0.84	0.77	0.72	0.67	0.64
1000	1.16	1.13	1.09	1.05	1.00	0.92	0.84	0.77	0.71	0.67	0.63

Table 8:

Rating factors for variation in thermal resistivity of soil for twin or multi-core cables laid in single-way ducts (for installation in duct only)

Nominal Area of Conductor mm ²	Thermal Resistivity of Soil in K.m/W										
	0.70	0.80	0.90	1.00	1.20	1.50	2.00	2.50	3.00	3.50	4.00
1.5	1.04	1.03	1.02	1.02	1.00	0.98	0.94	0.91	0.88	0.86	0.83
2.5	1.04	1.03	1.02	1.02	1.00	0.98	0.94	0.91	0.88	0.86	0.83
4	1.04	1.04	1.03	1.02	1.00	0.97	0.94	0.90	0.87	0.85	0.82
6	1.05	1.04	1.03	1.02	1.00	0.97	0.93	0.90	0.86	0.84	0.81
10	1.05	1.04	1.03	1.02	1.00	0.97	0.93	0.89	0.86	0.83	0.80
16	1.06	1.04	1.03	1.02	1.00	0.97	0.92	0.88	0.85	0.82	0.79
25	1.06	1.05	1.03	1.02	1.00	0.96	0.92	0.88	0.84	0.82	0.78
35	1.06	1.05	1.03	1.02	1.00	0.96	0.92	0.87	0.83	0.81	0.77
50	1.07	1.05	1.03	1.02	1.00	0.96	0.91	0.87	0.83	0.80	0.77

Table 8 Continued:

Nominal Area of Conductor mm ²	Thermal Resistivity of Soil in K.m/W										
	0.70	0.80	0.90	1.00	1.20	1.50	2.00	2.50	3.00	3.50	4.00
70	1.07	1.05	1.04	1.02	1.00	0.96	0.91	0.86	0.82	0.79	0.76
95	1.07	1.06	1.04	1.02	1.00	0.96	0.91	0.86	0.82	0.78	0.75
120	1.08	1.06	1.04	1.03	1.00	0.95	0.90	0.85	0.81	0.78	0.74
150	1.09	1.06	1.04	1.03	1.00	0.95	0.90	0.85	0.80	0.77	0.73
185	1.09	1.07	1.05	1.03	1.00	0.95	0.89	0.84	0.80	0.76	0.72
240	1.09	1.07	1.05	1.03	1.00	0.95	0.89	0.84	0.79	0.76	0.72
300	1.10	1.07	1.05	1.03	1.00	0.95	0.88	0.83	0.78	0.75	0.71
400	1.10	1.07	1.05	1.03	1.00	0.95	0.88	0.83	0.78	0.75	0.71

Table 9:

Group rating factors for more than one circuit of 3 single core armoured or unarmoured cables laid direct in the ground (in trefoil touching or flat touching horizontal formation). And for installation in the ground only.

	No. of circuits	Touching		Spacing between centres of circuits (mtrs)			
		Trefoil	Laid Flat	0.15	0.30	0.45	0.60
"600/1000 Volt grade cables"	2	0.78	0.81	0.83	0.88	0.91	0.93
	3	0.66	0.70	0.73	0.79	0.84	0.87
	4	0.61	0.64	0.68	0.73	0.81	0.85
	5	0.56	0.60	0.64	0.73	0.79	0.83
	6	0.53	0.57	0.61	0.71	0.78	0.82
	7	0.50	0.54	0.59	0.69	0.76	0.82
	8	0.49	0.53	0.57	0.68	0.76	0.81
	9	0.47	0.51	0.56	0.67	0.75	0.81
	10	0.46	0.50	0.55	0.67	0.75	0.80
	11	0.44	0.49	0.54	0.66	0.74	0.80
	12	0.43	0.48	0.53	0.66	0.74	0.80
	"1800/3000 Volt or 1900/3300 Volt grade cables"	2	0.78	0.80	0.82	0.86	0.89
3		0.66	0.68	0.71	0.77	0.80	0.83
4		0.59	0.62	0.65	0.72	0.77	0.80
5		0.55	0.58	0.61	0.68	0.74	0.78
6		0.52	0.55	0.58	0.66	0.72	0.76
7		0.49	0.52	0.56	0.64	0.70	0.75
8		0.47	0.50	0.54	0.63	0.69	0.74
9		0.45	0.48	0.52	0.61	0.68	0.74
10		0.44	0.47	0.51	0.61	0.68	0.73
11		0.43	0.46	0.50	0.60	0.67	0.73
12		0.41	0.45	0.49	0.59	0.67	0.72

Table 10:

Group rating factors for more than one twin or multi-core armoured or unarmoured cables laid direct in the ground (in horizontal formation) For installation in ground only.

	No. of circuits	Touching		Spacing between centres of circuits (mtrs)			
		Trefoil	Laid Flat	0.15	0.30	0.45	0.60
"600/1000 Volt grade cables"	2	0.81	0.87	0.91	0.93	0.95	0.93
	3	0.70	0.78	0.84	0.88	0.90	0.87
	4	0.63	0.74	0.81	0.86	0.89	0.85
	5	0.59	0.70	0.78	0.84	0.87	0.83
	6	0.55	0.68	0.77	0.83	0.87	0.82
	7	0.52	0.66	0.75	0.82	0.86	0.82
	8	0.50	0.64	0.75	0.81	0.86	0.81
	9	0.48	0.63	0.74	0.81	0.85	0.81
	10	0.47	0.62	0.73	0.80	0.85	0.80
	11	0.45	0.61	0.73	0.80	0.85	0.80
	12	0.44	0.60	0.72	0.80	0.84	0.80
	"1800/3000 Volt or 1900/3300 Volt grade cables"	2	0.80	0.85	0.89	0.91	0.93
3		0.68	0.76	0.81	0.84	0.87	0.83
4		0.62	0.71	0.77	0.81	0.84	0.80
5		0.57	0.66	0.73	0.78	0.82	0.78
6		0.54	0.64	0.71	0.77	0.81	0.76
7		0.51	0.61	0.69	0.75	0.79	0.75
8		0.49	0.59	0.68	0.74	0.79	0.74
9		0.47	0.58	0.67	0.73	0.78	0.74
10		0.45	0.57	0.66	0.73	0.78	0.73
11		0.44	0.55	0.65	0.72	0.77	0.73
12		0.43	0.54	0.64	0.72	0.77	0.72

Table 11:

Group rating factors for more than one circuits of 3 single core armoured or unarmoured cables laid in single way ducts (In trefoil touching horizontal formation) (For installation in duct only)

	No. of circuits	Touching	Spacing between centres of circuits (mtrs)	
			0.45	0.60
"600/1000 Volt grade cables"	2	0.87	0.91	0.93
	3	0.78	0.84	0.87
	4	0.74	0.81	0.85
	5	0.70	0.79	0.83
	6	0.69	0.78	0.82
	7	0.67	0.76	0.82
	8	0.66	0.76	0.81
	9	0.65	0.75	0.81
	10	0.64	0.75	0.80
	11	0.63	0.74	0.80
	12	0.63	0.74	0.80
	"1800/3000 Volt or 1900/3300 Volt grade cables"	2	0.85	0.88
3		0.75	0.80	0.83
4		0.70	0.77	0.80
5		0.67	0.74	0.78
6		0.64	0.72	0.76
7		0.62	0.70	0.75
8		0.61	0.69	0.74
9		0.59	0.68	0.73
10		0.58	0.67	0.73
11		0.57	0.67	0.72
12		0.57	0.66	0.72

Table 12:

Group rating factors for more than one twin or multi-core armoured or unarmoured cables laid in single way ducts (in horizontal formation) For installation in the ground only.

	NO. OF CIRCUITS	SPACING BETWEEN CENTRES OF CIRCUITS (MTRS)			
		Touching	0.30	0.45	0.60
"600/1000 Volt grade cables"	2	0.90	0.93	0.95	0.96
	3	0.83	0.88	0.91	0.93
	4	0.79	0.85	0.89	0.92
	5	0.75	0.83	0.88	0.91
	6	0.73	0.82	0.87	0.90
	7	0.71	0.81	0.86	0.89
	8	0.70	0.80	0.85	0.89
	9	0.68	0.79	0.85	0.89
	10	0.67	0.79	0.85	0.89
	11	0.66	0.78	0.84	0.88
	12	0.66	0.78	0.84	0.88
	"1800/3000 Volt or 900/3300 Volt grade cables"	2	0.88	0.91	0.93
3		0.80	0.85	0.88	0.90
4		0.76	0.81	0.85	0.88
5		0.72	0.78	0.83	0.86
6		0.69	0.76	0.81	0.85
7		0.67	0.75	0.80	0.84
8		0.65	0.74	0.79	0.83
9		0.63	0.72	0.78	0.83
10		0.62	0.72	0.78	0.82
11		0.61	0.71	0.77	0.82
12		0.60	0.70	0.77	0.81

Table 13:

Reduction factors for group of more than one multi-core cable to be applied to reference current-carrying capacities for multi-core cables in free air

METHOD OF INSTALLATION IN TABLE A.52.3		NUMBER OF TRAYS OR LADDERS	NUMBER OF CABLES PER TRAY OR LADDER							
			1	2	3	4	6	9		
Perforated cable tray systems (note 3)	31	Touching		1	1.00	0,88	0,82	0,79	0,76	0,73
				2	1.00	0,87	0,80	0,77	0,73	0,68
				3	1.00	0,86	0,79	0,76	0,71	0,66
				6	1.00	0,84	0,77	0,73	0,68	0,64
		Spaced		1	1.00	1.00	0,98	0,95	0,91	-
				2	1.00	0,99	0,96	0,92	0,87	-
		3	1.00	0,98	0,95	0,91	0,85	-		
Vertical perforated cable tray systems (note 4)	31	Touching		1	1.00	0,88	0,82	0,78	0,73	0,72
				2	1.00	0,88	0,81	0,76	0,71	0,70
		Spaced		1	1.00	0,91	0,89	0,88	0,87	-
				2	1.00	0,91	0,88	0,87	0,85	-
Unperforated cable tray systems	31	Touching		1	0,97	0,84	0,78	0,75	0,71	0,68
				2	0,97	0,83	0,76	0,72	0,68	0,63
				3	0,97	0,82	0,75	0,71	0,66	0,61
				6	0,97	0,81	0,73	0,69	0,63	0,58
Cable ladder systems, cleats, etc. (note 3)	32	Touching		1	1.00	0,87	0,82	0,80	0,79	0,78
				2	1.00	0,86	0,80	0,78	0,76	0,73
	33			3	1.00	0,85	0,79	0,76	0,73	0,70
				6	1.00	0,84	0,77	0,73	0,68	0,64

METHOD OF INSTALLATION IN TABLE A.52.3		NUMBER OF TRAYS OR LADDERS	NUMBER OF CABLES PER TRAY OR LADDER					
			1	2	3	4	6	9
	1	1.00	1.00	1,00	1,00	1,00	-	
	2	1.00	0.99	0,98	0,97	0,96	-	
	3	1.00	0.98	0,97	0,96	0,93	-	

NOTE 1: Values given are averages for the cable types and range of conductor sizes considered in Tables A.52.8 to A.52.13 of IEC 60364-5-52. The spread of values is generally less than 5%

NOTE 2: Factors apply to single layer groups of cables as shown above and do not apply when cables are installed in more than one layer touching each other. Values for such installations may be significantly lower and has to be determined by an appropriate method.

NOTE 3: Values are given for vertical spacing between cable trays of 300 mm and at least 20 mm between cable trays and wall. For closer spacing the factors should be reduced.

NOTE 4: Values are given for horizontal spacing between cable trays of 225 mm with cable trays mounted back to back. For closer spacing the factors should be reduced.

Table 14:

Reduction factors for group of one or more circuits of single-core cables to be applied to reference current-carrying capacities for one circuit of single-core cables in free air

METHOD OF INSTALLATION IN TABLE A.52.3		NUMBER OF TRAYS OR LADDERS	NUMBER OF CABLES THREE-PHASE CIRCUITS PER TRAY OR LADDER			USE AS A MULTIPLIER TO CURRENT-CARRYING CAPACITY FOR			
			1	2	3				
Perforated cable tray systems (note 3)	31	Touching			1	0,98	0,91	0,87	Three cables in horizontal formation
		2	0,96		0,87	0,81			
		3	0,95		0,85	0,78			
Perforated cable tray systems (note 3)	31	Touching			1	0,96	0,86	-	Three cables in vertical formation
		2	0,95		0,84	-			
Vertical perforated cable tray systems (note 4)	32 33 34	Touching			1	1,00	0,97	0,96	Three cables in horizontal formation
		2	0,98		0,93	0,89			
		3	0,97		0,90	0,86			
Perforated cable tray systems (note 3)	31	Touching			1	1,00	0,98	0,96	
		2	0,97		0,93	0,89			
		3	0,96		0,92	0,86			
Vertical perforated cable tray systems (note 4)	31	Spaced			1	1,00	0,91	0,89	Three cables in trefoil formation
		2	1,00		0,90	0,86			
Cable ladder systems, cleats, etc. (note 3)	32 33 34	Touching			1	1,00	1,00	1,00	
		2	0,97		0,95	0,93			
		3	0,96		0,94	0,90			

SHORT CIRCUIT CURRENT RATING

SHORT CIRCUIT CURRENT RATING OF CONDUCTOR

Short circuit rating is dependent upon various factors, as listed below:

- a) Conductor material.
- b) Maximum continuous operating temperature & maximum temperature at short circuit.
- c) Fault duration.

$$I_{sc} = \frac{(k \cdot A)}{(\sqrt{t})}$$

where,

I_{sc} : Short circuit current rating

k : Constant (factor dependent upon operating temperature & short circuit temperature)

A : Total cross-sectional area (mm²)

t : Time duration (sec)

For XLPE insulated cables, the short circuit current rating of copper conductor is calculated by the formula mentioned above, considering continuous operating temperature as 90°C and short circuit temperature as 250°C.

For Copper conductor, the constant 'k' is 0.143, and,
For Aluminium conductor, the constant 'k' is 0.094.

Conductor Size	Copper Conductor		Aluminium Conductor	
	Short circuit rating for 1 sec.	Short circuit rating for 5 sec.	Short circuit rating for 1 sec.	Short circuit rating for 5 sec.
(mm ²)	(kA)	(kA)	(kA)	(kA)
1.5	0.21	0.1	0.14	0.06
2.5	0.36	0.16	0.24	0.11
4	0.57	0.26	0.38	0.17
6	0.86	0.38	0.56	0.25
10	1.43	0.64	0.94	0.42
16	2.29	1.02	1.5	0.67
25	3.58	1.6	2.35	1.05
35	5.01	2.24	3.29	1.47
50	7.15	3.2	4.7	2.1
70	10.01	4.48	6.58	2.94
95	13.59	6.08	8.93	3.99
120	17.16	7.67	11.28	5.04
150	21.45	9.59	14.1	6.31
185	26.46	11.83	17.39	7.78
240	34.32	15.35	22.56	10.09
300	42.9	19.19	28.2	12.61
400	57.2	25.58	37.6	16.82
500	71.5	31.98	47	21.02
630	90.09	40.29	59.22	26.48
800	114.4	51.16	75.2	33.63
1000	143	63.95	94	42.04

A) SHORT CIRCUIT CURRENT RATING CURVE FOR COPPER CONDUCTOR, XLPE INSULATION.

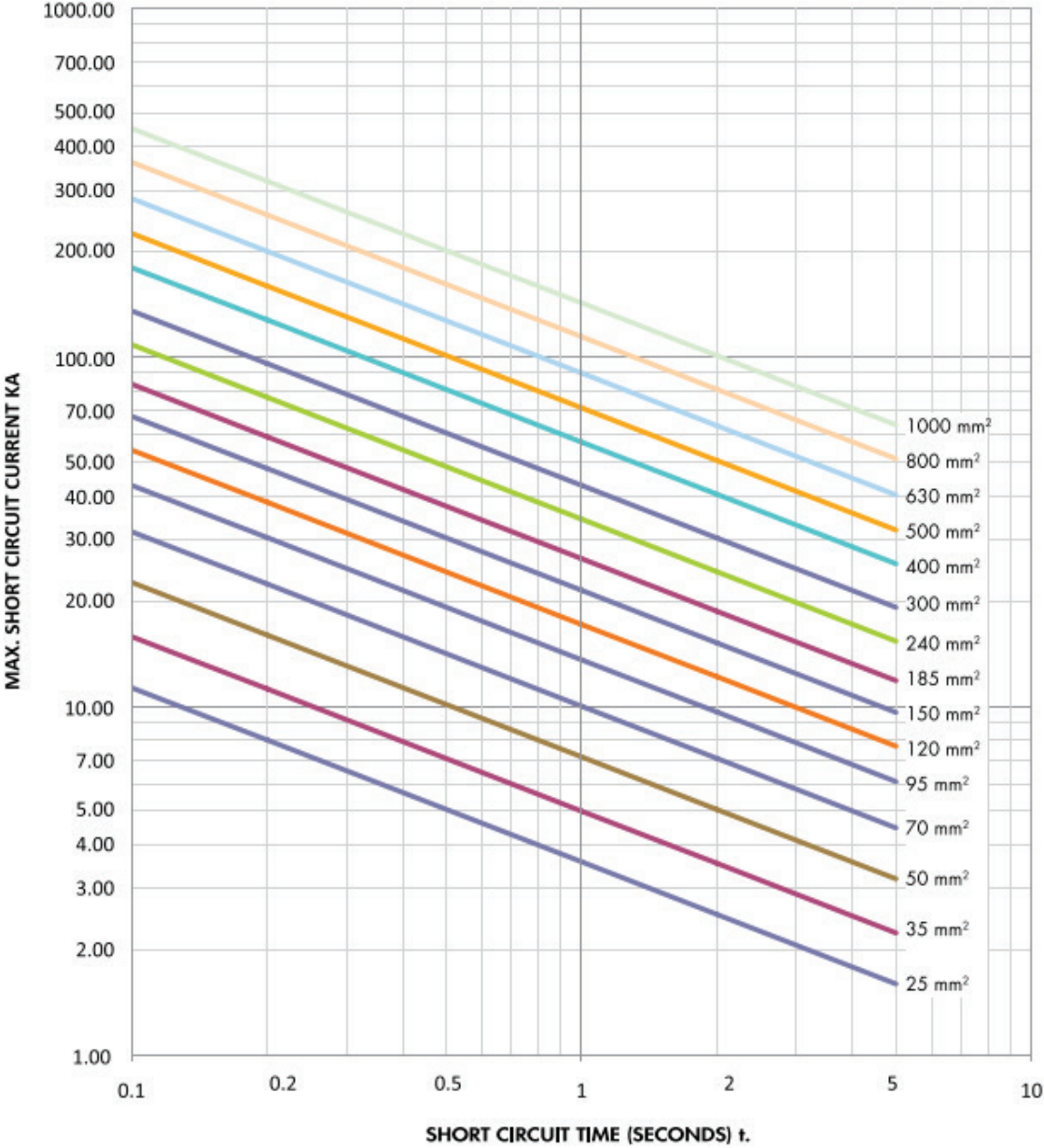

B) SHORT CIRCUIT CURRENT RATING CURVE FOR ALUMINIUM CONDUCTOR, XLPE INSULATION.

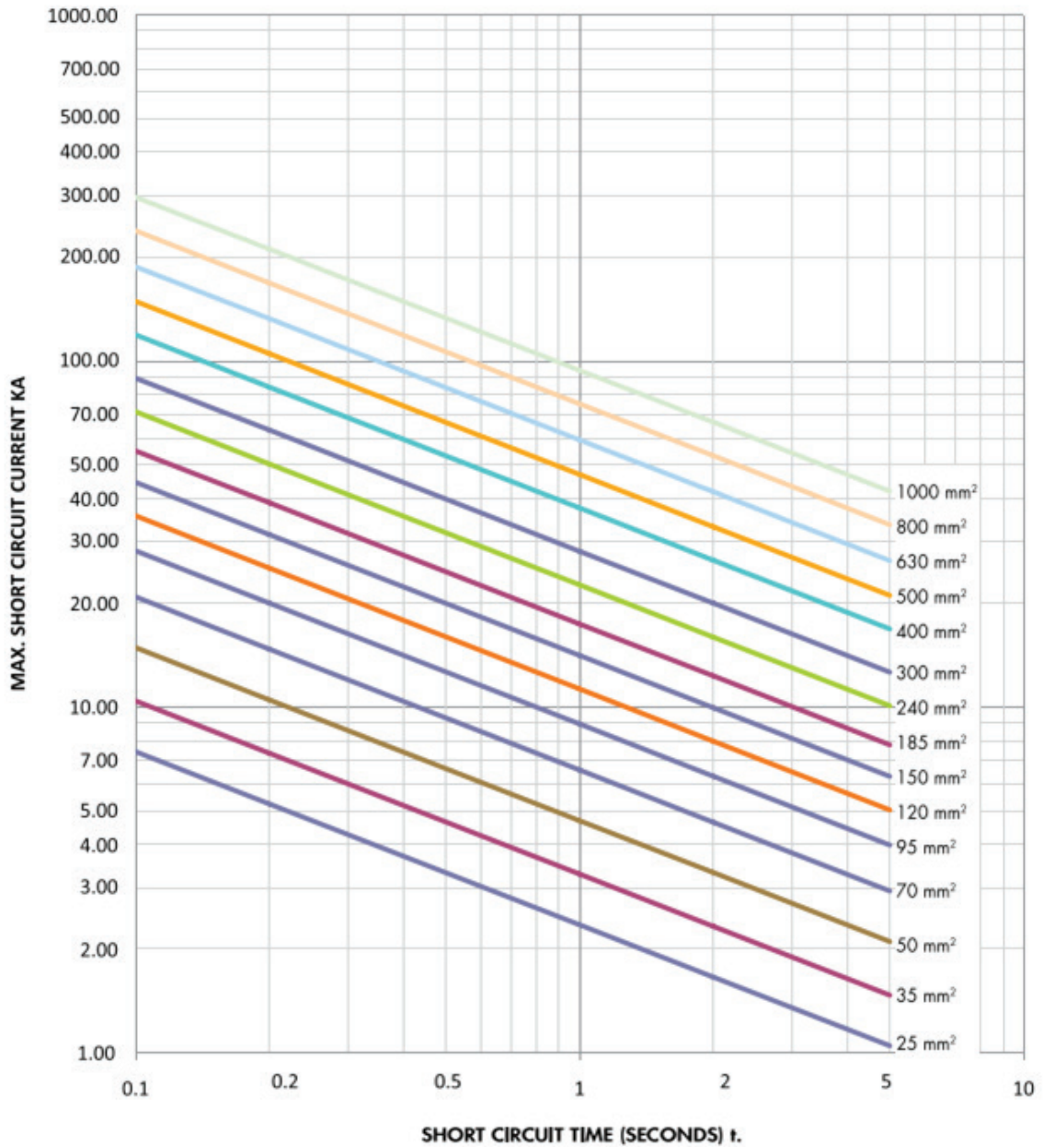

For PVC insulated cables, the short circuit current rating for copper conductors is calculated by the formula mentioned above, while considering the continuous operating temperature as 70 °C and the short circuit temperature as 160 °C up to 300mm² and 140 °C for sizes above this.

For Copper conductors, the constant 'k' is 0.115 up to 300mm² and 0.1028 for sizes above 300mm². For Aluminium conductors, the constant 'k' is 0.076 up to 300mm² and 0.068 for sizes above 300mm².

Conductor Size (mm ²)	Copper Conductor		Aluminium Conductor	
	Short circuit rating for 1 sec. (kA)	Short circuit rating for 5 sec. (kA)	Short circuit rating for 1 sec. (kA)	Short circuit rating for 5 sec. (kA)
1.5	0.17	0.08	0.11	0.05
2.5	0.29	0.13	0.19	0.08
4	0.46	0.21	0.3	0.14
6	0.69	0.31	0.46	0.2
10	1.15	0.51	0.76	0.34
16	1.84	0.82	1.22	0.54
25	2.88	1.29	1.9	0.85
35	4.03	1.8	2.66	1.19
50	5.75	2.57	3.8	1.7
70	8.05	3.6	5.32	2.38
95	10.93	4.89	7.22	3.23
120	13.8	6.17	9.12	4.08
150	17.25	7.71	11.4	5.1
185	21.28	9.51	14.06	6.29
240	27.6	12.34	18.24	8.16
300	34.5	15.43	22.8	10.2
400	41.12	18.39	27.2	12.16
500	51.4	22.99	34	15.21
630	64.76	28.96	42.84	19.16
800	82.24	36.78	54.4	24.33
1000	102.8	45.97	68	30.41

C) SHORT CIRCUIT CURRENT RATING CURVE FOR COPPER CONDUCTOR, PVC INSULATION.

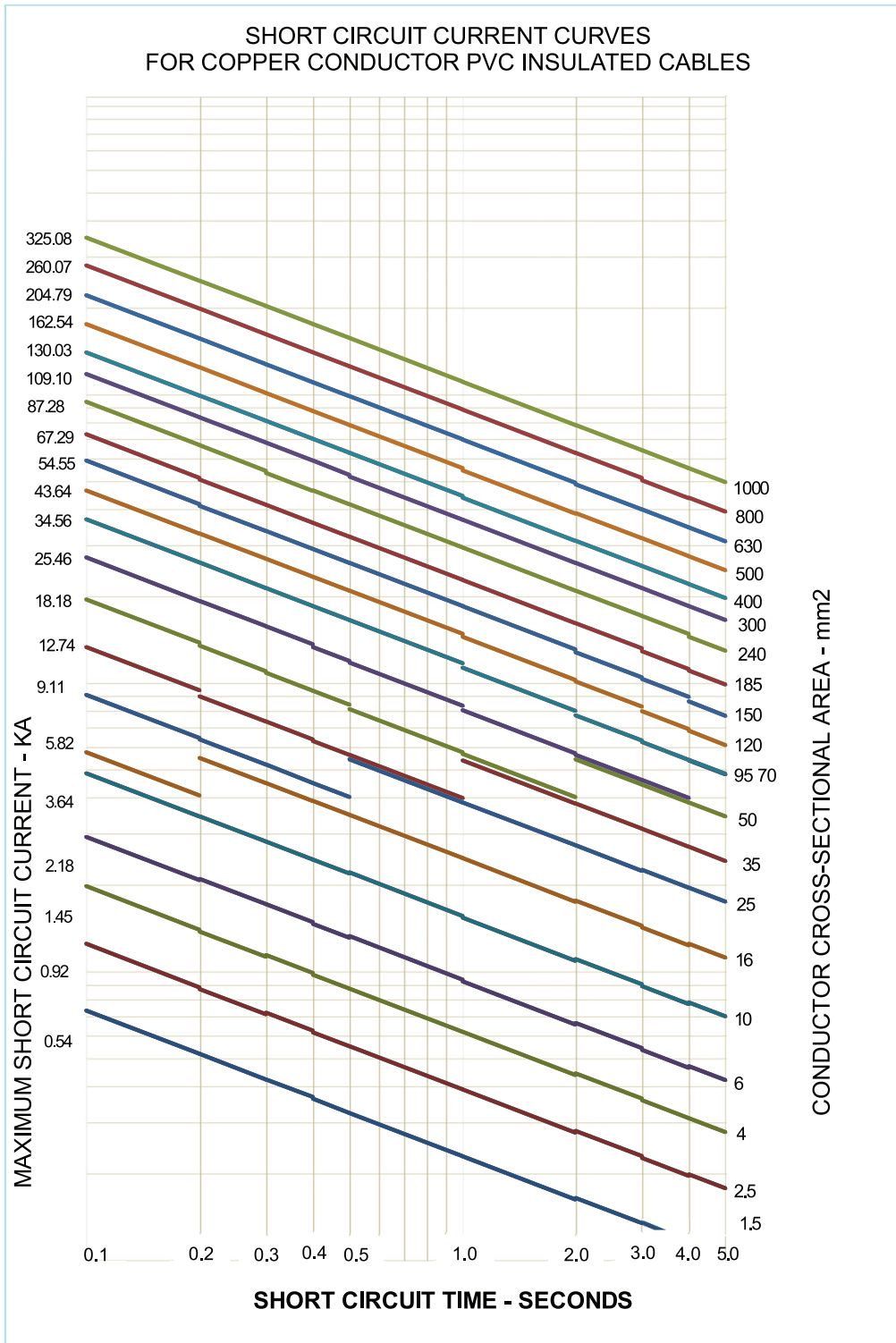

D) SHORT CIRCUIT CURRENT RATING CURVE FOR ALUMINIUM CONDUCTOR, PVC INSULATION.

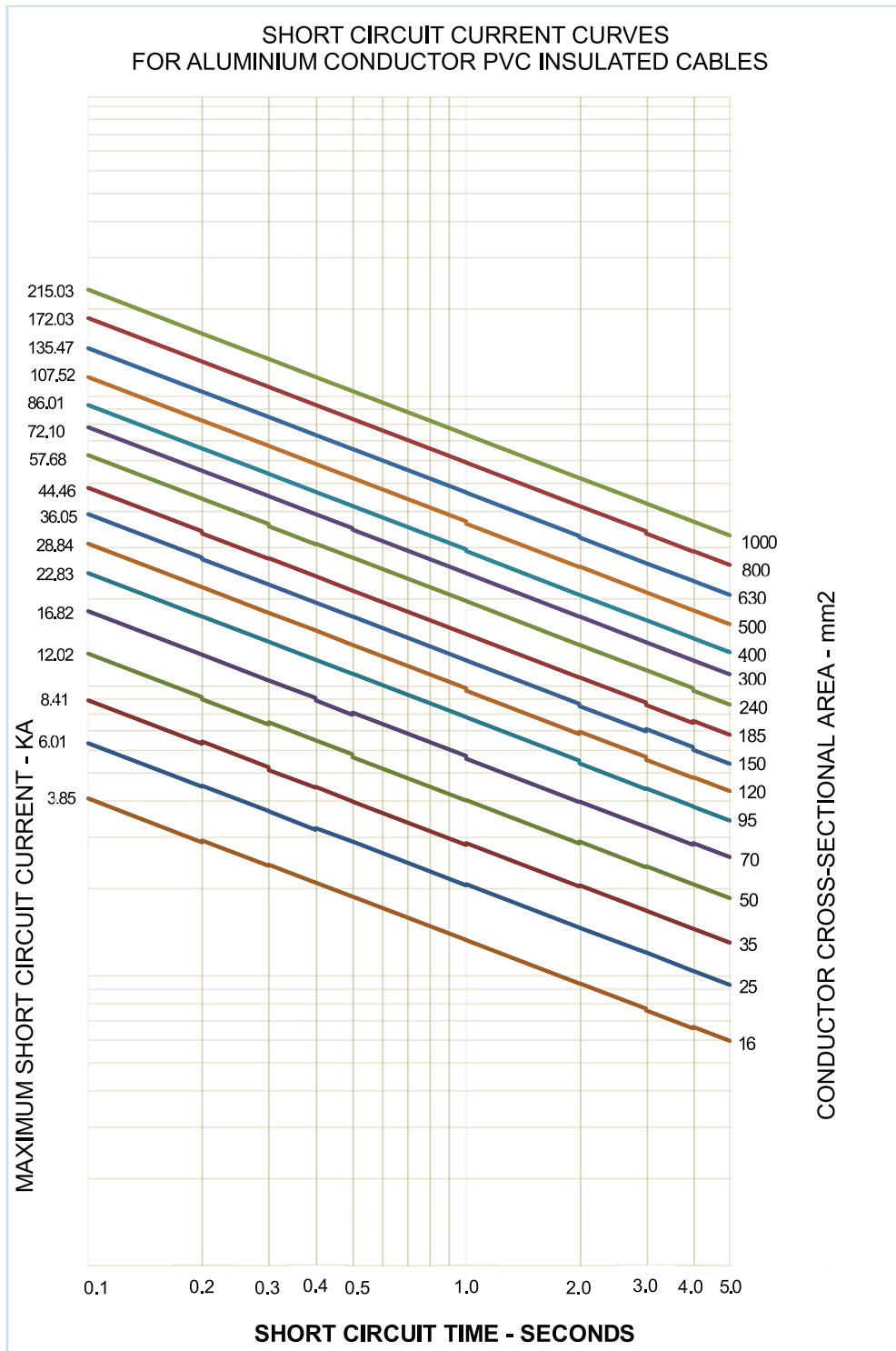

LOW VOLTAGE CABLES FOR SPECIAL APPLICATIONS

LOW VOLTAGE CABLES FOR SPECIAL APPLICATIONS

A) LV CABLES WITH WATER-BLOCKING PROPERTY

Constructional Features:

Oman Cables have the capability to manufacture low voltage cables with longitudinal water blocking properties. The longitudinal water blocking property is achieved by providing semi-conductive water blocking tapes above and below the part of the cable that needs to remain dry.

Application:

Longitudinally Water-tight cables are best suited for installation in wet locations.

Special Properties:

Longitudinal water-blocking property.

B) LV CABLES WITH FLAME RETARDANT & LOW SMOKE PROPERTY

Constructional Features:

These cables are suitable for installations in fire prone areas - where flame retardant properties and low smoke properties are essential.

Application:

These cables are suitable for installations in fire prone area where flame retardant property is must to have with low smoke property.

Special Properties:

- Oxygen index of 30 (Min.) when tested as per ASTM D 2863.
- Temperature index of 250°C (Min.) when tested as per ASTM D 2863.
- Acid gas generation max. 20% by weight as per IEC 60754-1.
- Smoke density rating 60% (Max.) as per ASTM D 2843.
- Flame retardant property as per IEC 60332-3-22 Cat A / IEC 60332-3-24 Cat C.

C) LV CABLES WITH LOW SMOKE ZERO HALOGEN PROPERTY

Constructional Features:

Oman Cables have the capability to manufacture low voltage grade cables with Low Smoke Zero Halogen (LSZH) Outer Sheath.

Application:

These cables are suitable for installations where human life is at risk due to fire and toxic smoke. For example: Oil & Gas industries, hospitals, and airports.

Special Properties:

- Oxygen index of 29 (Min.) when tested as per ASTM D 2863.
- Temperature index of 250°C (Min.) when tested as per ASTM D 2863.
- Acid gas generation max. 0.5% by weight as per IEC 60754-1.
- Min. light transmission 60%, as per IEC 61034 (Part 1 & 2).
- Flame retardant property as per IEC 60332-3-24 Cat C.

D) LV CABLES FOR VARIABLE FREQUENCY DRIVES (VFD) APPLICATIONS

Constructional Features:

i) Oman Cables have the capability to manufacture low voltage grade cables with copper tape screen.



ii) Oman Cables have the capability to manufacture low voltage grade cables with copper tape screen and interstitial bare conductor(s). The size of the interstitial conductor(s) shall be equal to half of the phase conductor. Interstitial conductor(s) can be one or three, depending upon the requirement.



Application:

These cables are suitable for industrial installations.

Special Properties:

Cables with interstitial conductors.

E) LV CABLES FOR OIL & GAS INDUSTRY

Constructional Features:

Oman Cables have the capability to manufacture Low voltage grade cables with Lead Sheath & Drylam (an alternate option to Lead Sheathed cables).

i) Drylam Cable

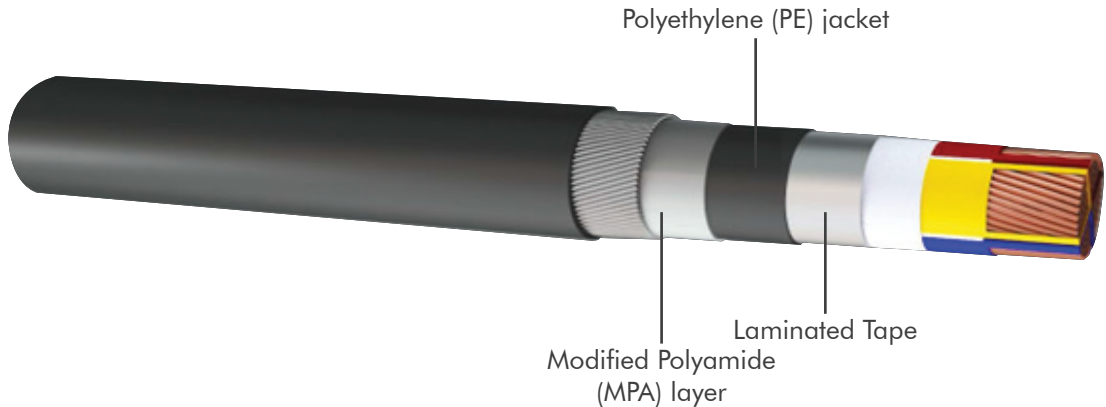

Typical constructional diagram for Multi Core Copper DRYLAM Armoured LV Cable

ii) Lead Sheathed Cable



Application:

These cables are suitable for installations in chemical or petroleum plants, or any hostile environment where protection against hydrocarbons & other chemical substances is required.

Special Properties:

- Hydrocarbons concentration immersion test.
- Chemical resistance property.
- Radial water-blocking property.
- Corrosion resistant.
- Flame retardant property as per IEC 60332-3-22 Cat A.

CABLE LAYING AND INSTALLATION GUIDELINES

CABLE LAYING AND INSTALLATION GUIDELINES

A) SELECTION OF ROUTE:

- A.1** The selection of the route should first be decided keeping in view the immediate and ultimate use of the cable as an integrated part of the transmission and distribution system.
- A.2** For a feeder run, that side of the street which presents the least obstacles and the fewest roadway crossings is naturally chosen, but if a distributor is being laid concurrently with feeders, prospects of future consumers may influence the decision on this point. In such cases, distributors should always be laid nearest to the buildings.
- A.3** For transporting the cable drums to the work site, it is necessary to check the road conditions, whether it has loose soil, is marshy, waterlogged, etc. including turns and widths. Special attention should be paid to the load bearing capacity of the bridges and culverts and other obstructions on route.
- A.4** If possible, cables should be laid along the footpath rather than the carriage way. Plans for future building projects should be considered. The route should be, as far as possible, away from parallel running gas, water pipes and telephone / telecommunication cables.
- A.5** Suitable locations for cable joints and end terminations should be selected as required.

B) MINIMUM PERMISSIBLE BENDING RADIUS:

- B.1** The cable should not be bent to a sharp radius. Minimum recommended bending radius 'R' should be maintained during installation.

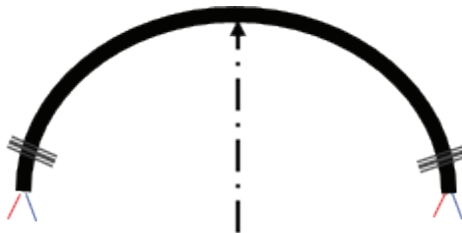

- B.2** Minimum recommended radius during installation shall be maintained as mentioned below:

Cable Type	1 Core	Multi-Core
Un-armoured Cables	8 x OD	8 x OD
Wire Armoured Cables	8 x OD	8 x OD
Tape Armoured Cables	20 x OD	15 x OD
Armoured Lead Sheathed Cables	15 x OD	15 x OD

C) MINIMUM TEMPERATURE DURING INSTALLATION

Cables shall be installed when both the cable and ambient temperatures are above 0°C and have been so for at least the previous 24 hours before installation.

D) MAXIMUM PERMISSIBLE PULLING FORCE

Maximum pulling force is the force above which cables are not recommended to get pulled. Cables are pulled with various methods e.g. Stocking, Pulling Eyes, and Winches. Maximum pulling force is calculated as mentioned below:

D.1 Cables when pulled with Stocking:

The maximum permissible pulling force when pulled with stocking, depends upon the cable type i.e. Armoured & Un-Armoured.

D.1.1. Maximum pulling force for Un-armoured cables, 'P'

$$P = 5 \times [\text{Cable OD}]^2 \text{ (mm)} \dots\dots\dots \text{Newton}$$

D.1.2. Maximum pulling force for Armoured cables, 'P'

$$P = 9 \times [\text{Cable OD}]^2 \text{ (mm)} \dots\dots\dots \text{Newton}$$

D.2 Cables when pulled by Pulling Eye:

When the cables are pulled by gripping the conductor directly with a pulling eye, the maximum permissible pulling force, depends upon the conductor material and its cross-sectional area.

D.2.1. Maximum pulling force for Copper Conductor, 'P'

$$P = 50 \text{ N/mm}^2 \times \text{Total Cross-sectional Area (mm}^2) \dots\dots\dots \text{Newton}$$

D.2.2. Maximum pulling force for Aluminium Conductor, 'P'

$$P = 30 \text{ N/mm}^2 \times \text{Total Cross-sectional Area (mm}^2) \dots\dots\dots \text{Newton}$$

E) CABLE LAYING METHODS

The conventional methods of cable laying are:

- a) Laying direct in ground.
- b) Drawing in ducts.
- c) Laying on racks in air.
- d) Laying on racks inside a cable tunnel.
- e) Laying along buildings or structures.

The best choice of any cable laying methods depends upon the actual installation conditions, initial cost of laying, cable type, maintenance and repair charges, desired ease in replacement of any cable or adding new cables etc.

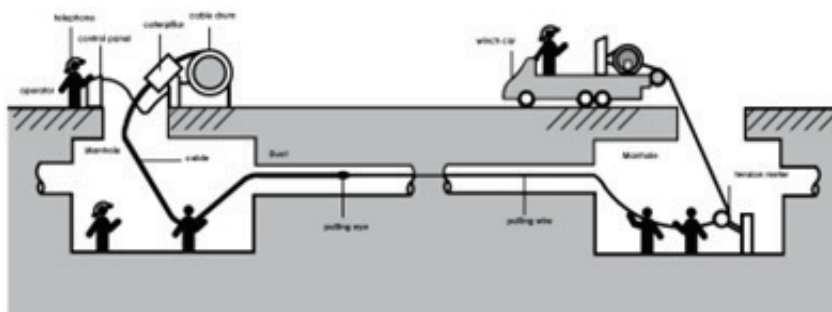
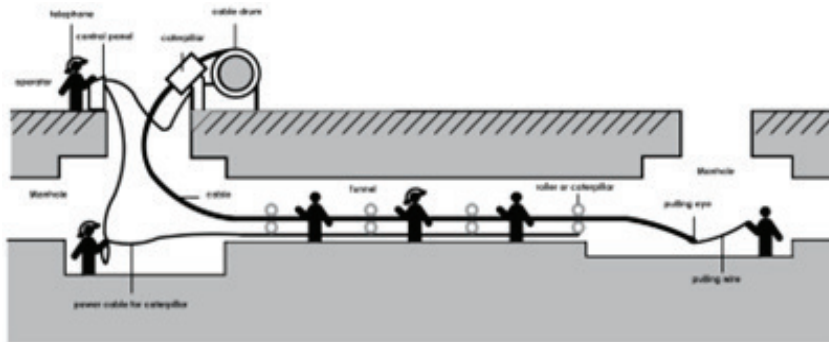
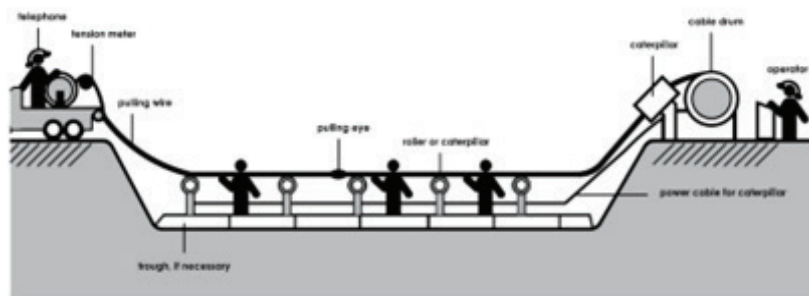

CERTIFICATES

1. System Certifications

- ISO 9001:2015 - Quality Management System
- ISO 14001:2015 - Environment Management System
- ISO 45001:2018 - Occupational Health and Safety



2. Product Certifications

- Product Certificate Requirements - BASEC
 - BS 7846 - Fire Resistance Cable Category F2
 - BS 6724
 - BS 5467
 - BS 6004
 - BS 7889
 - BS 7629-1
 - BS EN 50525-2-31 & BS EN 50525-3-41
 - BS 8592
- Fire Survival Cable Certificate - LPCB
 - 995a-OCIFLAM-FSA - Multi Core Category F2
 - 995b-OCIFLAM-FS1 - Single Core CWZ
 - 995c-OCIFLAM1 PREMIUM (PH120) & OCIFLAM2 PREMIUM(F120)
 - 995d-OCIFLAM X
 - 995e-PRYSMIAN(O) FP400
 - 995f-DRAKA(O) FTP
- Omani Quality Mark Approval for Cables
 - BS EN 50525-2-31 & BS EN 50525-3-41
 - BS 6724
 - BS 5467
 - IEC 60502-1 & 60502-2
- Emirates Quality Mark Approval for Cables
 - IEC 60502-1
 - BS 6724
 - BS 5467
 - BS EN 50525-2-31 & BS EN 50525-3-41
 - BS 7846
 - BS 7629
 - EN 50288-7
 - BS 7889



علامة الجودة الإماراتية
Emirates Quality Mark

BUILDING SUSTAINABLE GROWTH

Head Office and Factory

PO Box 25 Rusayl, Postal Code 124
Sultanate of Oman
Tel: + 968 2444 3100 Fax: + 968 2444 6096
E-mail: omancables@omancables.com
Website: www.omancables.com

Marketing

PO Box 25 Rusayl, Postal Code 124
Sultanate of Oman
Tel: + 968 2444 3100 Fax: + 968 2444 6096
E-mail: oci.marketing@omancables.com

UAE Office

PO Box 25864, Sharjah
United Arab Emirates
Tel: +971 6-5448445 Fax: +971 6 5447901
sharjah.office@omancables.com

Qatar Office

PO Box 24410, Salwa Road
Doha (Qatar)
Tel: +974 4468 8384 / + 974 4458 0482
Fax: +974 4468 7663
doha.office@omancables.com

Saudi Arabia Office

P.O. Box 26993, Riyadh 11496
Riyadh Kingdom of Saudi Arabia
Tel: +966 11 2068055 Fax: +966 11 2142730
riyadh.office@omancables.com

Egypt Office

Office No.418, The 47th Building, North 90th Street
New Cairo, Egypt
Tel: +202 2503 2986
egypt.office@omancables.com

omancables.com



Sultanate of Oman - Muscat, Plot #206, Road 2, P.O. Box: 25, Rusayl, P.C. 124
tel +968 2444 3100 | Fax +968 2444 6096

omancables.com